



SANYO Semiconductors

## DATA SHEET

# LA6588M

Monolithic Linear IC  
 24V power supply, BTL output linear drive  
 Single-phase Fan Motor IC

## Overview

The LA6588M is a Single-phase bipolar fan motor IC for 24V power supply. BTL output linear drive ensures highly-efficient, energy-saving, and silent drive while suppressing the ineffective current. Lock protection and lock signal circuit are incorporated, proving most suitable for consumer equipment power supply, OA equipment and car audio system, etc which require high reliability and low noise.

## Functions

- Single-phase full-wave linear drive by BTL output (gain resistance 500 to 360k, 57dB)  
: No switching noise, which is most favorable for use in equipment requiring silent operation, such as consumer equipment power supply, car audio system, etc.
- Operable at low voltage and over a wide operation voltage range (8 to 26.4V)
- Low saturation output (Upper + lower saturation voltages:  $V_{O\text{sat}}$  (total) = 1.1V typ,  $I_O = 200\text{mA}$ )  
: High coil efficiency and small current drain. Small heat generation from IC itself
- Lock protection and automatic return circuits incorporated
- Lock protection signal output (L during rotation, H at stop, open collector output)
- Output (Rotation detection output: Open collector output)
- Hall bias incorporated ( $V_{HB} = 1.5\text{V}$ )
- Heat protection circuit  
: The heat protection circuit suppresses the drive current to prevent burn or damage of IC when the large current flows due to output short-circuit and the IC chip temperature exceeds 180°C.
- Small package with high heat capacity (MFP10S) Pin- compatible silent series (5V/12V/24V products)

## Specifications

**Absolute Maximum Ratings** at  $T_a = 25^\circ\text{C}$

Parameter	Symbol	Conditions	Ratings	Unit
Supply voltage	$V_{CC}$ max		28	V
Output current	$I_{OUT}$ max		0.8	A
Output withstand voltage	$V_{OUT}$ max		28	V
Output withstand voltage of RD/FG output pin	$V_{RD/FG}$ max		28	V
RD/FG output current	$I_{RD/FG}$ max		5	mA
HB output current	$I_B$ max		10	mA

Continued on next page.

■ Any and all SANYO Semiconductor products described or contained herein do not have specifications that can handle applications that require extremely high levels of reliability, such as life-support systems, aircraft's control systems, or other applications whose failure can be reasonably expected to result in serious physical and/or material damage. Consult with your SANYO Semiconductor representative nearest you before using any SANYO Semiconductor products described or contained herein in such applications.

■ SANYO Semiconductor assumes no responsibility for equipment failures that result from using products at values that exceed, even momentarily, rated values (such as maximum ratings, operating condition ranges, or other parameters) listed in products specifications of any and all SANYO Semiconductor products described or contained herein.

**SANYO Semiconductor Co., Ltd.**

TOKYO OFFICE Tokyo Bldg., 1-10, 1 Chome, Ueno, Taito-ku, TOKYO, 110-8534 JAPAN

# LA6588M

Continued from preceding page.

Parameter	Symbol	Conditions	Ratings	Unit
Allowable dissipation	Pd max	Mounted on a specified board. *	800	mW
Operating temperature	T <sub>opr</sub>		-30 to +90	°C
Storage temperature	T <sub>stg</sub>		-55 to +150	°C

\* Mounted on a specified board: 114.3×76.1×1.6 mm<sup>3</sup>, glass epoxy board.

## Recommended Operating Conditions at Ta = -30 to +90°C

Parameter	Symbol	Conditions	Ratings			Unit
			min	typ	max	
Supply voltage	V <sub>CC</sub>		8		26.4	V
Common-phase input voltage range of Hall input	V <sub>ICM</sub>		0		V <sub>CC</sub> -1.5	V

## Electrical Characteristics at Ta = 25°C, V<sub>CC</sub> = 24V, unless otherwise specified.

Parameter	Symbol	Conditions	Ratings			Unit
			min	typ	max	
Circuit Current	I <sub>CC1</sub>	During drive (CT = L)	4.5	7	9.5	mA
	I <sub>CC2</sub>	During lock protection (CT = H)	2.5	4.5	6.5	mA
Lock detection capacitor charge current	I <sub>CT1</sub>		2.0	2.7	3.5	μA
Capacitor discharge current	I <sub>CT2</sub>		0.15	0.23	0.30	μA
Capacitor charge and discharge current ratio	R <sub>CT</sub>	RCD = I <sub>CT1</sub> /I <sub>CT2</sub>	10	12	14	
CT charge voltage	V <sub>CT1</sub>		1.55	1.7	1.8	V
CT discharge voltage	V <sub>CT2</sub>		0.65	0.75	0.85	V
OUT output L saturation voltage	V <sub>OL</sub>	I <sub>O</sub> = 200mA		0.2	0.3	V
OUT output H saturation voltage	V <sub>OH</sub>	I <sub>O</sub> = 200mA		0.9	1.2	V
Hall input sensitivity	V <sub>HN</sub>	Zero peak value (including offset and hysteresis)		7		mV
RD/FG output pin L voltage	V <sub>RD/FG</sub>	I <sub>RD/FG</sub> = 5mA		0.2	0.3	V
RD/FG output pin leak current	I <sub>RD/FG</sub>	V <sub>RD/FG</sub> = 15V		1	3	μA
HB output voltage	V <sub>HB</sub>	I <sub>HB</sub> = 5mA	1.3	1.5	1.7	V

## Truth Table

IN <sup>-</sup>	IN <sup>+</sup>	CT	OUT1	OUT2	FG	RD	Mode
H	L	L	H	L	L	L	During rotation
L	H		L	H	H		
-	-	H	OFF	OFF	-	H	During overheat protection

-:Don't care.

# LA6588M

## Package Dimensions

unit : mm (typ)  
3086B

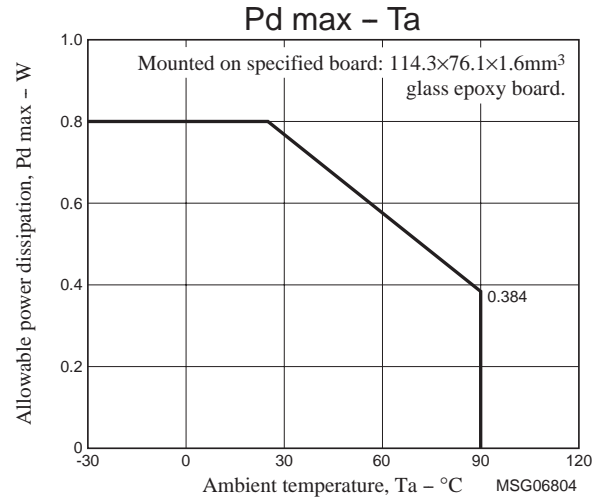
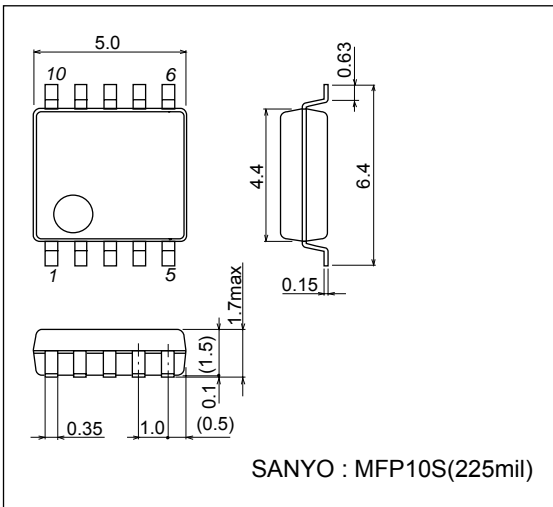

## Pin Assignment

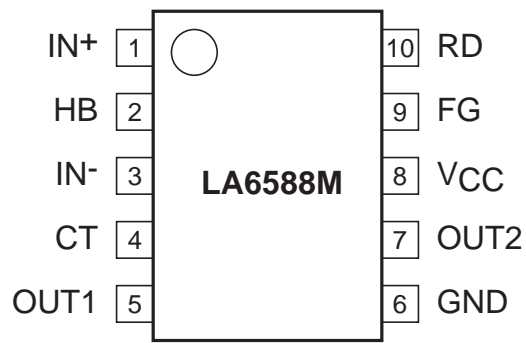

Top View

# LA6588M

## Block Diagram

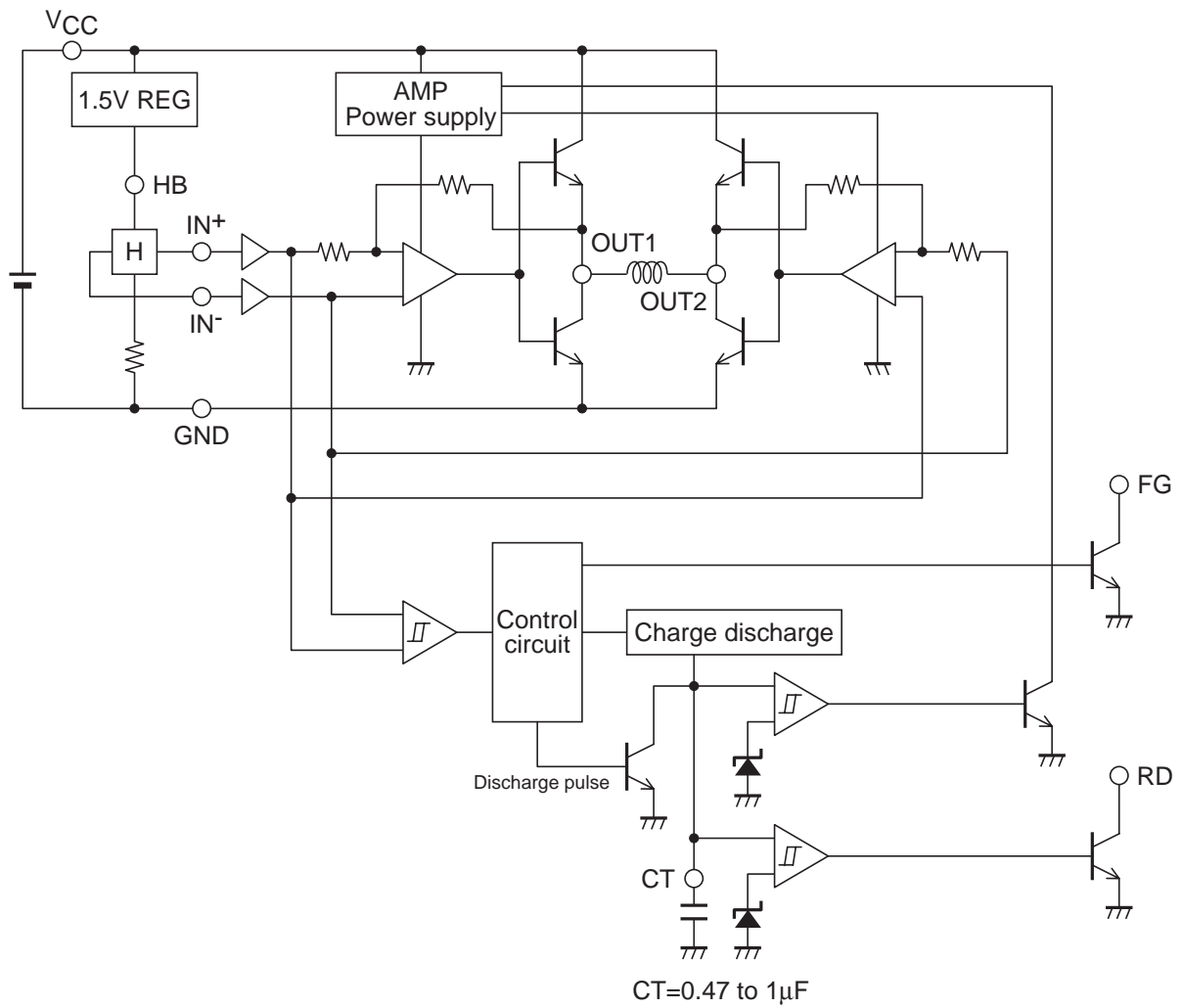

## Application Circuit Examples

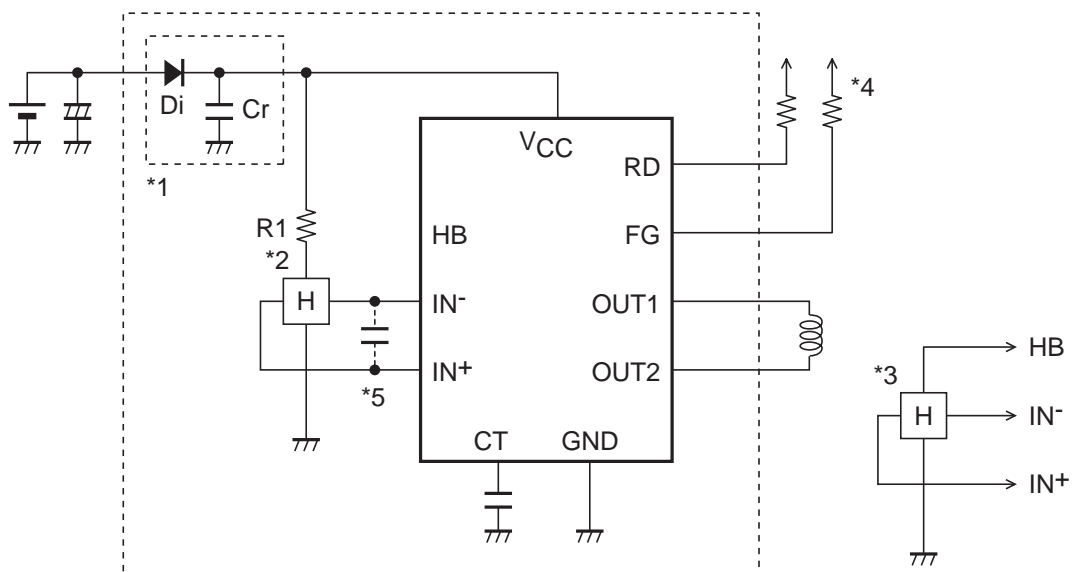

## LA6588M

---

- \*1: When Di to prevent breakdown in case of reverse connection is used, it is necessary to insert a capacitor Cr to secure the regenerative current route. Similarly, Cr is necessary to enhance the reliability when there is no capacitor near the fan power line.
- \*2: When taking Hall bias from V<sub>CC</sub>, carry out bias to V<sub>CC</sub> with resistor R1 as shown in the figure. Linear drive is achieved through voltage control of the coil by amplifying the Hall output. With large Hall element output, the start performance and efficiency are improved. Noise can be reduced further by adjusting the Hall element.
- \*3: When the Hall bias is taken from the HB pin, constant-voltage bias is made with about 1.5V. Therefore, the Hall element can provide the output satisfactory in temperature characteristics.
- \*4: Keep this open when not using.
- \*5: When the wiring from the Hall output to IC Hall input is long, noise may be carried through the wiring. In this case, insert the capacitor as shown in the figure.

- Specifications of any and all SANYO Semiconductor products described or contained herein stipulate the performance, characteristics, and functions of the described products in the independent state, and are not guarantees of the performance, characteristics, and functions of the described products as mounted in the customer's products or equipment. To verify symptoms and states that cannot be evaluated in an independent device, the customer should always evaluate and test devices mounted in the customer's products or equipment.
- SANYO Semiconductor Co., Ltd. strives to supply high-quality high-reliability products. However, any and all semiconductor products fail with some probability. It is possible that these probabilistic failures could give rise to accidents or events that could endanger human lives, that could give rise to smoke or fire, or that could cause damage to other property. When designing equipment, adopt safety measures so that these kinds of accidents or events cannot occur. Such measures include but are not limited to protective circuits and error prevention circuits for safe design, redundant design, and structural design.
- In the event that any or all SANYO Semiconductor products (including technical data, services) described or contained herein are controlled under any of applicable local export control laws and regulations, such products must not be exported without obtaining the export license from the authorities concerned in accordance with the above law.
- No part of this publication may be reproduced or transmitted in any form or by any means, electronic or mechanical, including photocopying and recording, or any information storage or retrieval system, of otherwise, without the prior written permission of SANYO Semiconductor Co., Ltd.
- Any and all information described or contained herein are subject to change without notice due to product/technology improvement, etc. When designing equipment, refer to the "Delivery Specification" for the SANYO Semiconductor product that you intend to use.
- Information (including circuit diagrams and circuit parameters) herein is for example only; it is not guaranteed for volume production. SANYO Semiconductor believes information herein is accurate and reliable, but no guarantees are made or implied regarding its use or any infringements of intellectual property rights or other rights of third parties.

This catalog provides information as of August, 2006. Specifications and information herein are subject to change without notice.