

3.3-V/5-V Input, 6-A, D-CAP+™ Mode Synchronous Step-Down Integrated FETs Converter With 2-Bit VID

Check for Samples: [TPS51461](#)

FEATURES

- Integrated FETs Converter w/TI Proprietary D-CAP+™ Mode Architecture
- 6-A Maximum Output Current
- Minimum External Parts Count
- Support all MLCC Output Capacitor and SP/POSCAP
- Auto Skip Mode
- Selectable 700-kHz and 1-MHz Frequency
- Small 4 × 4, 24-Pin, QFN Package

APPLICATIONS

- Low-Voltage Applications Stepping Down from 5-V or 3.3-V Rail
- Notebook/Desktop Computers

DESCRIPTION

The TPS51461 is a fully integrated synchronous buck regulator employing D-CAP+™. It is used for up to 5-V step-down where system size is at its premium, performance and optimized BOM are must-haves.

This device fully supports Intel system agent applications with integrated 2-bit VID function.

The TPS51461 also features two switching frequency settings (700 kHz and 1 MHz), skip mode, pre-bias startup, programmable external capacitor soft-start time/voltage transition time, output discharge, internal VBST Switch, 2-V reference ($\pm 1\%$), power good and enable.

The TPS51461 is available in a 4 mm × 4 mm, 24-pin, QFN package (Green RoHS compliant and Pb free) and is specified from 0°C to 85°C.

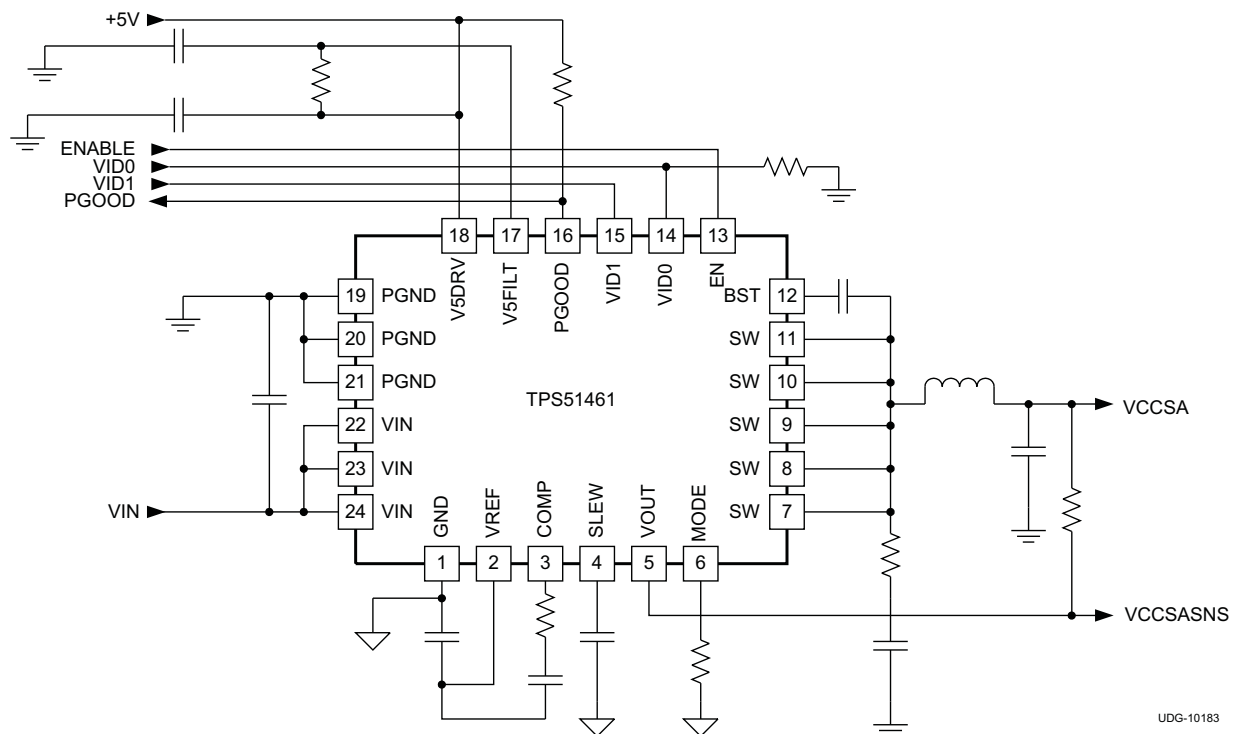

Please be aware that an important notice concerning availability, standard warranty, and use in critical applications of Texas Instruments semiconductor products and disclaimers thereto appears at the end of this data sheet.

D-CAP+ is a trademark of Texas Instruments.



These devices have limited built-in ESD protection. The leads should be shorted together or the device placed in conductive foam during storage or handling to prevent electrostatic damage to the MOS gates.

ORDERING INFORMATION⁽¹⁾

T _A	PACKAGE ⁽²⁾	ORDERING NUMBER	PINS	OUTPUT SUPPLY	MINIMUM QUANTITY	ECO PLAN
0°C to 85°C	Plastic QFN (RGE)	TPS51461RGER	24	Tape and reel	3000	Green (RoHS and no Pb/Br)
		TPS51461RGET	24	Mini reel	250	

- (1) For the most current package and ordering information, see the *Package Option Addendum* at the end of this document, or visit the TI website at www.ti.com.
 (2) Package drawings, standard packing quantities, thermal data, symbolization, and PCB design guidelines are available at www.ti.com/sc/package.

THERMAL INFORMATION

THERMAL METRIC ⁽¹⁾		TPS51461	UNITS
		RGE (24) PIN	
θ_{JA}	Junction-to-ambient thermal resistance	33.6	°C/W
θ_{JCTop}	Junction-to-case (top) thermal resistance	45.0	
θ_{JB}	Junction-to-board thermal resistance	10.8	
Ψ_{JT}	Junction-to-top characterization parameter	0.2	
Ψ_{JB}	Junction-to-board characterization parameter	10.4	
θ_{JCbott}	Junction-to-case (bottom) thermal resistance	3.8	

- (1) For more information about traditional and new thermal metrics, see the *IC Package Thermal Metrics* application report, SPRA953.

ABSOLUTE MAXIMUM RATINGS⁽¹⁾

over operating free-air temperature range (unless otherwise noted)

		VALUE		UNIT
		MIN	MAX	
Input voltage range	VIN, EN, MODE	-0.3	7.0	V
	V5DRV, V5FILT, VBST (with respect to SW)	-0.3	5.5	
	VBST	-0.3	12.5	
	VID0, VID1	-0.3	3.6	
	VOUT	-1.0	3.6	
Output voltage range	SW	-2.0	7.0	V
	SW (transient 20 ns and E=5 μ J)	-3.0		
	COMP, SLEW, VREF	-0.3	3.6	
	PGND	-0.3	0.3	
	PGOOD	-0.3	7.0	
Electrostatic Discharge	Human Body Model (HBM)		2000	V
	Charged Device Model (CDM)		500	
Storage temperature	T _{stg}	-55	150	°C
Junction temperature	T _J	0	150	°C
Lead temperature 1,6 mm (1/16 inch) from case for 10 seconds				300 °C

- (1) Stresses beyond those listed under “absolute maximum ratings” may cause permanent damage to the device. These are stress ratings only and functional operation of the device at these or any other conditions beyond those indicated under “recommended operating conditions” is not implied. Exposure to absolute-maximum-rated conditions for extended periods may affect device reliability.

RECOMMENDED OPERATING CONDITIONS

		VALUE			UNIT
		MIN	TYP	MAX	
Input voltage range	VIN, EN, MODE	-0.1		6.5	V
	V5DRV, V5FILT, VBST(with respect to SW)	-0.1		5.25	
	VBST	-0.1		11.75	
	VID0, VID1	-0.1		3.5	
	VOUT	-0.8		2.0	
Output voltage range	SW	-1.8		6.5	V
	COMP, SLEW, VREF	-0.1		3.5	
	PGOOD	-0.1		6.5	
	PGND	-0.1		0.1	
Ambient temperature range, T _A		0		85	°C

ELECTRICAL CHARACTERISTICS

over recommended free-air temperature range, $V_{VIN} = 5.0\text{ V}$, $V_{V5DRV} = V_{V5FILT} = 5\text{ V}$, $MODE = OPEN$, $PGND = GND$ (unless otherwise noted)

PARAMETER		CONDITIONS	MIN	TYP	MAX	UNIT
SUPPLY: VOLTAGE, CURRENTS AND 5 V UVLO						
I_{VINSD}	VIN shutdown current	EN = 'LO'		0.02	5	μA
V_{5VIN}	5VIN supply voltage	V5DRV and V5FILT voltage range	4.50	5.00	5.25	V
I_{5VIN}	5VIN supply current	EN = 'HI', V5DRV + V5FILT supply current		1.1	2	mA
I_{5VINSD}	5VIN shutdown current	EN = 'LO', V5DRV + V5FILT shutdown current		10	50	μA
V_{V5UVLO}	V5FILT UVLO	Ramp up; EN = 'HI'	4.2	4.3	4.5	V
$V_{V5UVHYS}$	V5FILT UVLO hysteresis	Falling hysteresis		440		mV
$V_{VREFUVLO}$	REF UVLO ⁽¹⁾	Rising edge of VREF, EN = 'HI'		1.8		V
$V_{VREFUVHYS}$	REF UVLO hysteresis ⁽¹⁾			100		mV
$V_{PORV5FILT}$	Reset	OVP latch is reset by V5FILT falling below the reset threshold	1.5	2.3	3.1	V
VOLTAGE FEEDBACK LOOP: VREF, VOUT, AND VOLTAGE GM AMPLIFIER						
V_{OUTTOL}	VOUT accuracy	$V_{VOUT} = 0.8\text{V}$, No droop	-1.5%	0%	1.5%	
V_{VREF}	VREF	$I_{VREF} = 0\text{ }\mu\text{A}$, $T_A = 25^\circ\text{C}$		2.01		V
$I_{VREFSNK}$	VREF sink current	VREF within tolerance, $V_{VREF} = 2.05\text{ V}$		2.5		mA
G_M	Transconductance			1		mS
V_{DM}	Differential mode input voltage		0		80	mV
$I_{COMPSRC}$	COMP pin maximum sourcing current	$V_{COMP} = 2\text{ V}$		-80		μA
V_{OFFSET}	Input offset voltage	$T_A = 25^\circ\text{C}$	-3	0	3	mV
R_{DSCH}	Output voltage discharge resistance			42		Ω
f_{-3dBVL}	-3dB Frequency ⁽¹⁾			6		MHz
CURRENT SENSE: CURRENT SENSE AMPLIFIER, OVER CURRENT AND ZERO CROSSING						
A_{CSINT}	Internal current sense gain	Gain from the current of the low-side FET to PWM comparator when PWM = "OFF"	48	53	57	mV/A
I_{OCL}	Positive overcurrent limit (valley)		6	7.5		A
$I_{OCL(neg)}$	Negative overcurrent limit (valley)			-6.5	-5.0	A
V_{ZXOFF}	Zero crossing comp internal offset			0		mV
DRIVERS: BOOT STRAP SWITCH						
$R_{DSONBST}$	Internal BST switch on-resistance	$I_{VBST} = 10\text{ mA}$, $T_A = 25^\circ\text{C}$		5	10	Ω
I_{BSTLK}	Internal BST switch leakage current	$V_{VBST} = 14\text{ V}$, $V_{SW} = 7\text{ V}$, $T_A = 25^\circ\text{C}$			1	μA

(1) Ensured by design, not production tested.

ELECTRICAL CHARACTERISTICS (continued)

over recommended free-air temperature range, $V_{VIN} = 5.0\text{ V}$, $V_{V5DRV} = V_{V5FILT} = 5\text{ V}$, $MODE = OPEN$, $PGND = GND$ (unless otherwise noted)

PARAMETER		CONDITIONS	MIN	TYP	MAX	UNIT
PROTECTION: OVP, UVP, PGOOD, and THERMAL SHUTDOWN						
V_{PGDLL}	PGOOD deassert to lower (PGOOD → Low)	Measured at the VOUT pin w/r/t V_{SLEW}	82%	84%	86%	
$V_{PGHYSHL}$	PGOOD high hysteresis			8%		
V_{PGDLH}	PGOOD de-assert to higher (PGOOD → Low)	Measured at the VOUT pin w/r/t V_{SLEW}	114%	116%	118%	
$V_{PGHYSHH}$	PGOOD high hysteresis			-8%		
$V_{INMINPG}$	Minimum VIN voltage for valid PGOOD	Measured at the VIN pin with a 2-mA sink current on PGOOD pin	1.0	1.3	1.5	V
V_{OVP}	OVP threshold	Measured at the VOUT pin w/r/t V_{SLEW}	118%	120%	122%	
V_{UVP}	UVP threshold	Measured at the VOUT pin w/r/t V_{SLEW} , device latches OFF, begins soft-stop	66%	68%	70%	
TH_{SD}	Thermal shutdown ⁽²⁾	Latch off controller, attempt soft-stop.		130		°C
$TH_{SD(hys)}$	Thermal Shutdown hysteresis ⁽²⁾	Controller re-starts after temperature has dropped		10		°C
TIMERS: ON-TIME, MINIMUM OFF TIME, SS, AND I/O TIMINGS						
$t_{ONESHOTC}$	PWM one-shot ⁽²⁾	$V_{VIN} = 5\text{ V}$, $V_{VOUT} = 0.8\text{ V}$, $f_{SW} = 667\text{ kHz}$, fixed VID mode		240		ns
		$V_{VIN} = 5\text{ V}$, $V_{VOUT} = 0.8\text{ V}$, $f_{SW} = 1\text{ MHz}$, fixed VID mode		160		ns
$t_{MIN(off)}$	Minimum OFF time	$V_{VIN} = 5\text{ V}$, $V_{VOUT} = 0.8\text{ V}$, $f_{SW} = 1\text{ MHz}$, DRVL on, SW = PGND, $V_{VOUT} < V_{SLEW}$		357		ns
t_{PGDDL}	PGOOD startup delay time (excl. SLEW ramp up time)	Delay starts from VOUT = VID code 00 and excludes SLEW ramp up time		3		ms
$t_{PGDPDLYH}$	PGOOD high propagation delay time	50 mV over drive, rising edge	0.8	1	1.2	ms
$t_{PGDPDLYL}$	PGOOD low propagation delay time	50 mV over drive, falling edge		10		µs
t_{OVDPDY}	OVP delay time	Time from the VOUT pin out of +20% of V_{SLEW} to OVP fault		0.2		µs
$t_{UVDPDYEN}$	Undervoltage fault enable delay (excl. SLEW ramp up time)	Time from (VOUT = VID code 00) going high to undervoltage fault is ready		3		ms
t_{UVPDLY}	UVP delay time	Time from the VOUT pin out of -30% of V_{SLEW} to UVP fault		8.5		µs
I_{SLEW}	Soft-start and voltage transition	$C_{SS} = 10\text{ nF}$ assuming voltage slew rate of 1 mV/µs	9	10	11	µA
LOGIC PINS: I/O VOLTAGE AND CURRENT						
V_{PGDPD}	PGOOD pull down voltage	PGOOD low impedance, $I_{SINK} = 4\text{ mA}$, $V_{VIN} = V_{V5FILT} = 4.5\text{ V}$			0.3	V
I_{PGDLKG}	PGOOD leakage current	PGOOD high impedance, forced to 5.5 V	-1	0	1	µA
V_{ENH}	EN logic high	EN, VCCP logic	0.8			V
V_{ENL}	EN logic low	EN, VCCP logic			0.3	V
I_{EN}	EN input current				1	µA
V_{VIDH}	VID logic high	VID0, VID1	0.8			V
V_{VIDL}	VID logic low	VID0, VID1			0.3	V
I_{VID}	VID input current				1	µA
V_{MODETH}	MODE threshold voltage ⁽³⁾	MODE 1	0.08	0.13	0.18	V
		MODE 3	0.37	0.42	0.47	
		MODE 4	0.55	0.60	0.65	
		MODE 5	0.83	0.88	0.93	
		MODE 7	1.75	1.80	1.85	
I_{MODE}	MODE current			15		µA
R_{PD}	VID pull-down resistance			10		kΩ

(2) Ensured by design, not production tested.

(3) See [Table 3](#) for descriptions of MODE parameters.

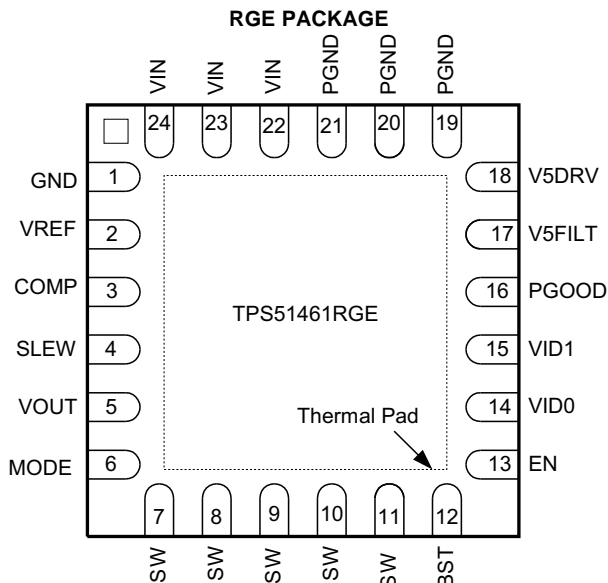

PIN FUNCTIONS

PIN		I/O	DESCRIPTION
NO.	NAME		
19	PGND	I	Power ground. Source terminal of the rectifying low-side power FET. Positive input for current sensing.
20			
21			
22	VIN	I	Power supply input pin. Drain terminal of the switching high-side power FET.
23			
24			
1	GND	–	Signal ground.
2	VREF	O	2.0-V reference output. Connect a 0.22- μ F ceramic capacitor to GND.
3	COMP	O	Connect series R/C or R between this pin and VREF for loop compensation.
4	SLEW	I/O	Program the startup and voltage transition time using an external capacitor via 10- μ A current source.
5	VOUT	I	Output voltage monitor input pin.
6	MODE	I	Allows selection of switching frequencies and output voltage. (See Table 3)
7	SW	I/O	Switching node output. Connect to the external inductor. Also serve as current-sensing negative input.
8			
9			
10			
11			
12	BST	I	Power supply for internal high-side gate driver. Connect a 0.1- μ F bootstrap capacitor between this pin and the SW pin.
13	EN	I	Enable of the SMPS.
14	VID0	I	2-bit VID input.
15	VID1		
16	PGOOD	O	Power good output. Connect pull-up resistor.
17	V5FILT	I	5-V power supply for analog circuits.
18	V5DRV	I	5-V power supply for the gate driver.

BLOCK DIAGRAM

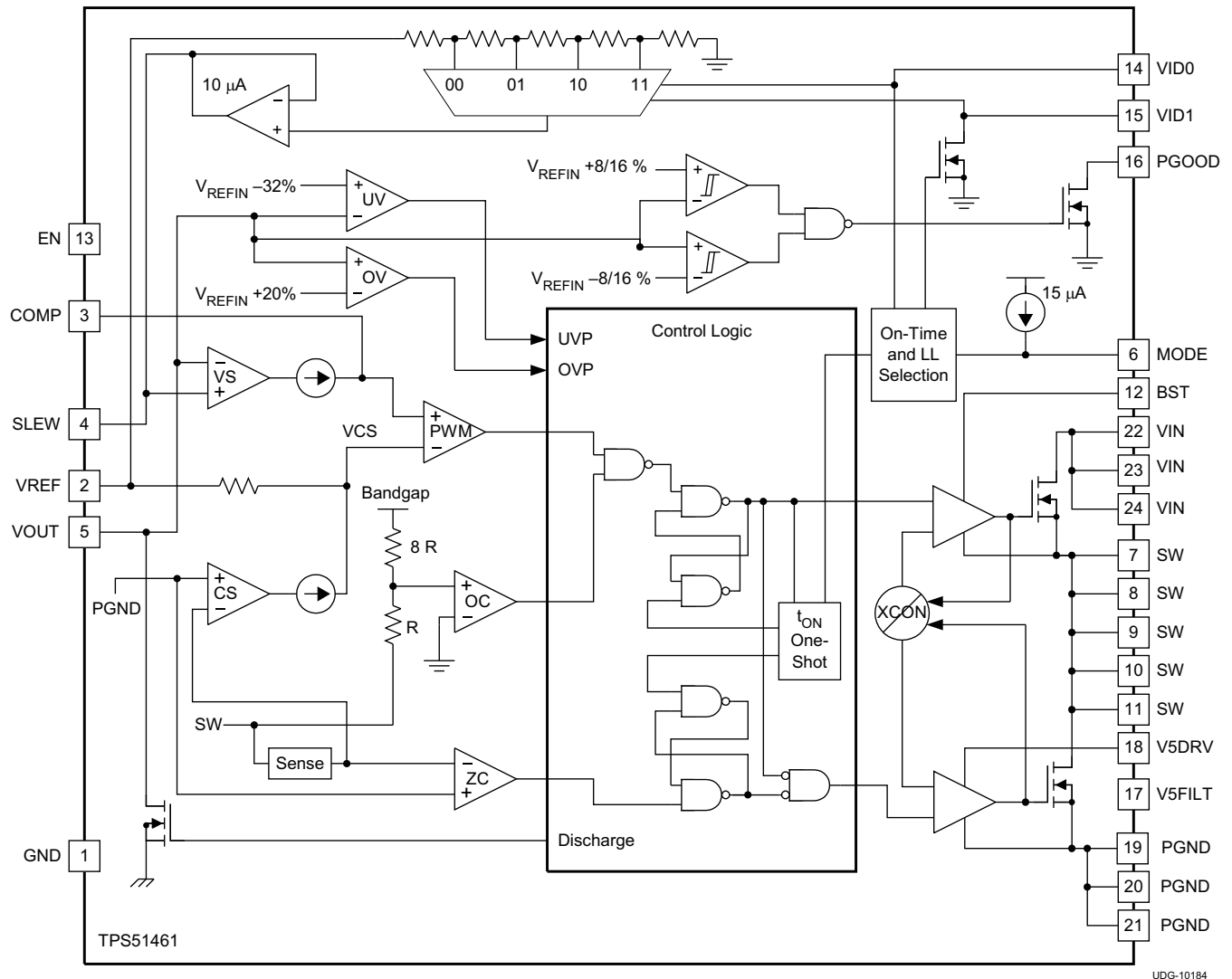
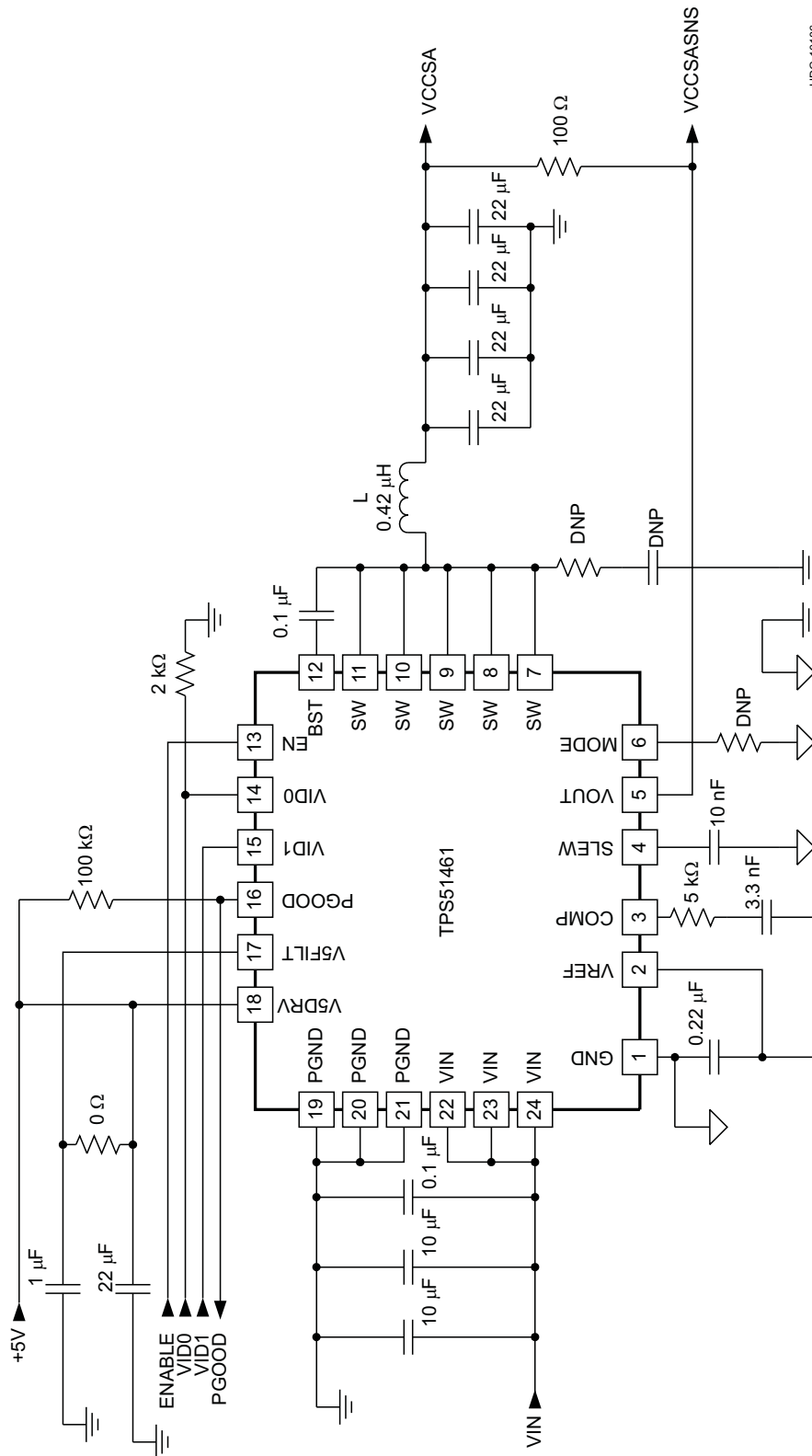

Table 1. Intel SA VID

VID 0	VID 1	VCCSA
0	0	0.9 V
0	1	0.80V ⁽¹⁾ MODE = Open
0	1	0.85V ⁽¹⁾ MODE = 33 kΩ
1	0	0.725 V
1	1	0.675 V

(1) 0.80V for 2011 SV processor and 0.85V for 2011 LV/ULV processor

APPLICATION SCHEMATIC WITH TPS51461



UDG-10186

Figure 1. Application Schematic Using Non-Droop Configuration, and Recommended Reference Design for Intel SA Application

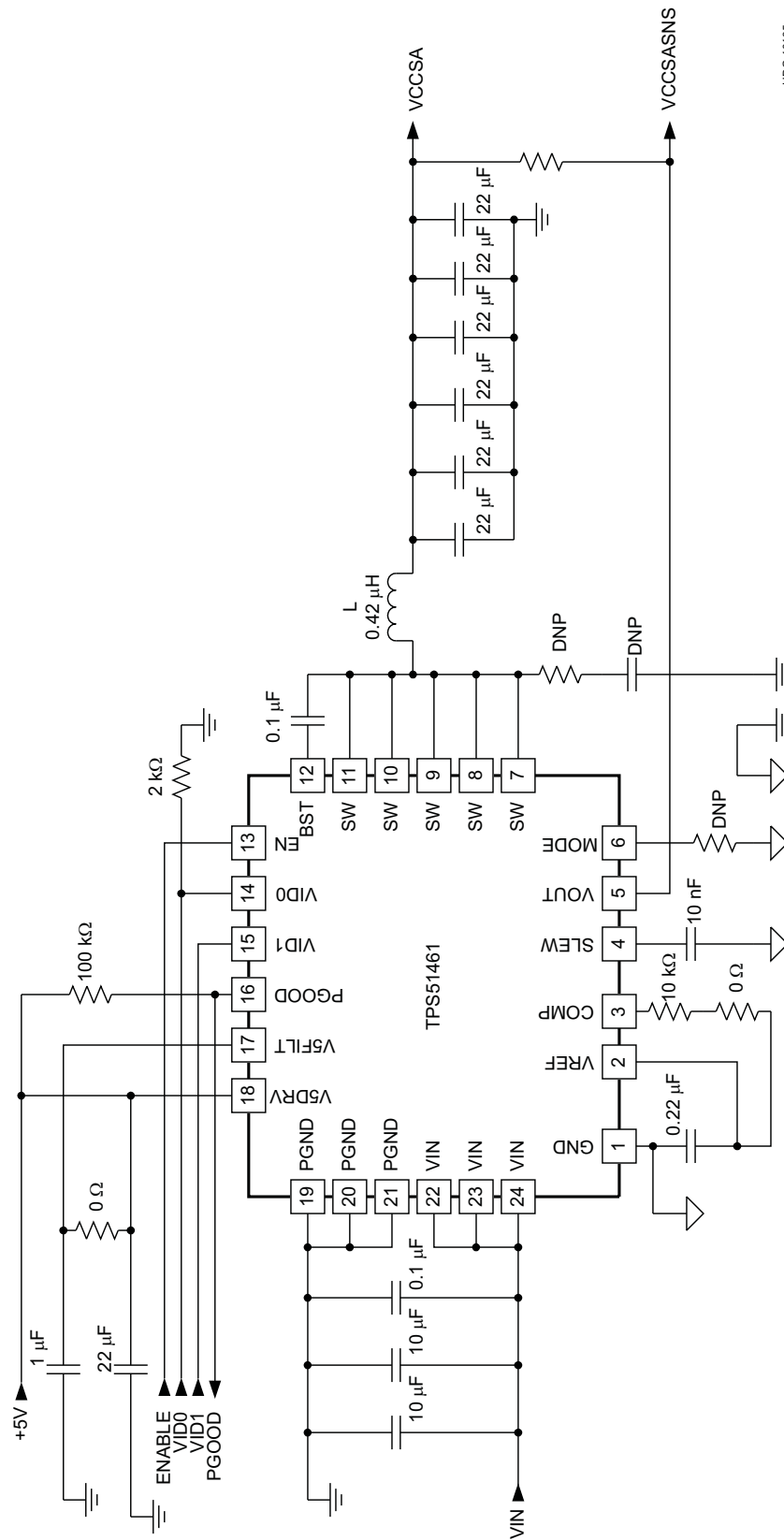

UDG-10185

Figure 2. Application Schematic Using Droop Configuration

Application Circuit List of Materials

Recommended parts for key external components for the circuits in [Figure 1](#) and [Figure 2](#) are listed in [Table 2](#).

**Table 2. Key External Component Recommendations
([Figure 1](#) and [Figure 2](#))**

FUNCTION	MANUFACTURER	PART NUMBER
Output Inductor	Nec-Tokin	MPCG0740LR42C
Ceramic Output Capacitors	Panasonic	ECJ2FB0J226M
	Murata	GRM21BR60J226ME39L

APPLICATION INFORMATION

Functional Overview

The TPS51461 is a D-CAP+™ mode adaptive on-time converter. The output voltage is set using a 2-bit DAC that outputs a reference voltage in accordance with the code defined in [Table 1](#). *VID-on-the-fly* transitions are supported with the slew rate controlled by a single capacitor on the SLEW pin. Integrated high-side and low-side FET supports output current to a maximum of 6-ADC. The converter automatically runs in discontinuous conduction mode (DCM) to optimize light-load efficiency. Two switching frequency selections are provided, (700 kHz and 1 MHz) to enable optimization of the power chain for the cost, size and efficiency requirements of the design.

In adaptive on-time converters, the controller varies the on-time as a function of input and output voltage to maintain a nearly constant frequency during steady-state conditions. In conventional constant on-time converters, each cycle begins when the output voltage crosses to a fixed reference level. However, in the TPS51461, the cycle begins when the current feedback reaches an error voltage level which is the amplified difference between the reference voltage and the feedback voltage.

PWM Operation

Referring to [Figure 3](#), in steady state, continuous conduction mode, the converter operates in the following way.

Starting with the condition that the top FET is off and the bottom FET is on, the current feedback (V_{CS}) is higher than the error amplifier output (V_{COMP}). V_{CS} falls until it hits V_{COMP} , which contains a component of the output ripple voltage. V_{CS} is not directly accessible by measuring signals on pins of TPS51461. The PWM comparator senses where the two waveforms cross and triggers the on-time generator.

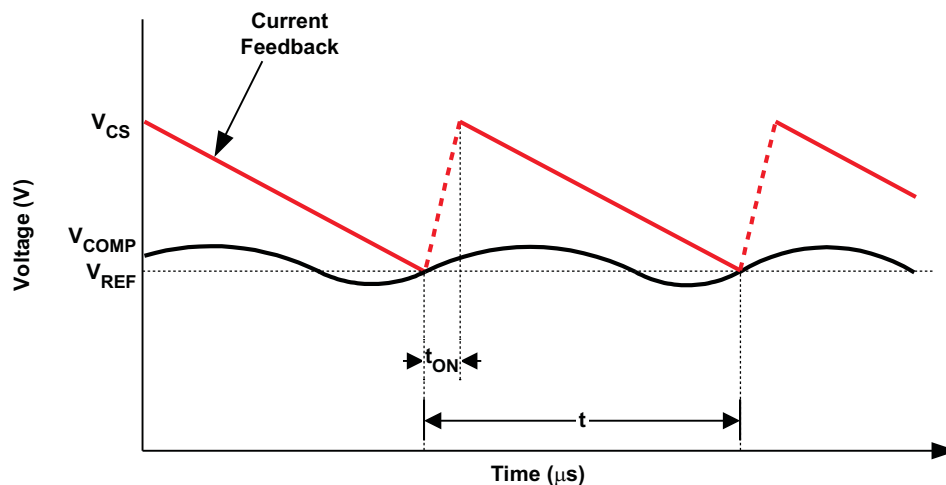

UDG-10187

Figure 3. D-CAP+™ Mode Basic Waveforms

The current feedback is an amplified and filtered version of the voltage between PGND and SW during low-side FET on-time. The TPS51461 also provides a single-ended differential voltage (V_{OUT}) feedback to increase the system accuracy and reduce the dependence of circuit performance on layout.

PWM Frequency and Adaptive on Time Control

In general, the on-time (at the SW node) can be estimated by [Equation 1](#).

$$t_{ON} = \frac{V_{OUT}}{V_{IN}} \times \frac{1}{f_{SW}}$$

where

- f_{SW} is the frequency selected by the connection of the MODE pin (1)

The on-time pulse is sent to the top FET. The inductor current and the current feedback rises to peak value. Each ON pulse is latched to prevent double pulsing. Switching frequency settings are shown in [Table 3](#).

Non-Droop Configuration

The TPS51461 can be configured as a non-droop solution. The benefit of a non-droop approach is that load regulation is flat, therefore, in a system where tight DC tolerance is desired, the non-droop approach is recommended. For the Intel system agent application, non-droop is recommended as the standard configuration.

The non-droop approach can be implemented by connecting a resistor and a capacitor between the COMP and the VREF pins. The purpose of the type II compensation is to obtain high DC feedback gain while minimizing the phase delay at unity gain cross over frequency of the converter.

The value of the resistor (R_C) can be calculated using the desired unity gain bandwidth of the converter, and the value of the capacitor (C_C) can be calculated by knowing where the zero location is desired. An application tool that calculates these values is available from your local TI Field Application Engineer.

[Figure 4](#) shows the basic implementation of the non-droop mode using the TPS51461.

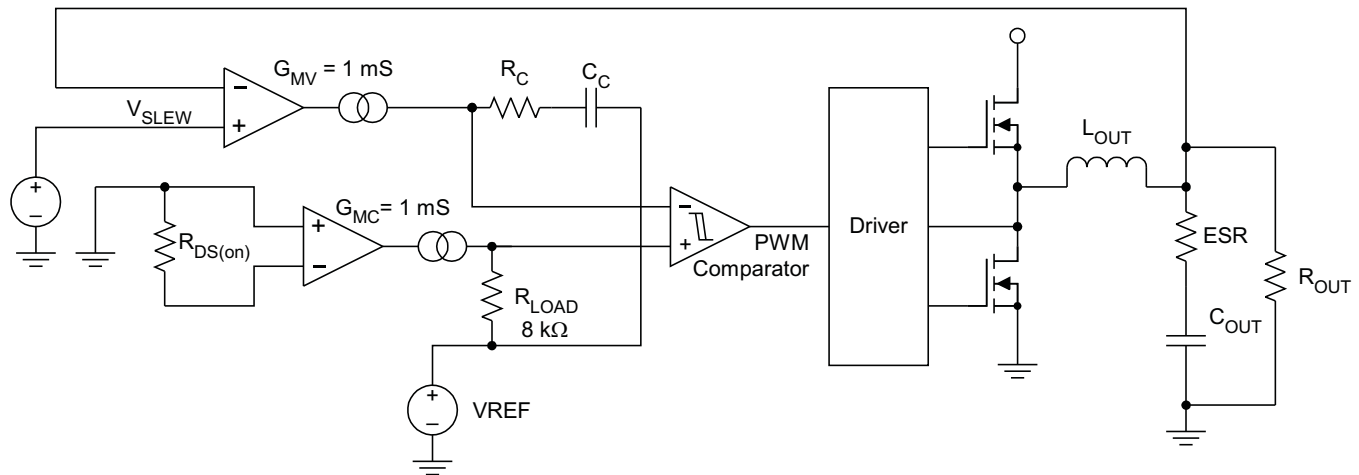

UDG-10190

Figure 4. Non-Droop Mode Basic Implementation

[Figure 5](#) shows the load regulation of the system agent rail using non-droop configuration.

[Figure 6](#) shows the transient response of TPS51461 using non-droop configuration where $C_{OUT} = 4 \times 22 \mu\text{F}$. The applied step load is from 0 A to 2 A.

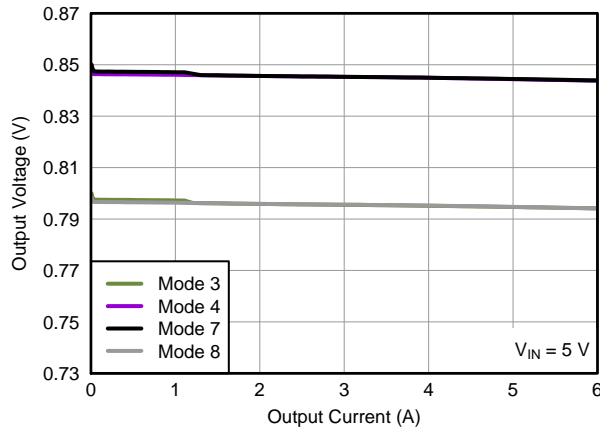

Figure 5. 0.8-V Load Regulation ($V_{IN} = 5\text{ V}$) Non-Droop Configuration

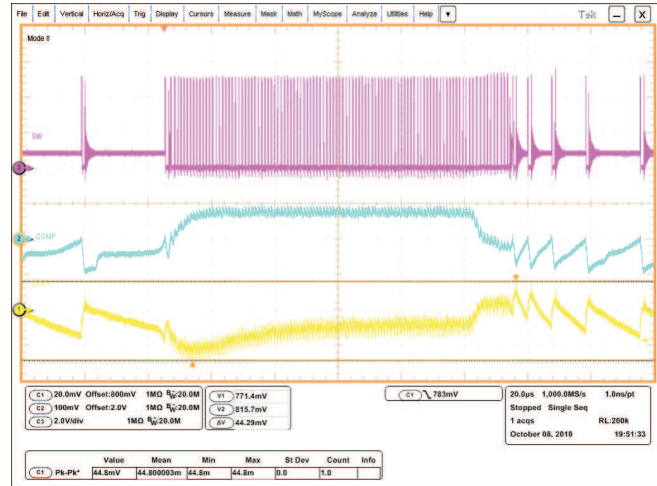

Figure 6. Non-Droop Configuration Transient Response

Droop Configuration

The terminology for droop is the same as *load line* or *voltage positioning* as defined in the Intel CPU V_{CORE} specification. Based on the actual tolerance requirement of the application, load-line set points can be defined to maximize either cost savings (by reducing output capacitors) or power reduction benefits.

Accurate droop voltage response is provided by the finite gain of the droop amplifier. The equation for droop voltage is shown in Equation 2.

$$V_{DROOP} = \frac{A_{CSINT} \times I(L)}{R_{DROOP} \times G_M}$$

where

- low-side on-resistance is used as the current sensing element
- A_{CSINT} is a constant, which nominally is 53 mV/A.
- $I(L)$ is the DC current of the inductor, or the load current
- R_{DROOP} is the value of resistor from the COMP pin to the VREF pin
- G_M is the transconductance of the droop amplifier with nominal value of 1 mS

$$R_{LOAD_LINE} = \frac{V_{DROOP}}{I(L)} = \frac{A_{CSINT}}{R_{DROOP} \times G_M} \therefore R_{DROOP} = \frac{A_{CSINT}}{R_{LOAD_LINE} \times G_M}$$

Therefore, if a 5-m Ω load line to the system agent rail is desired, the calculated R_{DROOP} is approximately 10 k Ω . Equation 2 can be used to easily derive R_{DROOP} for any load line slope/droop design target.

Figure 7 shows the basic implementation of the droop mode using the TPS51461.

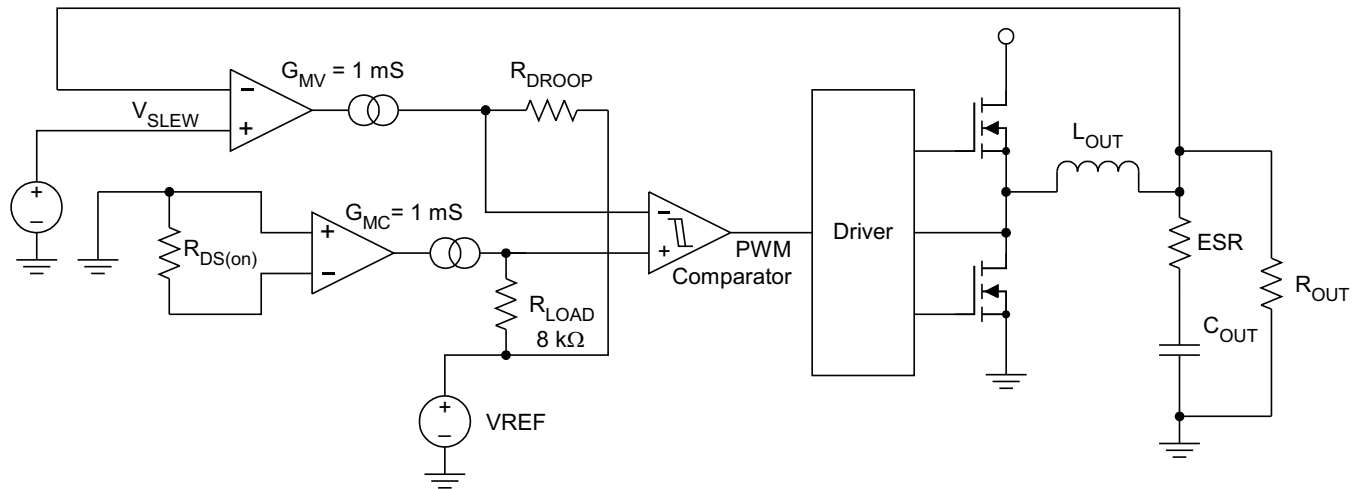

UDG-10188

Figure 7. DROOP Mode Basic Implementation

The droop (voltage positioning) method was originally recommended to reduce the number of external output capacitors required. The effective transient voltage range is increased because of the active voltage positioning (see Figure 8).

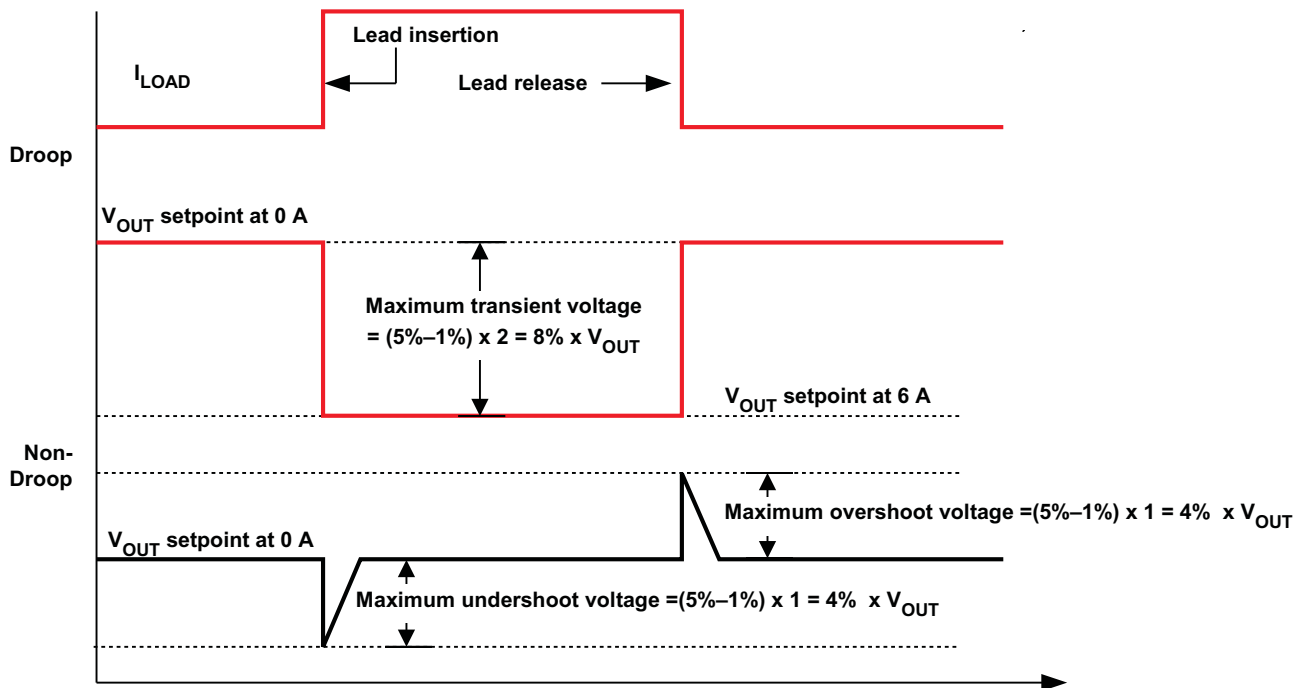

UDG-10189

Figure 8. DROOP vs Non-DROOP in Transient Voltage Window

Consider an example of 0.8 V ±5%. If no droop is permitted, the allowable transient overshoot can be at a maximum of +4%; the allowed transient undershoot can only be at minimum of -4% (given a dc tolerance of ±1%). Therefore, the overshoot and undershoot window is only ±32 mV. If the droop method is applied, this overshoot and undershoot window could be potentially doubled from ±32 mV to ±64 mV, given the same load step and release.

In applications where the DC and the AC tolerances are not separated, which means there is not a strict DC tolerance requirement, the droop method can be used.

Table 3. Mode Parameter Table

MODE	MODE CONNECTION	COMPENSATION TECHNOLOGY		VREF (V)	SWITCHING FREQUENCY (f _{sw})	VID1 = 1 VID0 = 0 (V)
		DROOP	NON-DROOP			
1	GND	X		2.05	1 MHz	0.80
3	22 kΩ	X	X	2.00	700 kHz	0.80
4	33 kΩ	X	X	2.00	1 MHz	0.85
5	47 kΩ	X		2.05	1 MHz	0.85
7	100 kΩ	X	X	2.00	700 kHz	0.85
8	Open	X	X	2.00	1 MHz	0.80

Figure 9 shows the load regulation of the 0.8-V rail using an R_{DROOP} value of 10 kΩ.

Figure 10 shows the transient response of the TPS51461 using droop configuration and C_{OUT} = 4 × 22 μF. The applied step load is from 0 A to 2 A.

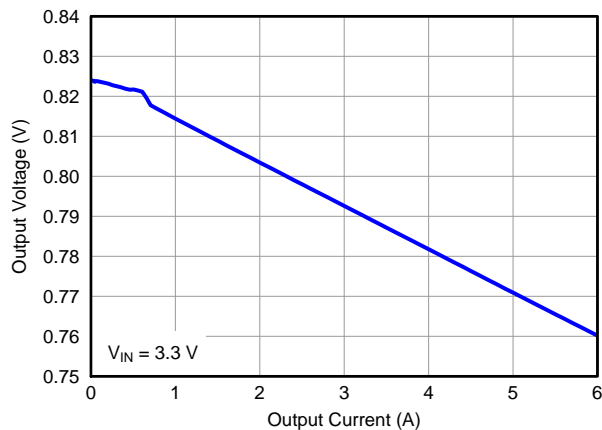

Figure 9. 0.8-V Load Regulation (V_{IN} = 3.3 V)

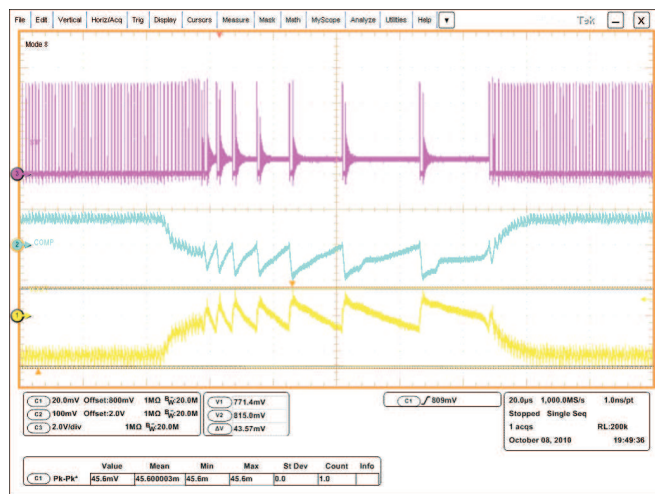

Figure 10. Droop Configuration Transient Response

Light Load Power Saving Features

The TPS51461 has an automatic pulse-skipping mode to provide excellent efficiency over a wide load range. The converter senses inductor current and prevents negative flow by shutting off the low-side gate driver. This saves power by eliminating re-circulation of the inductor current. Further, when the bottom FET shuts off, the converter enters discontinuous mode, and the switching frequency decreases, thus reducing switching losses as well.

Voltage Slewing

The TPS51461 ramps the SLEW voltage up and down to perform the output voltage transitioning. The timing is independent of switching frequency, as well as output resistive and capacitive loading. It is set by a capacitor from SLEW pin to GND, called C_{SLEW} , together with an internal current source of 10 μ A. The slew rate is used to set the startup and voltage transition rate.

$$C_{SLEW} = \frac{I_{SLEW}}{SR} \quad (4)$$

$$t_{SS} = \frac{C_{SLEW} \times 0.9V}{I_{SLEW}}$$

where

- $I_{SLEW} = 10 \mu\text{A}$ (nom)
- SR is the target output voltage slew rate, per Intel specification between 0.5 mV/ μ s and 10 mV/ μ s (5)

For the current reference design, an SR of 1 mV/ μ s is targeted. The C_{SLEW} is calculated to be 10 nF. The slower slew rate is desired to minimize large inductor current perturbation during startup and voltage transitioning thus reducing the possibility of acoustic noise.

After the power up, when VID1 is transitioning from 0 to 1, TPS51461 follows the SLEW voltage entering the forced PWM mode to actively discharge the output voltage from 0.9 V to 0.8 V. The actual output voltage slew rate is approximately the same as the set slew rate while the bandwidth of the converter supports it and there is no overcurrent triggered by additional charging current flowing into the output capacitors. After SLEW transition is completed, PWM mode is maintained for 64 μ s (16 clock cycles when the frequency is 1 MHz) to ensure voltage regulation.

Protection Features

The TPS51461 offers many features to protect the converter power chain as well as the system electronics.

5-V Undervoltage Protection (UVLO)

The TPS51461 continuously monitors the voltage on the V5FILT pin to ensure that the voltage level is high enough to bias the device properly and to provide sufficient gate drive potential to maintain high efficiency. The converter starts with approximately 4.3 V and has a nominal of 440 mV of hysteresis. If the 5-V UVLO limit is reached, the converter transitions the phase node into a 3-state function. And the converter remains in the off state until the device is reset by cycling 5 V until the 5-V POR is reached (2.3-V nominal). The power input does not have an UVLO function

Power Good Signals

The TPS51461 has one open-drain *power good* (PGOOD) pin. During startup, there is a 3 ms power good delay starting from the output voltage reaching the regulation point (excluding soft-start ramp-up time). And there is also a 1 ms power good high propagation delay. The PGOOD pin de-asserts as soon as the EN pin is pulled low or an undervoltage condition on V5FILT is detected. The PGOOD signal is blanked during VID voltage transitions to prevent false triggering during voltage slewing.

Output Overvoltage Protection (OVP)

In addition to the power good function described above, the TPS51461 has additional OVP and UVP thresholds and protection circuits.

An OVP condition is detected when the output voltage is approximately $120\% \times V_{SLEW}$. In this case, the converter de-asserts the PGOOD signals and performs the overvoltage protection function. The converter remains in this state until the device is reset by cycling 5 V until the 5-V POR threshold (2.3 V nominal) is reached.

Output Undervoltage Protection (UVP)

Output undervoltage protection works in conjunction with the current protection described in the [Overcurrent Protection](#) and [Overcurrent Limit](#) sections. If the output voltage drops below 70% of V_{SLEW} , after an 8- μ s delay, the device latches OFF. Undervoltage protection can be reset only by EN or a 5-V POR.

Overcurrent Protection

Both positive and negative overcurrent protection are provided in the TPS51461:

- Overcurrent Limit (OCL)
- Negative OCL (level same as positive OCL)

Overcurrent Limit

If the sensed current value is above the OCL setting, the converter delays the next ON pulse until the current drops below the OCL limit. Current limiting occurs on a pulse-by-pulse basis. The TPS51461 uses a valley current limiting scheme where the DC OCL trip point is the OCL limit plus half of the inductor ripple current. The minimum valley OCL is 6 A over process and temperature.

During the overcurrent protection event, the output voltage likely droops until the UVP limit is reached. Then, the converter de-asserts the PGOOD pin, and then latches OFF after an 8- μ s delay. The converter remains in this state until the device is reset by EN or a 5VFILT POR.

$$I_{OCL(dc)} = I_{OCL(valley)} + \frac{1}{2} \times I_{P-P} \quad (6)$$

Negative OCL

The negative OCL circuit acts when the converter is sinking current from the output capacitor(s). The converter continues to act in a *valley* mode, the absolute value of the negative OCL set point is typically -6.5 A.

Thermal Protection

Thermal Shutdown

The TPS51461 has an internal temperature sensor. When the temperature reaches a nominal 130°C, the device shuts down until the temperature cools by approximately 10°C. Then the converter restarts.

Startup and VID Transition Timing Diagrams

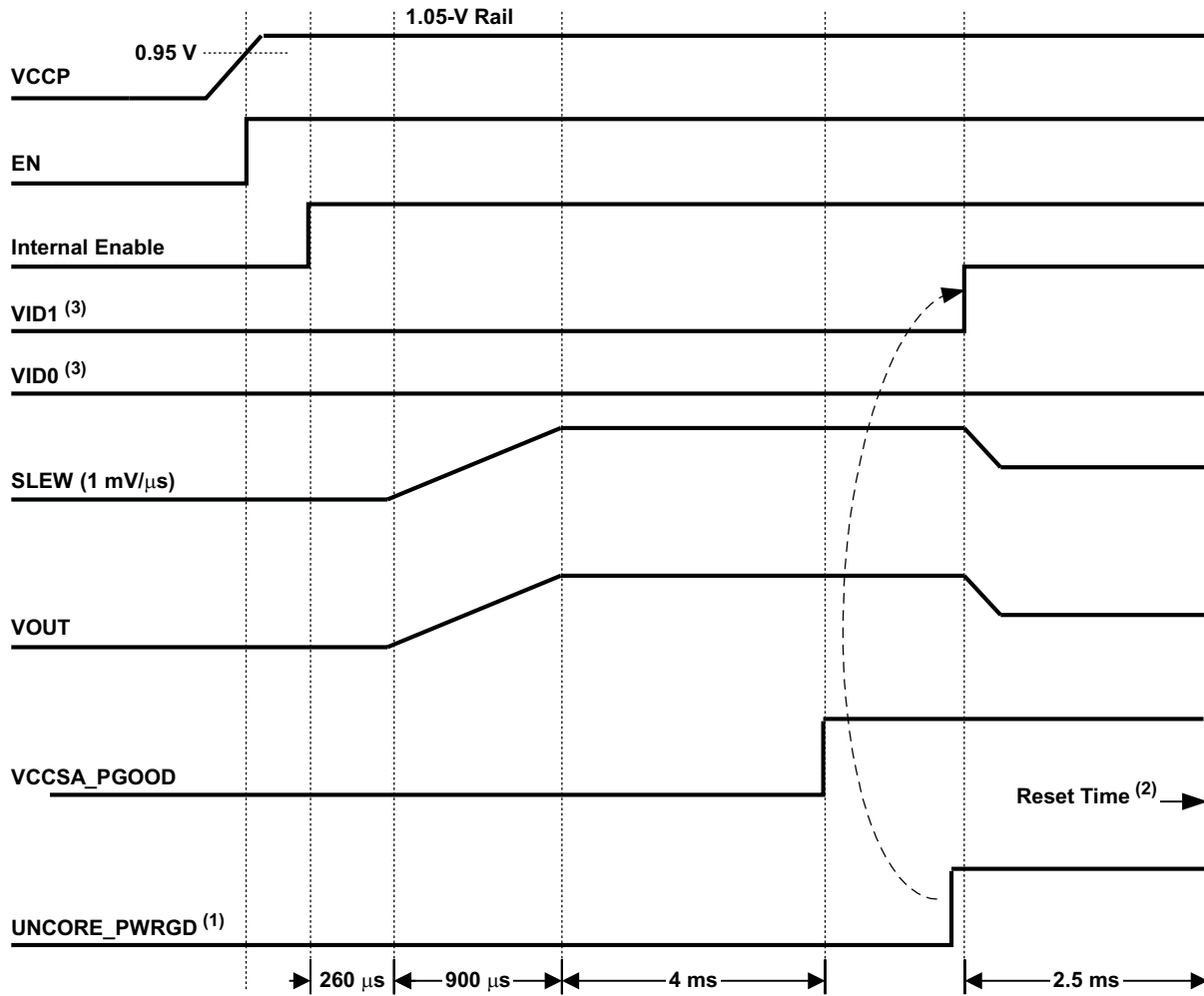

UDG-10191

Figure 11. Fixed VID/Fixed Step Startup and VID Toggle Timing Diagram for 2011 Intel Platform

For Figure 11:

- (1) Includes VCCA, VCCAXG, and VDDQ power rails.
- (2) Processor reset: VID transition must be completed by this time.
- (3) 1-kΩ pull-down resistor required.

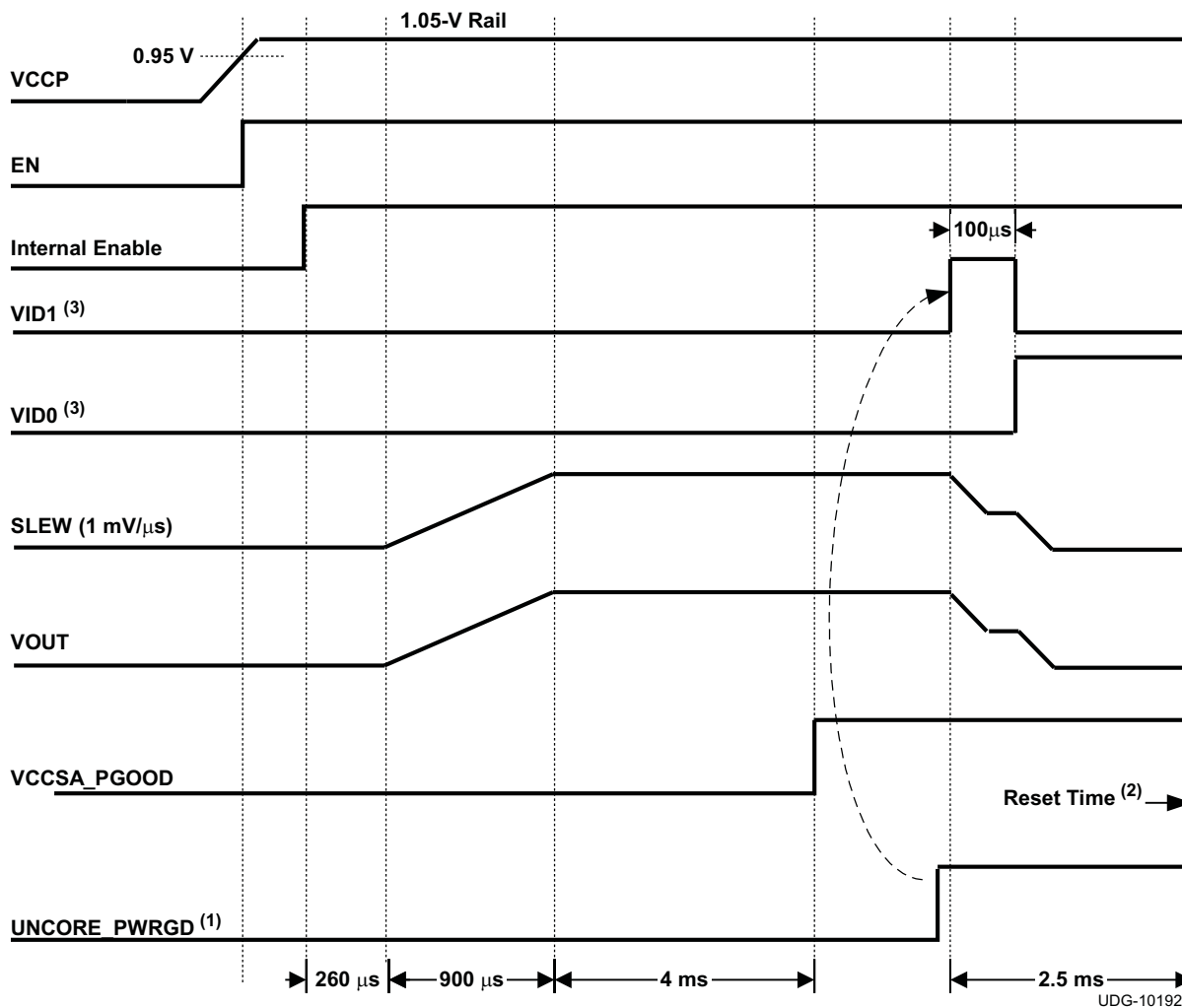

Figure 12. Fixed VID/Fixed Step Startup and VID Toggle Timing Diagram for 2012 Intel Platform

For Figure 12:

- (1) Includes VCCA, VCCAXG, and VDDQ power rails.
- (2) Processor reset: VID transition must be completed by this time.
- (3) 1-kΩ pull-down resistor required.

TYPICAL CHARACTERISTICS

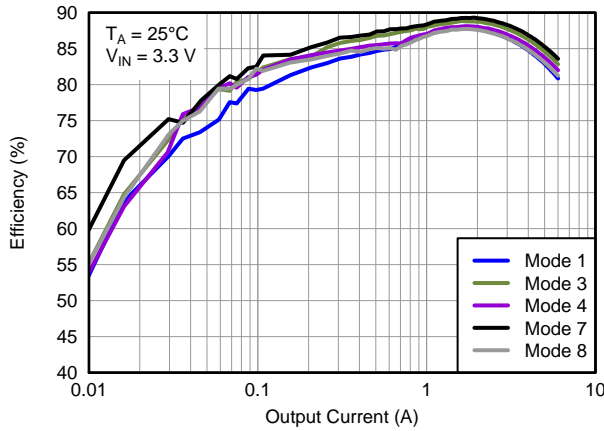

Figure 13. Efficiency vs Output Current

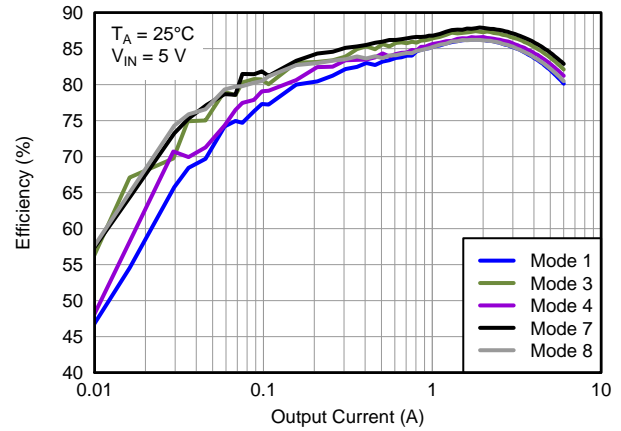

Figure 14. Efficiency vs Output Current

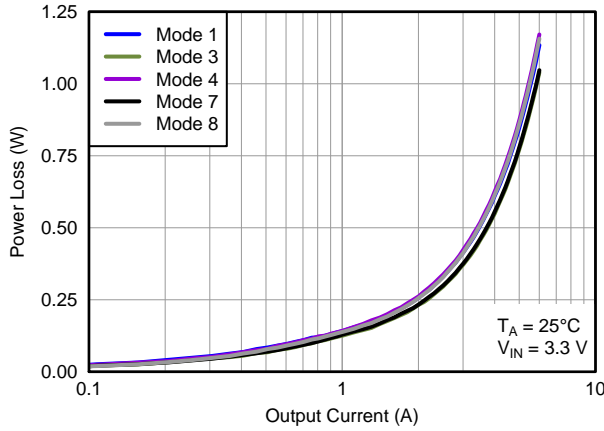

Figure 15. Power Loss

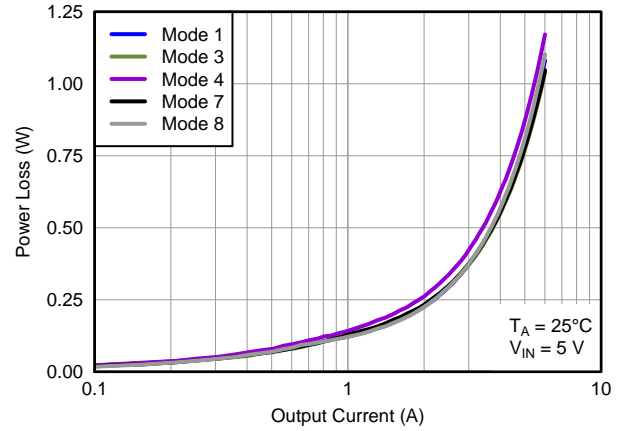

Figure 16. Power Loss

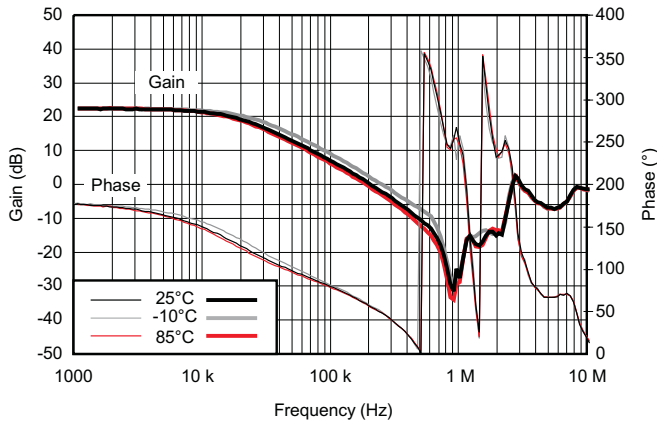

Figure 17. Bode Plot (Non-Droop Mode) $V_{IN} = 5 V$, $V_{OUT} = 0.8 V$, $I_{LOAD} = 5 A$

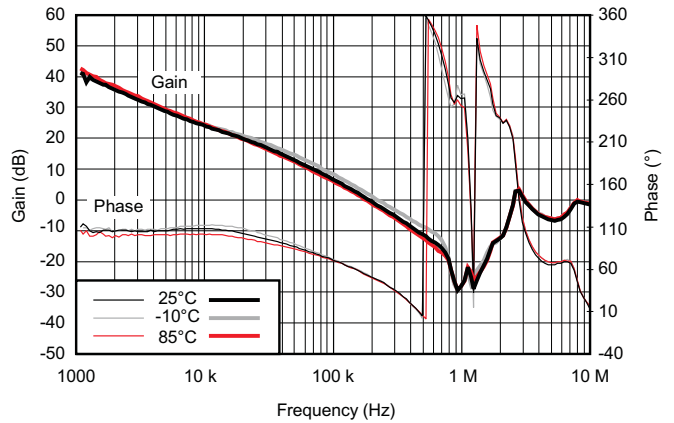

Figure 18. Bode Plot (Droop Mode), $V_{IN} = 5 V$, $V_{OUT} = 0.8 V$, $I_{LOAD} = 5 A$

TYPICAL CHARACTERISTICS (continued)

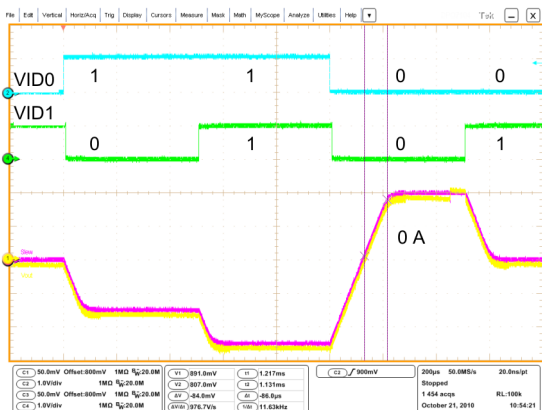

Figure 19. Mode 8 Non-Droop, 0 A

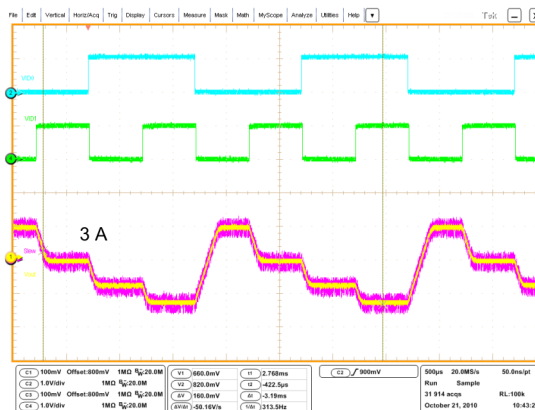

Figure 20. Mode 8 Non-Droop, 3 A

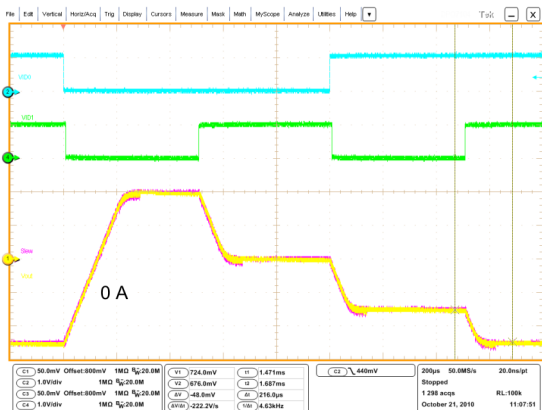

Figure 21. Mode 8 Droop, 0 A

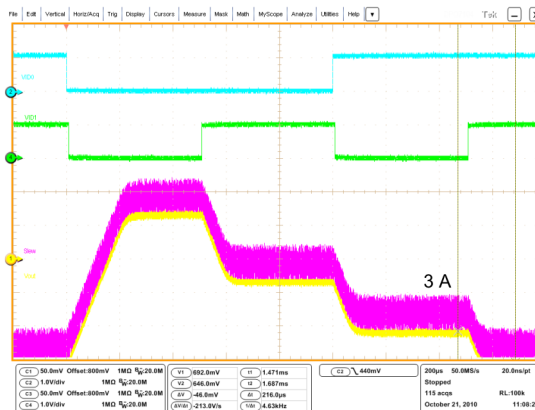

Figure 22. Mode 8 Droop, 3 A

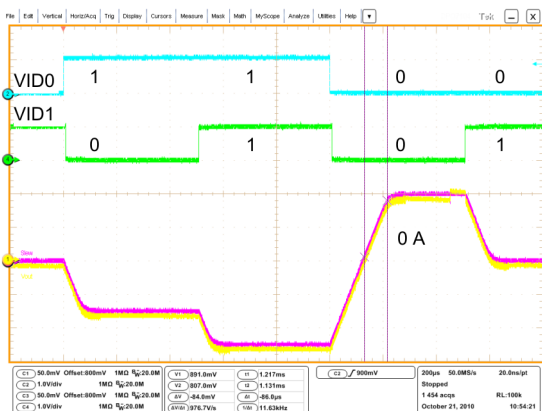

Figure 23. Mode 4 Non-Droop 0 A

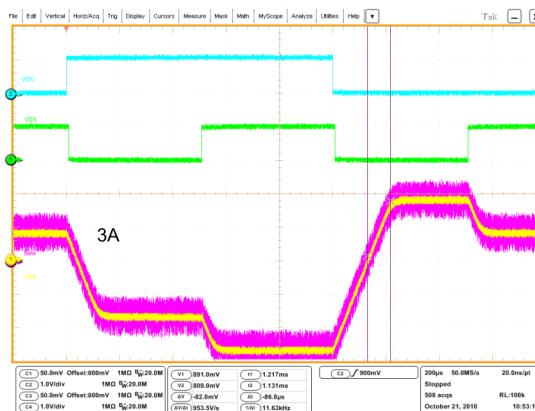

Figure 24. Mode 4 Non-Droop 3 A

TYPICAL CHARACTERISTICS (continued)

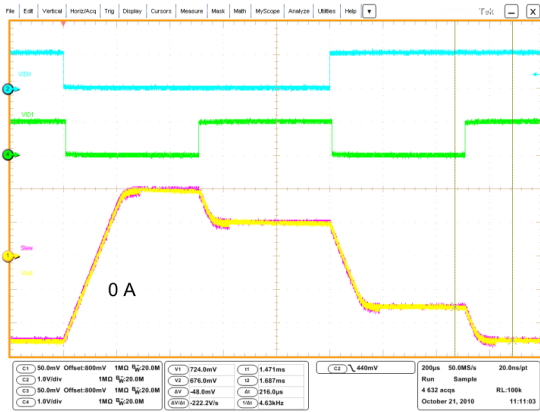

Figure 25. Mode 4 Droop 0 A

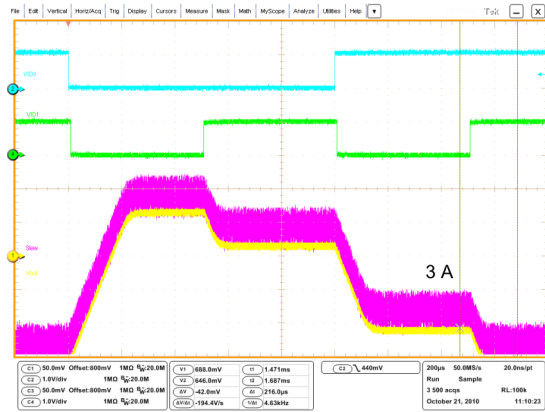

Figure 26. Mode 4 Droop 3 A

DESIGN PROCEDURE

The simplified design procedure is done for a non-droop application using the TPS51461 converter.

Step One

Determine the specifications.

The System Agent Rail requirements provide the following key parameters:

1. $V_{00} = 0.90 \text{ V}$
2. $V_{10} = 0.80 \text{ V}$
3. $I_{CC(\text{max})} = 6 \text{ A}$
4. $I_{DYN(\text{max})} = 2 \text{ A}$
5. $I_{CC(\text{tdc})} = 3 \text{ A}$

Step Two

Determine system parameters.

The input voltage range and operating frequency are of primary interest. For example:

1. $V_{IN} = 5 \text{ V}$
2. $f_{SW} = 1 \text{ MHz}$

Step Three

Determine inductor value and choose inductor.

Smaller values of inductor have better transient performance but higher ripple and lower efficiency. Higher values have the opposite characteristics. It is common practice to limit the ripple current to 25% to 50% of the maximum current. In this case, use 25%:

$$I_{P-P} = 6 \text{ A} \times 0.25 = 1.5 \text{ A} \quad (7)$$

At $f_{SW} = 1 \text{ MHz}$, with a 5-V input and a 0.80-V output:

$$L = \frac{V \times dT}{I_{P-P}} = \frac{(V_{IN} - V_{10}) \times \left(\frac{V_{10}}{f_{SW} \times V_{IN}} \right)}{I_{P-P}} = \frac{(5 - 0.8) \times \left(\frac{0.8}{(1 \times 5)} \right)}{1.5 \text{ A}} = 0.45 \mu\text{H} \quad (8)$$

For this application, a 0.42- μH , 1.55-m Ω inductor from NEC-TOKIN with part number MPCG0740LR42C is chosen.

Step Four

Set the output voltage.

The output voltage is determined by the VID settings. The actual voltage set point for each VID setting is listed in [Table 1](#). No external resistor dividers are needed for this design.

Step Five

Calculate C_{SLEW} .

VID pin transition and soft-start time is determined by C_{SLEW} and 10 μA of internal current source.

$$C_{SLEW} = \frac{I_{SLEW}}{SR_{DAC}} = \frac{10 \mu\text{A}}{1 \text{ mV} / \mu\text{s}} = 10 \text{ nF} \quad (9)$$

The slower slew rate is desired to minimize large inductor current perturbation during startup and voltage transition, thus reducing the possibility of acoustic noise.

Given the C_{SLEW} , use [Equation 10](#) to calculate the soft start time.

$$t_{SS} = \frac{C_{SLEW} \times 0.9V}{I_{SLEW}} = \frac{10nF \times 0.9V}{10\mu A} = 900 \mu s \quad (10)$$

Step Six

Calculate OCL.

The DC OCL level of TPS51461 design is determined by [Equation 11](#),

$$I_{OCL(dc)} = I_{OCL(valley)} + \frac{1}{2} \times I_{P-P} = 6A + \frac{1}{2} \times 1.5A = 6.75A \quad (11)$$

The minimum valley OCL is 6 A over process and temperature, and $I_{P-P} = 1.5 A$, the minimum DC OCL is calculated to be 6.75A.

Step Seven

Determine the output capacitance.

To determine C_{OUT} based on transient and stability requirement, first calculate the the minimum output capacitance for a given transient.

[Equation 13](#) and [Equation 12](#) can be used to estimate the amount of capacitance needed for a given dynamic load step/release. Please note that there are other factors that may impact the amount of output capacitance for a specific design, such as ripple and stability. [Equation 13](#) and [Equation 12](#) are used only to estimate the transient requirement, the result should be used in conjunction with other factors of the design to determine the necessary output capacitance for the application.

$$C_{OUT(min_under)} = \frac{L \times \Delta I_{LOAD(max)}^2 \times \left(\frac{V_{VOUT} \times t_{SW}}{V_{IN(min)}} + t_{MIN(off)} \right)}{2 \times \Delta V_{LOAD(insert)} \times \left(\left(\frac{V_{IN(min)} - V_{VOUT}}{V_{IN(min)}} \right) \times t_{SW} - t_{MIN(off)} \right) \times V_{VOUT}} \quad (12)$$

$$C_{OUT(min_over)} = \frac{L_{OUT} \times \left(\Delta I_{LOAD(max)} \right)^2}{2 \times \Delta V_{LOAD(release)} \times V_{VOUT}} \quad (13)$$

[Equation 12](#) and [Equation 13](#) calculate the minimum C_{OUT} for meeting the transient requirement, which is 72.9 μF assuming the following:

- $\pm 3\%$ voltage allowance for load step and release
- MLCC capacitance derating of 60% due to DC and AC bias effect

In this reference design, 4, 22- μF capacitors are used in order to provide this amount of capacitance.

Step Eight

Determine the stability based on the output capacitance C_{OUT} .

In order to achieve stable operation. The 0-dB frequency, f_0 should be kept less than 1/5 of the switching frequency (1 MHz). (See [Figure 4](#))

$$f_0 = \frac{1}{2\pi} \times \frac{G_M}{C_{OUT}} \times \frac{R_C}{R_S} = 150 \text{ kHz}$$

where

$$\bullet \quad R_S = R_{DS(on)} \times G_{MC} \times R_{LOAD} \quad (14)$$

$$R_C = \frac{f_0 \times R_S \times 2\pi \times C_{OUT}}{G_M} = \frac{150 \text{ kHz} \times 53 \text{ m}\Omega \times 2\pi \times 88 \mu\text{F}}{1 \text{ mS}} \approx 5 \text{ k}\Omega \quad (15)$$

Using 4, 22- μF capacitors, the compensation resistance, R_C can be calculated to be approximately 5 k Ω .

The purpose of the comparator capacitor (C_C) is to reduce the DC component to obtain high DC feedback gain. However, as it causes phase delay, another zero to cancel this effect at f_0 is needed. This zero can be determined by values of C_C and the compensation resistor, R_C .

$$f_z = \frac{1}{2\pi \times R_C \times C_C} = \frac{f_0}{10} \quad (16)$$

And since R_C has previously been derived, the value of C_C is calculated to be 2.2 nF. In order to further boost phase margin, a value of 3.3-nF is chosen for this reference design.

Step Nine

Select decoupling and peripheral components.

For TPS51461 peripheral capacitors use the following minimum values of ceramic capacitance. X5R or better temperature coefficient is recommended. Tighter tolerances and higher voltage ratings are always appropriate.

- V5DRV decoupling $\geq 2.2 \mu\text{F}$, $\geq 10 \text{ V}$
- V5FILT decoupling $\geq 1 \mu\text{F}$, $\geq 10 \text{ V}$
- VREF decoupling 0.22 μF to 1 μF , $\geq 4 \text{ V}$
- Bootstrap capacitors $\geq 0.1 \mu\text{F}$, $\geq 10 \text{ V}$
- Pull-up resistors on PGOOD, 100 k Ω

Layout Considerations

Good layout is essential for stable power supply operation. Follow these guidelines for an efficient PCB layout.

- Connect PGND pins (or at least one of the pins) to the thermal PAD underneath the device. Also connect GND pin to the thermal PAD underneath the device. Use four vias to connect the thermal pad to internal ground planes.
- Place VIN, V5DRV, V5FILT and 2VREF decoupling capacitors as close to the device as possible.
- Use wide traces for the VIN, VOUT, PGND and SW pins. These nodes carry high current and also serve as heat sinks.
- Place feedback and compensation components as close to the device as possible.
- Keep analog signals (SLEW, COMP) away from noisy signals (SW, VBST).

PACKAGING INFORMATION

Orderable Device	Status ⁽¹⁾	Package Type	Package Drawing	Pins	Package Qty	Eco Plan ⁽²⁾	Lead/ Ball Finish	MSL Peak Temp ⁽³⁾	Samples (Requires Login)
TPS51461RGER	ACTIVE	VQFN	RGE	24	3000	Green (RoHS & no Sb/Br)	CU NIPDAU	Level-2-260C-1 YEAR	Purchase Samples
TPS51461RGET	ACTIVE	VQFN	RGE	24	250	Green (RoHS & no Sb/Br)	CU NIPDAU	Level-2-260C-1 YEAR	Purchase Samples

⁽¹⁾ The marketing status values are defined as follows:

ACTIVE: Product device recommended for new designs.

LIFEBUY: TI has announced that the device will be discontinued, and a lifetime-buy period is in effect.

NRND: Not recommended for new designs. Device is in production to support existing customers, but TI does not recommend using this part in a new design.

PREVIEW: Device has been announced but is not in production. Samples may or may not be available.

OBsolete: TI has discontinued the production of the device.

⁽²⁾ Eco Plan - The planned eco-friendly classification: Pb-Free (RoHS), Pb-Free (RoHS Exempt), or Green (RoHS & no Sb/Br) - please check <http://www.ti.com/productcontent> for the latest availability information and additional product content details.

TBD: The Pb-Free/Green conversion plan has not been defined.

Pb-Free (RoHS): TI's terms "Lead-Free" or "Pb-Free" mean semiconductor products that are compatible with the current RoHS requirements for all 6 substances, including the requirement that lead not exceed 0.1% by weight in homogeneous materials. Where designed to be soldered at high temperatures, TI Pb-Free products are suitable for use in specified lead-free processes.

Pb-Free (RoHS Exempt): This component has a RoHS exemption for either 1) lead-based flip-chip solder bumps used between the die and package, or 2) lead-based die adhesive used between the die and leadframe. The component is otherwise considered Pb-Free (RoHS compatible) as defined above.

Green (RoHS & no Sb/Br): TI defines "Green" to mean Pb-Free (RoHS compatible), and free of Bromine (Br) and Antimony (Sb) based flame retardants (Br or Sb do not exceed 0.1% by weight in homogeneous material)

⁽³⁾ MSL, Peak Temp. -- The Moisture Sensitivity Level rating according to the JEDEC industry standard classifications, and peak solder temperature.

Important Information and Disclaimer: The information provided on this page represents TI's knowledge and belief as of the date that it is provided. TI bases its knowledge and belief on information provided by third parties, and makes no representation or warranty as to the accuracy of such information. Efforts are underway to better integrate information from third parties. TI has taken and continues to take reasonable steps to provide representative and accurate information but may not have conducted destructive testing or chemical analysis on incoming materials and chemicals. TI and TI suppliers consider certain information to be proprietary, and thus CAS numbers and other limited information may not be available for release.

In no event shall TI's liability arising out of such information exceed the total purchase price of the TI part(s) at issue in this document sold by TI to Customer on an annual basis.

TAPE AND REEL INFORMATION

QUADRANT ASSIGNMENTS FOR PIN 1 ORIENTATION IN TAPE

*All dimensions are nominal

Device	Package Type	Package Drawing	Pins	SPQ	Reel Diameter (mm)	Reel Width W1 (mm)	A0 (mm)	B0 (mm)	K0 (mm)	P1 (mm)	W (mm)	Pin1 Quadrant
TPS51461RGER	VQFN	RGE	24	3000	330.0	12.4	4.25	4.25	1.15	8.0	12.0	Q2
TPS51461RGET	VQFN	RGE	24	250	180.0	12.4	4.25	4.25	1.15	8.0	12.0	Q2

TAPE AND REEL BOX DIMENSIONS

*All dimensions are nominal

Device	Package Type	Package Drawing	Pins	SPQ	Length (mm)	Width (mm)	Height (mm)
TPS51461RGER	VQFN	RGE	24	3000	346.0	346.0	29.0
TPS51461RGET	VQFN	RGE	24	250	190.5	212.7	31.8

RGE (S-PVQFN-N24)

PLASTIC QUAD FLATPACK NO-LEAD

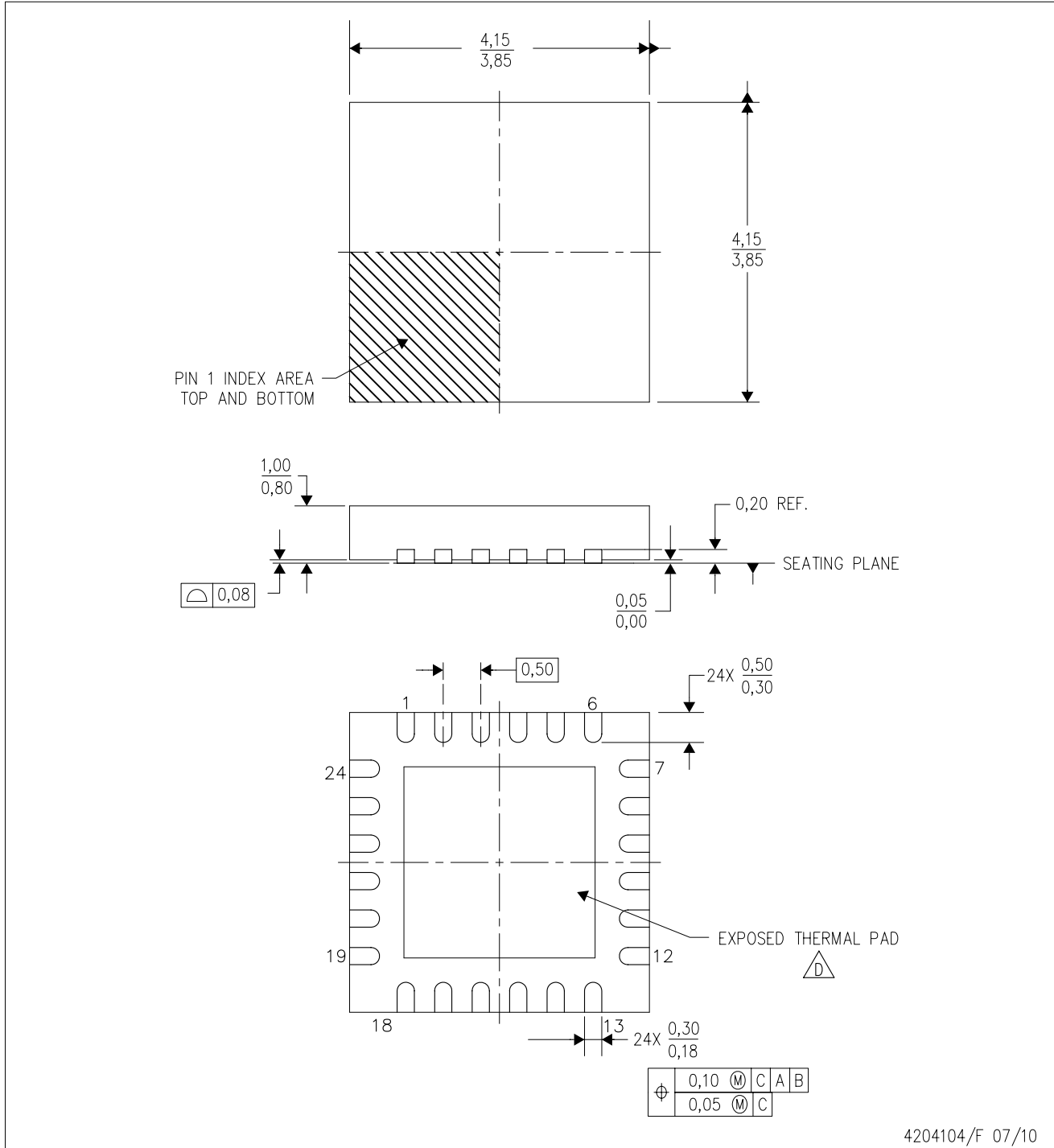

4204104/F 07/10

- NOTES:
- A. All linear dimensions are in millimeters. Dimensioning and tolerancing per ASME Y14.5M-1994.
 - B. This drawing is subject to change without notice.
 - C. Quad Flatpack, No-Leads (QFN) package configuration.
 - $\triangle D$ The package thermal pad must be soldered to the board for thermal and mechanical performance. See the Product Data Sheet for details regarding the exposed thermal pad dimensions.
 - E. Falls within JEDEC MO-220.

THERMAL PAD MECHANICAL DATA

RGE (S-PVQFN-N24)

PLASTIC QUAD FLATPACK NO-LEAD

THERMAL INFORMATION

This package incorporates an exposed thermal pad that is designed to be attached directly to an external heatsink. The thermal pad must be soldered directly to the printed circuit board (PCB). After soldering, the PCB can be used as a heatsink. In addition, through the use of thermal vias, the thermal pad can be attached directly to the appropriate copper plane shown in the electrical schematic for the device, or alternatively, can be attached to a special heatsink structure designed into the PCB. This design optimizes the heat transfer from the integrated circuit (IC).

For information on the Quad Flatpack No-Lead (QFN) package and its advantages, refer to Application Report, QFN/SON PCB Attachment, Texas Instruments Literature No. SLUA271. This document is available at www.ti.com.

The exposed thermal pad dimensions for this package are shown in the following illustration.

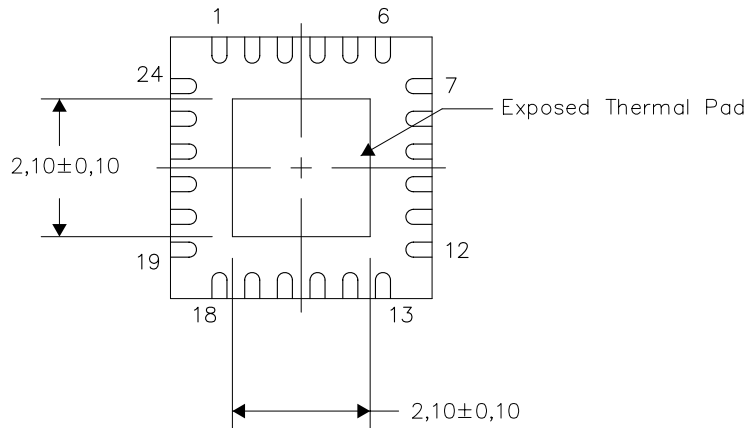

Bottom View

Exposed Thermal Pad Dimensions

4206344-6/W 01/11

NOTES: A. All linear dimensions are in millimeters

IMPORTANT NOTICE

Texas Instruments Incorporated and its subsidiaries (TI) reserve the right to make corrections, modifications, enhancements, improvements, and other changes to its products and services at any time and to discontinue any product or service without notice. Customers should obtain the latest relevant information before placing orders and should verify that such information is current and complete. All products are sold subject to TI's terms and conditions of sale supplied at the time of order acknowledgment.

TI warrants performance of its hardware products to the specifications applicable at the time of sale in accordance with TI's standard warranty. Testing and other quality control techniques are used to the extent TI deems necessary to support this warranty. Except where mandated by government requirements, testing of all parameters of each product is not necessarily performed.

TI assumes no liability for applications assistance or customer product design. Customers are responsible for their products and applications using TI components. To minimize the risks associated with customer products and applications, customers should provide adequate design and operating safeguards.

TI does not warrant or represent that any license, either express or implied, is granted under any TI patent right, copyright, mask work right, or other TI intellectual property right relating to any combination, machine, or process in which TI products or services are used. Information published by TI regarding third-party products or services does not constitute a license from TI to use such products or services or a warranty or endorsement thereof. Use of such information may require a license from a third party under the patents or other intellectual property of the third party, or a license from TI under the patents or other intellectual property of TI.

Reproduction of TI information in TI data books or data sheets is permissible only if reproduction is without alteration and is accompanied by all associated warranties, conditions, limitations, and notices. Reproduction of this information with alteration is an unfair and deceptive business practice. TI is not responsible or liable for such altered documentation. Information of third parties may be subject to additional restrictions.

Resale of TI products or services with statements different from or beyond the parameters stated by TI for that product or service voids all express and any implied warranties for the associated TI product or service and is an unfair and deceptive business practice. TI is not responsible or liable for any such statements.

TI products are not authorized for use in safety-critical applications (such as life support) where a failure of the TI product would reasonably be expected to cause severe personal injury or death, unless officers of the parties have executed an agreement specifically governing such use. Buyers represent that they have all necessary expertise in the safety and regulatory ramifications of their applications, and acknowledge and agree that they are solely responsible for all legal, regulatory and safety-related requirements concerning their products and any use of TI products in such safety-critical applications, notwithstanding any applications-related information or support that may be provided by TI. Further, Buyers must fully indemnify TI and its representatives against any damages arising out of the use of TI products in such safety-critical applications.

TI products are neither designed nor intended for use in military/aerospace applications or environments unless the TI products are specifically designated by TI as military-grade or "enhanced plastic." Only products designated by TI as military-grade meet military specifications. Buyers acknowledge and agree that any such use of TI products which TI has not designated as military-grade is solely at the Buyer's risk, and that they are solely responsible for compliance with all legal and regulatory requirements in connection with such use.

TI products are neither designed nor intended for use in automotive applications or environments unless the specific TI products are designated by TI as compliant with ISO/TS 16949 requirements. Buyers acknowledge and agree that, if they use any non-designated products in automotive applications, TI will not be responsible for any failure to meet such requirements.

Following are URLs where you can obtain information on other Texas Instruments products and application solutions:

Products

Audio	www.ti.com/audio
Amplifiers	amplifier.ti.com
Data Converters	dataconverter.ti.com
DLP® Products	www.dlp.com
DSP	dsp.ti.com
Clocks and Timers	www.ti.com/clocks
Interface	interface.ti.com
Logic	logic.ti.com
Power Mgmt	power.ti.com
Microcontrollers	microcontroller.ti.com
RFID	www.ti-rfid.com
RF/IF and ZigBee® Solutions	www.ti.com/lprf

Applications

Communications and Telecom	www.ti.com/communications
Computers and Peripherals	www.ti.com/computers
Consumer Electronics	www.ti.com/consumer-apps
Energy and Lighting	www.ti.com/energy
Industrial	www.ti.com/industrial
Medical	www.ti.com/medical
Security	www.ti.com/security
Space, Avionics and Defense	www.ti.com/space-avionics-defense
Transportation and Automotive	www.ti.com/automotive
Video and Imaging	www.ti.com/video
Wireless	www.ti.com/wireless-apps

TI E2E Community Home Page

e2e.ti.com

Mailing Address: Texas Instruments, Post Office Box 655303, Dallas, Texas 75265
Copyright © 2011, Texas Instruments Incorporated