

## General Description

The DW01 Plus battery protection IC is designed to protect lithium-ion/polymer battery from damage or degrading the lifetime due to overcharge, overdischarge, and/or overcurrent for one-cell lithium-ion/polymer battery powered systems, such as cellular phones.

The ultra-small package and less required external components make it ideal to integrate the DW01 Plus into the limited space of battery pack. The accurate  $\pm 50\text{mV}$  overcharging detection voltage ensures safe and full utilization charging. The very low standby current drains little current from the cell while in storage.

## Features

- **Reduction in Board Size due to Miniature Package SOT-23-6.**
- **Ultra-Low Quiescent Current at  $3\ \mu\text{A}$  ( $V_{\text{CC}}=3.9\text{V}$ ).**
- **Ultra-Low Power-Down Current at  $0.1\ \mu\text{A}$  ( $V_{\text{CC}}=2.0\text{V}$ ).**
- **Precision Overcharge Protection Voltage  $4.3\text{V} \pm 50\text{mV}$  for the DW01 Plus**
- **Load Detection Function during Overcharge Mode.**
- **Two Detection Levels for Overcurrent Protection.**
- **Delay times are generated by internal circuits. No external capacitors required.**

## Ordering Information

DW01A

PACKAGE TYPE  
SOT-23-6

TEMPERATURE RANGE  
 $-40^{\circ}\text{C}\sim+85^{\circ}\text{C}$

OVERCHARGE PROTECTION  
 $4.3\text{V} \pm 50\text{mV}$

## Applications

- **Protection IC for One-Cell Lithium-Ion / Lithium-Polymer Battery Pack**

**Product Name List**

Model	Package	Overcharge detection voltage [V <sub>OCF</sub> ] (V)	Overcharge release voltage [V <sub>OCR</sub> ] (V)	Overdischarge detection voltage [V <sub>ODP</sub> ] (V)	Overdischarge release voltage [V <sub>ODR</sub> ] (V)	Overcurrent detection voltage [V <sub>OI1</sub> ] (mV)
	SOT-23-6					
DW01	DW01A	4.300±0.050	4.100±0.050	2.40±0.100	3.0±0.100	150±30

**Pin Configuration**

Pin No.	Symbol	Description
1	OD	MOSFET gate connection pin for discharge control
2	CS	Input pin for current sense, charger detect
3	OC	MOSFET gate connection pin for charge control
4	TD	Test pin for reduce delay time
5	VCC	Power supply, through a resistor (R1)
6	GND	Ground pin

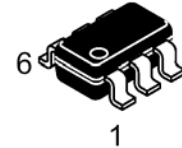
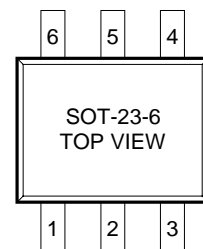

**Functional Block Diagram**

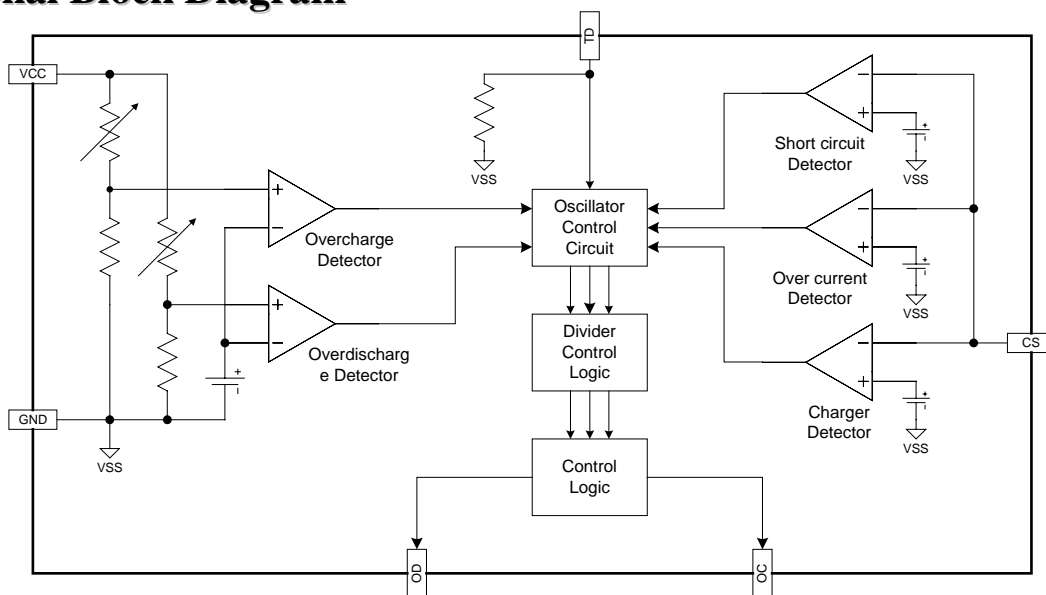

### Typical Application Circuit

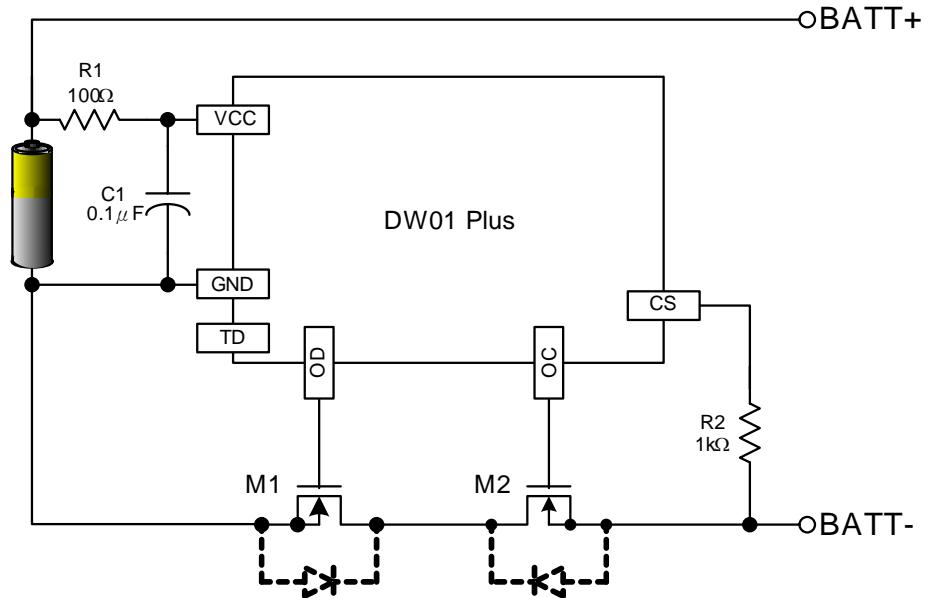

### Absolute Maximum Ratings

(VSS=0V, Ta=25°C unless otherwise specified)

Item	Symbol	Rating	Unit
Input voltage between VDD and VSS *	VDD	VSS-0.3 to VSS+10	V
OC output pin voltage	VOC	VDD-26 to VDD+0.3	V
OD output pin voltage	VOD	VSS-0.3 to VDD+0.3	V
CS input pin voltage	VCS	VDD-26 to VDD+0.3	V
Operating Temperature Range	TOP	-40 to +85	°C
Storage Temperature Range	TST	-40 to +125	°C

Note: DW01 Plus contains a circuit that will protect it from static discharge; but please take special care that no excessive static electricity or voltage which exceeds the limit of the protection circuit will be applied to it.

## Electrical Characteristics

(Ta=25 °C unless otherwise specified)

PARAMETER	TEST CONDITIONS	SYMBOL	Min	Typ	Max	UNIT
Supply Current	VCC=3.9V	ICC		3.0	6.0	μA
Power-Down Current	VCC=2.0V	IPD			0.1	μA
Overcharge Protection Voltage	DW01 Plus	VOCP	4.25	4.30	4.35	V
Overcharge Release Voltage		VOCR	4.05	4.10	4.15	V
Overdischarge Protection Voltage		VODP	2.30	2.40	2.50	V
Overdischarge Release Voltage		VODR	2.90	3.00	3.10	V
Overcurrent Protection Voltage		VOIP (VOI1)	120	150	180	mV
Short Current Protection Voltage	VCC=3.6V	VSIP (VOI2)	1.25	1.35	1.45	V
Overcharge Delay Time		TOC		80	200	ms
Overdischarge Delay Time	VCC=3.6V to 2.0V	TOD		40	100	ms
Overcurrent Delay Time (1)	VCC=3.6V	TOI1		10	20	ms
Overcurrent Delay Time (2)	VCC=3.6V	TOI2		5	50	μs
Charger Detection Threshold Voltage		VCH	-1.2	-0.7	-0.2	V
OD Pin Output "H" Voltage		VDH	VCC-0.1	VCC-0.02		V
OD Pin Output "L" Voltage		VDL		0.1	0.5	V
OC Pin Output "H" Voltage		VCH	VCC-0.1	VCC-0.02		V
OC Pin Output "L" Voltage		VCL		0.1	0.5	V

## Timing Diagram

### 1. Overcharge Condition → Load Discharging → Normal Condition

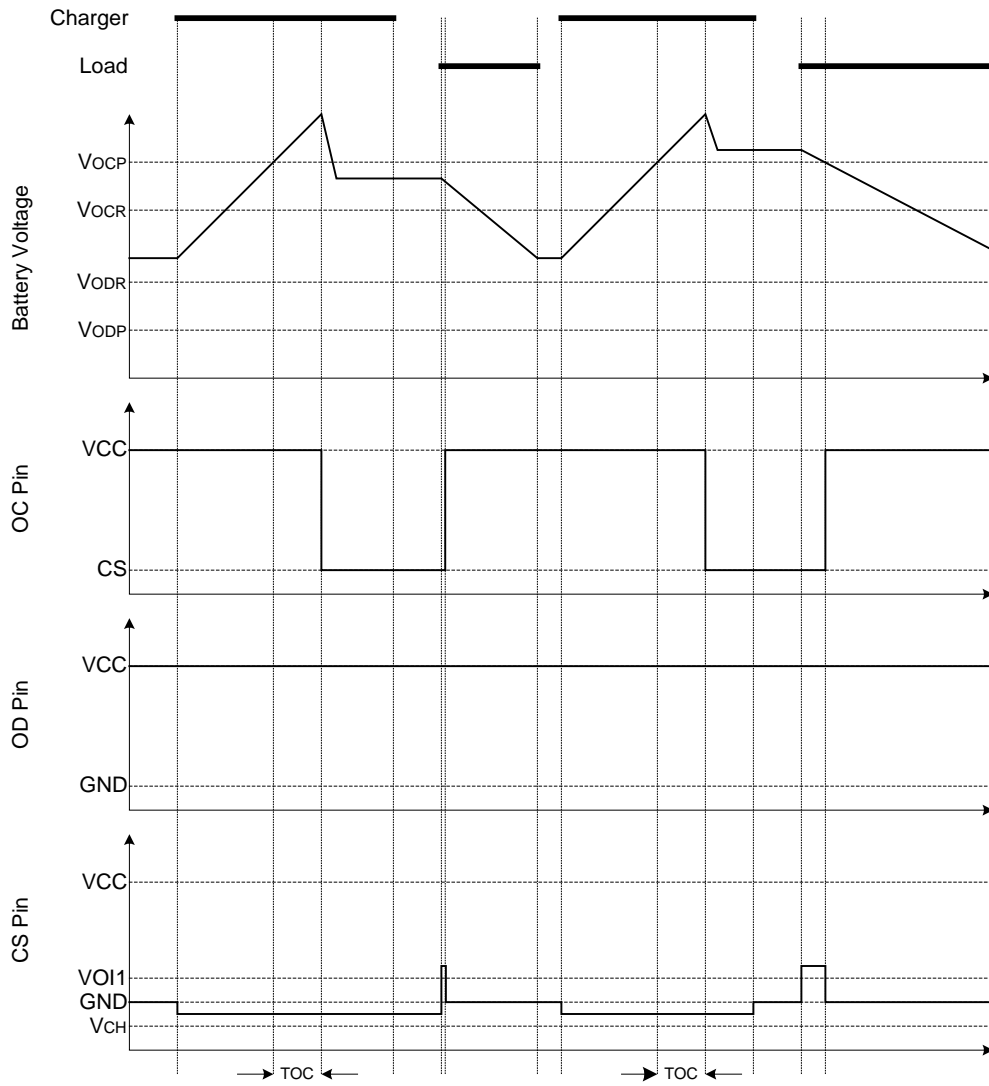

2. Overdischarge Condition → Charging by a Charger → Normal Condition

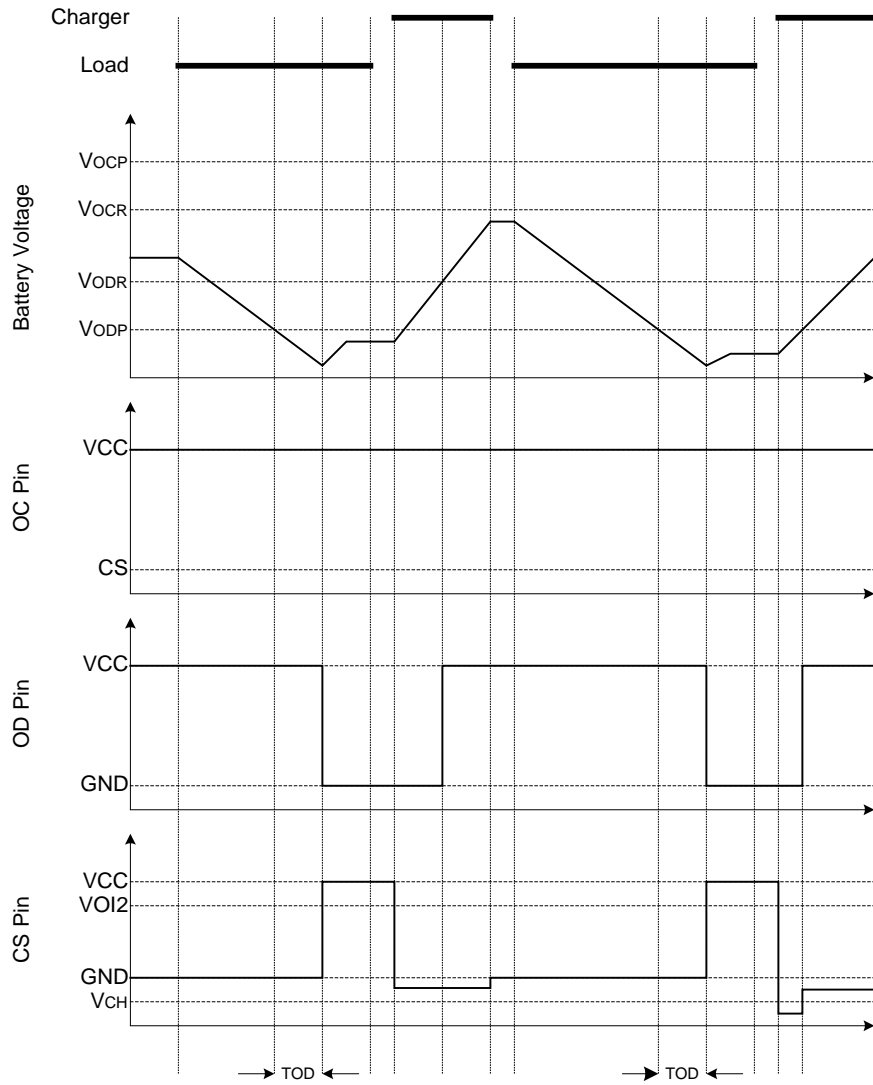

3. Over Current Condition → Normal Condition

