

# **TAS5508B**

***8-Channel Digital Audio PWM Processor***

*Data Manual*



**TAS5508B**  
**8-Channel Digital Audio PWM Processor**

***Data Manual***



Literature Number: SLES162B  
December 2005–Revised April 2006

PRODUCTION DATA information is current as of publication date.  
Products conform to specifications per the terms of the Texas  
Instruments standard warranty. Production processing does not  
necessarily include testing of all parameters.



## Contents

|          |   |           |
|----------|---|-----------|
| <b>1</b> | <b>Introduction</b> .....   | <b>11</b> |
| 1.1      | Features .....  | 11        |
| 1.2      | Overview.....   | 12        |
| 1.3      | Changes From the TAS5508A to the TAS5508B .....                       | 14        |
| 1.4      | TAS5508B System Diagrams.....   | 15        |
| <b>2</b> | <b>Description</b> .....  | <b>17</b> |
| 2.1      | Physical Characteristics .....  | 17        |
| 2.1.1    | Terminal Assignments .....  | 17        |
| 2.1.2    | Ordering Information .....  | 17        |
| 2.1.3    | Terminal Descriptions.....  | 18        |
| 2.2      | TAS5508B Functional Description .....                                 | 20        |
| 2.2.1    | Power Supply .....  | 20        |
| 2.2.2    | Clock, PLL, and Serial Data Interface .....                           | 20        |
| 2.2.3    | I <sup>2</sup> C Serial-Control Interface .....                       | 21        |
| 2.2.4    | Device Control .....  | 21        |
| 2.2.5    | Digital Audio Processor (DAP).....                                    | 21        |
| 2.3      | TAS5508B DAP Architecture .....                                       | 23        |
| 2.3.1    | TAS5508B DAP Architecture Diagrams .....                              | 23        |
| 2.3.2    | I <sup>2</sup> C Coefficient Number Formats .....                     | 26        |
| 2.4      | Input Crossbar Mixer.....   | 30        |
| 2.5      | Biquad Filters .....  | 30        |
| 2.6      | Bass and Treble Controls .....  | 31        |
| 2.7      | Volume, Automute, and Mute.....                                       | 32        |
| 2.8      | Automute and Mute Channel Controls .....                              | 33        |
| 2.9      | Loudness Compensation .....   | 34        |
| 2.9.1    | Loudness Example.....   | 35        |
| 2.10     | Dynamic Range Control (DRC).....                                      | 35        |
| 2.10.1   | DRC Implementation .....  | 38        |
| 2.10.2   | Compression/Expansion Coefficient Computation Engine Parameters ..... | 39        |
| 2.11     | Output Mixer .....  | 41        |
| 2.12     | PWM .....   | 41        |
| 2.12.1   | DC Blocking (High-Pass Filter Enable/Disable) .....                   | 42        |
| 2.12.2   | De-Emphasis Filter .....  | 42        |
| 2.12.3   | Power-Supply Volume Control (PSVC).....                               | 43        |
| 2.12.4   | AM Interference Avoidance .....                                       | 44        |
| <b>3</b> | <b>TAS5508B Controls and Status</b> .....                             | <b>45</b> |
| 3.1      | I <sup>2</sup> C Status Registers .....                               | 45        |
| 3.1.1    | General Status Register (0x01).....                                   | 45        |
| 3.1.2    | Error Status Register (0x02) .....                                    | 45        |
| 3.2      | TAS5508B Pin Controls .....   | 45        |
| 3.2.1    | Reset (RESET) .....   | 45        |
| 3.2.2    | Power Down (PDN) .....  | 47        |
| 3.2.3    | Back-End Error (BKND_ERR) .....                                       | 47        |
| 3.2.4    | Speaker/Headphone Selector (HP_SEL).....                              | 48        |
| 3.2.5    | Mute (MUTE).....  | 48        |
| 3.3      | Device Configuration Controls.....                                    | 49        |
| 3.3.1    | Channel Configuration Registers .....                                 | 49        |
| 3.3.2    | Headphone Configuration Registers .....                               | 50        |
| 3.3.3    | Audio System Configurations .....                                     | 50        |
| 3.3.4    | Recovery from Clock Error .....                                       | 51        |

|          |  |                           |
|----------|--|---------------------------|
| 3.3.5    | Power-Supply Volume-Control Enable .....   | <a href="#">51</a>        |
| 3.3.6    | Volume and Mute Update Rate .....  | <a href="#">51</a>        |
| 3.3.7    | Modulation Index Limit .....   | <a href="#">51</a>        |
| 3.4      | Master Clock and Serial Data Rate Controls .....   | <a href="#">52</a>        |
| 3.4.1    | PLL Operation.....   | <a href="#">52</a>        |
| 3.5      | Bank Controls.....   | <a href="#">52</a>        |
| 3.5.1    | Manual Bank Selection .....  | <a href="#">53</a>        |
| 3.5.2    | Automatic Bank Selection .....   | <a href="#">53</a>        |
| 3.5.3    | Bank Set .....   | <a href="#">53</a>        |
| 3.5.4    | Bank-Switch Timeline .....   | <a href="#">54</a>        |
| 3.5.5    | Bank-Switching Example 1 .....   | <a href="#">54</a>        |
| 3.5.6    | Bank-Switching Example 2.....  | <a href="#">54</a>        |
| <b>4</b> | <b>Electrical Specifications .....</b>   | <b><a href="#">55</a></b> |
| 4.1      | Absolute Maximum Ratings .....   | <a href="#">55</a>        |
| 4.2      | Dissipation Rating Table (High-k Board, 105°C Junction) .....  | <a href="#">55</a>        |
| 4.3      | Dynamic Performance at Recommended Operating Conditions at 25°C.....   | <a href="#">55</a>        |
| 4.4      | Recommended Operating Conditions .....   | <a href="#">55</a>        |
| 4.5      | Electrical Characteristics .....   | <a href="#">56</a>        |
| 4.6      | PWM Operation.....   | <a href="#">56</a>        |
| 4.7      | Switching Characteristics.....   | <a href="#">56</a>        |
| 4.7.1    | Clock Signals.....   | <a href="#">56</a>        |
| 4.7.2    | Serial Audio Port.....   | <a href="#">57</a>        |
| 4.7.3    | TAS5508B Pin-Related Characteristics of the SDA and SCL I/O Stages for F/S-Mode I <sup>2</sup> C-Bus Devices ..... | <a href="#">57</a>        |
| 4.7.4    | TAS5508B Bus-Related Characteristics of the SDA and SCL I/O Stages for F/S-Mode I <sup>2</sup> C-Bus Devices ..... | <a href="#">58</a>        |
| 4.7.5    | Reset Timing ( $\overline{\text{RESET}}$ ) .....   | <a href="#">60</a>        |
| 4.7.6    | Power-Down ( $\overline{\text{PDN}}$ ) Timing .....  | <a href="#">60</a>        |
| 4.7.7    | Back-End Error ( $\overline{\text{BKND\_ERR}}$ ) .....   | <a href="#">61</a>        |
| 4.7.8    | Mute Timing ( $\overline{\text{MUTE}}$ ).....  | <a href="#">61</a>        |
| 4.7.9    | Headphone Select ( $\overline{\text{HP\_SEL}}$ ).....  | <a href="#">62</a>        |
| 4.7.10   | Volume Control .....   | <a href="#">62</a>        |
| 4.8      | Serial Audio Interface Control and Timing .....  | <a href="#">63</a>        |
| 4.8.1    | I <sup>2</sup> S Timing .....  | <a href="#">63</a>        |
| 4.8.2    | Left-Justified Timing.....   | <a href="#">64</a>        |
| 4.8.3    | Right-Justified Timing.....  | <a href="#">65</a>        |
| <b>5</b> | <b>I<sup>2</sup>C Serial-Control Interface (Slave Addresses 0x36 and 0x37) .....</b>                               | <b><a href="#">66</a></b> |
| 5.1      | General I <sup>2</sup> C Operation .....   | <a href="#">66</a>        |
| 5.2      | Single- and Multiple-Byte Transfers .....  | <a href="#">67</a>        |
| 5.3      | Single-Byte Write .....  | <a href="#">67</a>        |
| 5.4      | Multiple-Byte Write .....  | <a href="#">68</a>        |
| 5.5      | Incremental Multiple-Byte Write .....  | <a href="#">68</a>        |
| 5.6      | Single-Byte Read.....  | <a href="#">69</a>        |
| 5.7      | Multiple-Byte Read .....   | <a href="#">69</a>        |
| <b>6</b> | <b>Serial-Control I<sup>2</sup>C Register Summary .....</b>  | <b><a href="#">70</a></b> |
| <b>7</b> | <b>Serial-Control Interface Register Definitions .....</b>   | <b><a href="#">74</a></b> |
| 7.1      | Clock Control Register (0x00) .....  | <a href="#">74</a>        |
| 7.2      | General Status Register 0 (0x01) .....   | <a href="#">74</a>        |
| 7.3      | System Control Register 1 (0x03).....  | <a href="#">74</a>        |
| 7.4      | System Control Register 2 (0x04).....  | <a href="#">75</a>        |
| 7.5      | Channel Configuration Control Registers (0x05–0x0C) .....  | <a href="#">75</a>        |
| 7.6      | Headphone Configuration Control Register (0x0D).....   | <a href="#">76</a>        |
| 7.7      | Serial Data Interface Control Register (0x0E).....   | <a href="#">76</a>        |

|          |  |                            |
|----------|--|----------------------------|
| 7.8      | Soft Mute Register (0x0F).....   | <a href="#">77</a>         |
| 7.9      | Automute Control Register (0x14) .....                                       | <a href="#">78</a>         |
| 7.10     | Output Automute PWM Threshold and Back-End Reset Period Register (0x15)..... | <a href="#">79</a>         |
| 7.11     | Modulation Index Limit Register (0x16) .....                                 | <a href="#">80</a>         |
| 7.12     | Bank-Switching Command Register (0x40).....                                  | <a href="#">81</a>         |
| 7.13     | Input Mixer Registers, Channels 1–8 (0x41–0x48) .....                        | <a href="#">82</a>         |
| 7.14     | Bass Management Registers (0x49–0x50) .....                                  | <a href="#">85</a>         |
| 7.15     | Biquad Filter Register (0x51–0x88) .....                                     | <a href="#">85</a>         |
| 7.16     | Bass and Treble Bypass Register, Channels 1–8 (0x89–0x90) .....              | <a href="#">86</a>         |
| 7.17     | Loudness Registers (0x91–0x95) .....   | <a href="#">86</a>         |
| 7.18     | DRC1 Control Registers, Channels 1–7 (0x96) .....                            | <a href="#">87</a>         |
| 7.19     | DRC2 Control Register, Channel 8 (0x97).....                                 | <a href="#">88</a>         |
| 7.20     | DRC1 Data Registers (0x98–0x9C) .....  | <a href="#">88</a>         |
| 7.21     | DRC2 Data Registers (0x9D–0xA1) .....  | <a href="#">89</a>         |
| 7.22     | DRC Bypass Registers (0xA2–0xA9).....  | <a href="#">89</a>         |
| 7.23     | 8×2 Output Mixer Registers (0xAA–0xAF) .....                                 | <a href="#">89</a>         |
| 7.24     | 8×3 Output Mixer Registers (0xB0–0xB1) .....                                 | <a href="#">91</a>         |
| 7.25     | PSVC Volume Biquad Register (0xCF) .....                                     | <a href="#">92</a>         |
| 7.26     | Volume, Treble, and Bass Slew Rates Register (0xD0) .....                    | <a href="#">93</a>         |
| 7.27     | Volume Registers (0xD1–0xD9).....  | <a href="#">93</a>         |
| 7.28     | Bass Filter Set Register (0xDA) .....  | <a href="#">95</a>         |
| 7.29     | Bass Filter Index Register (0xDB) .....                                      | <a href="#">96</a>         |
| 7.30     | Treble Filter Set Register (0xDC) .....                                      | <a href="#">97</a>         |
| 7.31     | Treble Filter Index (0xDD).....  | <a href="#">98</a>         |
| 7.32     | AM Mode Register (0xDE) .....  | <a href="#">99</a>         |
| 7.33     | PSVC Range Register (0xDF) .....   | <a href="#">100</a>        |
| 7.34     | General Control Register (0xE0).....   | <a href="#">100</a>        |
| 7.35     | Incremental Multiple-Byte Write Append Register (0xFE).....                  | <a href="#">100</a>        |
| <b>8</b> | <b>TAS5508B Example Application Schematic.....</b>                           | <b><a href="#">102</a></b> |

## List of Figures

|      |  |    |
|------|--|----|
| 1-1  | TAS5508B Functional Structure.....   | 13 |
| 1-2  | Typical TAS5508B Application (DVD Receiver) .....  | 15 |
| 1-3  | Pass-Through Output Mixer TAS5508B Channel Configuration .....   | 16 |
| 2-1  | TAS5508B DAP Architecture With I <sup>2</sup> C Registers ( $f_s \leq 96$ kHz) .....                   | 24 |
| 2-2  | TAS5508B Architecture With I <sup>2</sup> C Registers ( $f_s = 176.4$ kHz or $f_s = 192$ kHz) .....    | 25 |
| 2-3  | TAS5508B Detailed Channel Processing .....   | 26 |
| 2-4  | 5.23 Format .....  | 27 |
| 2-5  | Conversion Weighting Factors—5.23 Format to Floating Point.....  | 27 |
| 2-6  | Alignment of 5.23 Coefficient in 32-Bit I <sup>2</sup> C Word .....                                    | 27 |
| 2-7  | 25.23 Format .....   | 28 |
| 2-8  | Conversion Weighting Factors—25.23 Format to Floating Point .....                                      | 28 |
| 2-9  | Alignment of 25.23 Coefficient in Two 32-Bit I <sup>2</sup> C Words.....                               | 29 |
| 2-10 | TAS5508B Digital Audio Processing .....  | 30 |
| 2-11 | Input Crossbar Mixer .....   | 30 |
| 2-12 | Biquad Filter Structure.....   | 31 |
| 2-13 | Automute Threshold .....   | 33 |
| 2-14 | Loudness Compensation Functional Block Diagram .....   | 34 |
| 2-15 | Loudness Example Plots .....   | 35 |
| 2-16 | DRC Positioning in TAS5508B Processing Flow .....  | 37 |
| 2-17 | Dynamic Range Compression (DRC) Transfer Function Structure .....                                      | 37 |
| 2-18 | Output Mixers.....   | 41 |
| 2-19 | De-Emphasis Filter Characteristics .....   | 42 |
| 2-20 | Power-Supply and Digital Gains (Linear Space).....   | 43 |
| 2-21 | Power-Supply and Digital Gains (Log Space).....  | 43 |
| 2-22 | Block Diagrams of Typical Systems Requiring TAS5508B Automatic AM Interference-Avoidance Circuit ..... | 44 |
| 4-1  | Slave Mode Serial Data Interface Timing .....  | 57 |
| 4-2  | Start and Stop Conditions Timing Waveforms .....   | 58 |
| 4-3  | I <sup>2</sup> C Pullup Circuit (With No Series Resistor).....   | 59 |
| 4-4  | I <sup>2</sup> C Pullup Circuit (With Series Resistor) .....   | 59 |
| 4-5  | Reset Timing.....  | 60 |
| 4-6  | Power-Down Timing .....  | 60 |
| 4-7  | Error-Recovery Timing .....  | 61 |
| 4-8  | Mute Timing.....   | 61 |
| 4-9  | HP_SEL Timing .....  | 62 |
| 4-10 | I <sup>2</sup> S 64- $f_s$ Format .....  | 63 |
| 4-11 | Left-Justified 64- $f_s$ Format .....  | 64 |
| 4-12 | Right-Justified 64- $f_s$ Format .....   | 65 |
| 5-1  | Typical I <sup>2</sup> C Sequence.....   | 66 |
| 5-2  | Single-Byte Write Transfer.....  | 67 |

---

|     |                                    |                    |
|-----|------------------------------------|--------------------|
| 5-3 | Multiple-Byte Write Transfer ..... | <a href="#">68</a> |
| 5-4 | Single-Byte Read Transfer.....     | <a href="#">69</a> |
| 5-5 | Multiple-Byte Read Transfer.....   | <a href="#">69</a> |

## List of Tables

|      |   |                    |
|------|---|--------------------|
| 1-1  | I <sup>2</sup> C Register 0xD0 Bit 30 Usage.....                            | <a href="#">14</a> |
| 2-1  | Serial Data Formats .....   | <a href="#">21</a> |
| 2-2  | TAS5508B Audio-Processing Feature Sets .....                                | <a href="#">23</a> |
| 2-3  | Contents of One 20-Byte Biquad Filter Register (Default = All-Pass).....    | <a href="#">31</a> |
| 2-4  | Bass and Treble Filter Selections .....                                     | <a href="#">32</a> |
| 2-5  | Linear Gain Step Size .....   | <a href="#">32</a> |
| 2-6  | Default Loudness Compensation Parameters.....                               | <a href="#">34</a> |
| 2-7  | Example Loudness Function Parameters.....                                   | <a href="#">35</a> |
| 2-8  | DRC Recommended Changes From TAS5508B Defaults .....                        | <a href="#">36</a> |
| 3-1  | Device Outputs During Reset .....   | <a href="#">45</a> |
| 3-2  | Values Set During Reset .....   | <a href="#">46</a> |
| 3-3  | Device Outputs During Power Down .....                                      | <a href="#">47</a> |
| 3-4  | Device Outputs During Back-End Error .....                                  | <a href="#">48</a> |
| 3-5  | Description of the Channel Configuration Registers (0x05 to 0x0C) .....     | <a href="#">49</a> |
| 3-6  | Recommended TAS5508B Configurations for Texas Instruments Power Stages..... | <a href="#">50</a> |
| 3-7  | Audio System Configuration (General Control Register 0xE0).....             | <a href="#">50</a> |
| 3-8  | Volume Ramp Periods in ms .....   | <a href="#">51</a> |
| 7-1  | Clock Control Register Format .....   | <a href="#">74</a> |
| 7-2  | General Status Register Format .....  | <a href="#">74</a> |
| 7-3  | System Control Register-1 Format .....                                      | <a href="#">74</a> |
| 7-4  | System Control Register-2 Format .....                                      | <a href="#">75</a> |
| 7-5  | Channel Configuration Control Register Format .....                         | <a href="#">75</a> |
| 7-6  | Headphone Configuration Control Register Format .....                       | <a href="#">76</a> |
| 7-7  | Serial Data Interface Control Register Format .....                         | <a href="#">76</a> |
| 7-8  | Soft Mute Register Format.....  | <a href="#">77</a> |
| 7-9  | Automute Control Register Format .....                                      | <a href="#">78</a> |
| 7-10 | Automute PWM Threshold and Back-End Reset Period Register Format .....      | <a href="#">79</a> |
| 7-11 | Modulation Index Limit Register Format .....                                | <a href="#">80</a> |
| 7-12 | Bank-Switching Command Register Format.....                                 | <a href="#">81</a> |
| 7-13 | Channel 1–8 Input Mixer Register Format.....                                | <a href="#">82</a> |
| 7-14 | Bass Management Register Format.....  | <a href="#">85</a> |
| 7-15 | Biquad Filter Register Format .....   | <a href="#">85</a> |
| 7-16 | Contents of One 20-Byte Biquad Filter Register (Default = All-Pass).....    | <a href="#">86</a> |
| 7-17 | Channel 1–8 Bass and Treble Bypass Register Format.....                     | <a href="#">86</a> |
| 7-18 | Loudness Register Format.....   | <a href="#">86</a> |
| 7-19 | Channel 1–7 DCR1 Control Register Format .....                              | <a href="#">87</a> |
| 7-20 | Channel-8 DRC2 Control Register Format .....                                | <a href="#">88</a> |
| 7-21 | DRC1 Data Register Format.....  | <a href="#">88</a> |
| 7-22 | DRC2 Data Register Format.....  | <a href="#">89</a> |



|      |  |                     |
|------|--|---------------------|
| 7-23 | DRC Bypass Register Format .....   | <a href="#">89</a>  |
| 7-24 | Output Mixer Register Format (Upper 4 Bytes) .....   | <a href="#">90</a>  |
| 7-25 | Output Mixer Register Format (Lower 4 Bytes) .....   | <a href="#">90</a>  |
| 7-26 | Output Mixer Register Format (Upper 4 Bytes) .....   | <a href="#">91</a>  |
| 7-27 | Output Mixer Register Format (Middle 4 Bytes) .....  | <a href="#">91</a>  |
| 7-28 | Output Mixer Register Format (Lower 4 Bytes) .....   | <a href="#">92</a>  |
| 7-29 | Volume Biquad Register Format (Default = All-Pass) .....   | <a href="#">92</a>  |
| 7-30 | Volume Gain Update Rate (Slew Rate) .....  | <a href="#">93</a>  |
| 7-31 | Treble and Bass Gain Step Size (Slew Rate) .....   | <a href="#">93</a>  |
| 7-32 | Volume Register Format .....   | <a href="#">93</a>  |
| 7-33 | Master and Individual Volume Controls .....  | <a href="#">94</a>  |
| 7-34 | Channel 8 (Subwoofer) .....  | <a href="#">95</a>  |
| 7-35 | Channels 6 and 5 (Right and Left Lineout in 6-Channel Configuration; Right and Left Surround in 8-Channel Configuration) ..... | <a href="#">95</a>  |
| 7-36 | Channels 4 and 3 (Right and Left Rear) .....   | <a href="#">95</a>  |
| 7-37 | Channels 7, 2, and 1 (Center, Right Front, and Left Front) .....   | <a href="#">96</a>  |
| 7-38 | Bass Filter Index Register Format .....  | <a href="#">96</a>  |
| 7-39 | Bass Filter Indexes .....  | <a href="#">96</a>  |
| 7-40 | Channel 8 (Subwoofer) .....  | <a href="#">97</a>  |
| 7-41 | Channels 6 and 5 (Right and Left Lineout in 6-Channel Configuration; Right and Left Surround in 8-Channel Configuration) ..... | <a href="#">97</a>  |
| 7-42 | Channels 4 and 3 (Right and Left Rear) .....   | <a href="#">97</a>  |
| 7-43 | Channels 7, 2, and 1 (Center, Right Front, and Left Front) .....   | <a href="#">98</a>  |
| 7-44 | Treble Filter Index Register Format .....  | <a href="#">98</a>  |
| 7-45 | Treble Filter Indexes .....  | <a href="#">98</a>  |
| 7-46 | AM Mode Register Format .....  | <a href="#">99</a>  |
| 7-47 | AM Tuned Frequency Register in BCD Mode (Lower 2 Bytes of 0xDE) .....  | <a href="#">99</a>  |
| 7-48 | AM Tuned Frequency Register in Binary Mode (Lower 2 Bytes of 0xDE) .....   | <a href="#">99</a>  |
| 7-49 | PSVC Range Register Format .....   | <a href="#">100</a> |
| 7-50 | General Control Register Format .....  | <a href="#">100</a> |

**TAS5508B**  
**8-Channel Digital Audio PWM Processor**

SLES162B–DECEMBER 2005–REVISED APRIL 2006

---

## 1 Introduction

### 1.1 Features

- **General Features**
  - Automated Operation With an Easy-to-Use Control Interface
  - I<sup>2</sup>C Serial-Control Slave Interface
  - Integrated AM Interference-Avoidance Circuitry
  - Single, 3.3-V Power Supply
  - 64-Pin TQFP Package
  - 5-V Tolerant Inputs
- **Audio Input/Output**
  - Automatic Master-Clock-Rate and Data-Sample-Rate Detection
  - Eight Serial Audio Input Channels
  - Eight PWM Audio Output Channels Configurable as Six Channels With Stereo Lineout or Eight Channels
  - Line Output Is a PWM Output to Drive an External Differential-Input Operational Amplifier
  - Headphone PWM Output to Drive an External Differential Amplifier Like the TPA112
  - PWM Outputs Support Single-Ended and Bridge-Tied Loads
  - 32-, 38-, 44.1-, 48-, 88.2-, 96-, 176.4-, and 192-kHz Sampling Rates
  - Data Formats: 16-, 20-, or 24-Bit Left-Justified, I<sup>2</sup>S, or Right-Justified Input Data
  - 64-f<sub>S</sub> Bit-Clock Rate
  - 128-, 192-, 256-, 384-, 512-, and 768-f<sub>S</sub> Master Clock Rates (Up to a Maximum of 50 MHz)
- **Audio Processing**
  - 48-Bit Processing Architecture With 76 Bits of Precision for Most Audio-Processing Features
  - Volume Control Range 36 dB to –109 dB
    - Master Volume Control Range of 18 dB to –109 dB
    - Eight Individual Channel Volume Control Ranges of 18 dB to –109 dB
  - Programmable Soft Volume and Mute Update Rates
  - Four Bass and Treble Tone Controls With ±18-dB Range, Selectable Corner Frequencies, and Second-Order Slopes
    - L, R, and C
    - LS, RS
    - LR, RR
    - Sub
  - Configurable Loudness Compensation
  - Two Dynamic Range Compressors With Two Thresholds, Two Offsets, and Three Slopes
  - Seven Biquads Per Channel
  - Full 8×8 Input Crossbar Mixer. Each Signal-Processing Channel Input Can Be Any Ratio of the Eight Input Channels.
  - 8×2 Output Mixer, Channels 1–6. Each Output Is a Mix of Any Two Signal-Processed Channels. It Is Recommended to Use the Pass-Through output Mixer Configuration.
  - 8×3 Output Mixer, Channels 7 and 8. Each Output Is a Mix of Any Three Signal-Processed Channels. It Is Recommended to Use the Pass-Through output Mixer Configuration.
  - Three Coefficient Sets Stored on the Device Can Be Selected Manually or Automatically (Based on Specific Data Rates).
  - DC Blocking Filters
  - Able to Support a Variety of Bass Management Algorithms



Please be aware that an important notice concerning availability, standard warranty, and use in critical applications of Texas Instruments semiconductor products and disclaimers thereto appears at the end of this document.

Matlab is a trademark of Math Works, Inc.

- **PWM Processing**
  - **32-Bit Processing PWM Architecture With 40 Bits of Precision**
  - **8× Oversampling With Fifth-Order Noise Shaping at 32 kHz–48 kHz, 4× Oversampling at 88.2 kHz and 96 kHz, and 2× Oversampling at 176.4 kHz and 192 kHz**
  - **>102-dB Dynamic Range**
  - **THD+N < 0.1%**
  - **20-Hz–20-kHz, Flat Noise Floor for 44.1-, 48-, 88.2-, 96-, 176.4-, and 192-kHz Data Rates**
  - **Digital De-Emphasis for 32-, 44.1-, and 48-kHz Data Rates**
  - **Flexible Automute Logic With Programmable Threshold and Duration for Noise-Free Operation**
  - **Intelligent AM Interference-Avoidance System Provides Clear AM Reception**
  - **Power-Supply Volume Control (PSVC) Support for Enhanced Dynamic Range in High-Performance Applications**
  - **Adjustable Modulation Limit**

## 1.2 Overview

The TAS5508B is an 8-channel digital pulse-width modulator (PWM) that provides both advanced performance and a high level of system integration. The TAS5508B is designed to interface seamlessly with most audio digital signal processors. The TAS5508B automatically adjusts control configurations in response to clock and data rate changes and idle conditions. This enables the TAS5508B to provide an easy-to-use control interface with relaxed timing requirements.

The TAS5508B can drive eight channels of H-bridge power stages. Texas Instruments power stage parts TAS5111, TAS5112, or TAS5182 with FETs are designed to work seamlessly with the TAS5508B. The TAS5508B supports either the single-ended or bridge-tied-load configuration. The TAS5508B also provides a high-performance, differential output to drive an external, differential-input, analog headphone amplifier (such as the TPA112).

The TAS5508B uses AD modulation operating at a 384-kHz switching rate for 48-, 96-, and 192-kHz data. The 8× oversampling combined with the fifth-order noise shaper provides a broad, flat noise floor and excellent dynamic range from 20 Hz to 20 kHz.

The TAS5508B is a clocked slave-only device. The TAS5508B receives MCLK, SCLK, and LRCLK from other system components. The TAS5508B accepts master clock rates of 128, 192, 256, 384, 512, and 768  $f_s$ . The TAS5508B accepts a 64- $f_s$  bit clock.

The TAS5508B allows for extending the dynamic range by providing a power-supply, volume-control (PSVC) output signal.

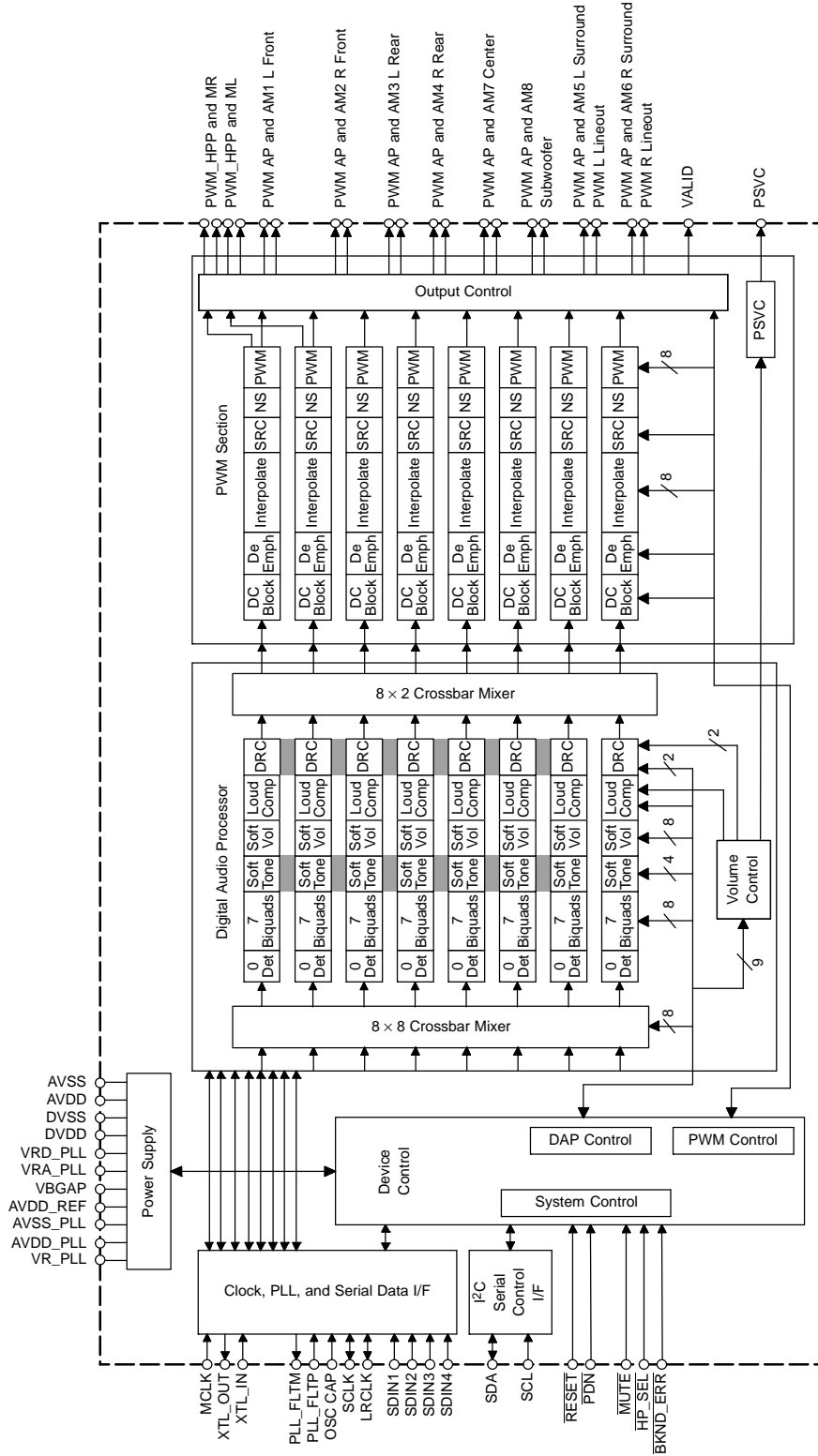

B0011-01

Figure 1-1. TAS5508B Functional Structure

### 1.3 Changes From the TAS5508A to the TAS5508B

- High-pass filter is enabled by default (0x03 bit 7)
- I<sup>2</sup>C register 0xD0 bit 30 is added in TAS5508B to support remapped output mixer configuration. It has a default value of 0.

**Table 1-1. I<sup>2</sup>C Register 0xD0 Bit 30 Usage**

| 0xD0 Bit 30 | Output Mixer Configuration | Mode  | PWM (Speaker) Operation   | Headphone operation   |
|-------------|----------------------------|---|---|---|
| 1           | Pass-through               | 8-channel mode or 6-channel mode (2 channels become lineouts) | Normal operation  | Normal operation  |
| 0 (default) | Remapped                   | 8-channel mode  | Constraints are placed in setting the combined volume below –109 dB and in using individual channel mute. | Normal Operation  |
|             |                            | 6-channel mode (2 channels become lineouts)                   | Constraints are placed in setting the combined volume below –109 dB and in using individual channel mute. | Following the assertion or de-assertion of headphone, mute must be asserted and de-asserted using the MUTE pin. |

The pass-through output mixer configuration means that each DAP channel is mapped to the same output PWM channel. For example, DAP channel 1 is routed to PWM channel 1, etc.

The remapped output mixer configuration means that the PWM channel could be a mix or rerouting of the DAP channels. For example, DAP channel 2 is routed to PWM channel 1. This remapping causes some complications in operation (see [Table 1-1](#)).

The TAS5508 recommended initialization sequence to use the pass-through output mixer configuration follows.

1. After TAS5508B reset, the default master volume is muted. It must be updated with a nonmute value for the system to start.
2. I<sup>2</sup>C register 0xD0 bit 30 must be set to a value of 1.

**Note that for best results, the pass-through output mixer configuration is recommended (0xD0 Bit 30 = 1).**

When remapping or mixing DAP channels to different PWM output channels (remapped output mixer configuration) consider the following limitations:

- Individual channel mute should not be used.
- The sum of the minimum channel volume and master volume should not be below –109 dB.
- 0xD0 bit 30 = 0

### 1.4 TAS5508B System Diagrams

Typical applications for the TAS5508B are 6- to 8-channel audio systems such as DVD or AV receivers. Figure 1-2 shows the basic system diagram of the DVD receiver.

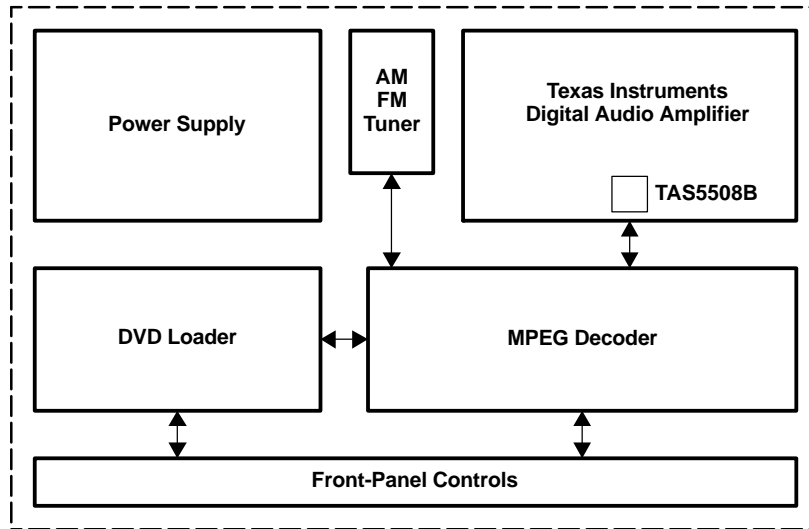

B0012-03

**Figure 1-2. Typical TAS5508B Application (DVD Receiver)**

Figure 1-3 shows the pass-through output mixer channel configuration when using the TAS5508B.

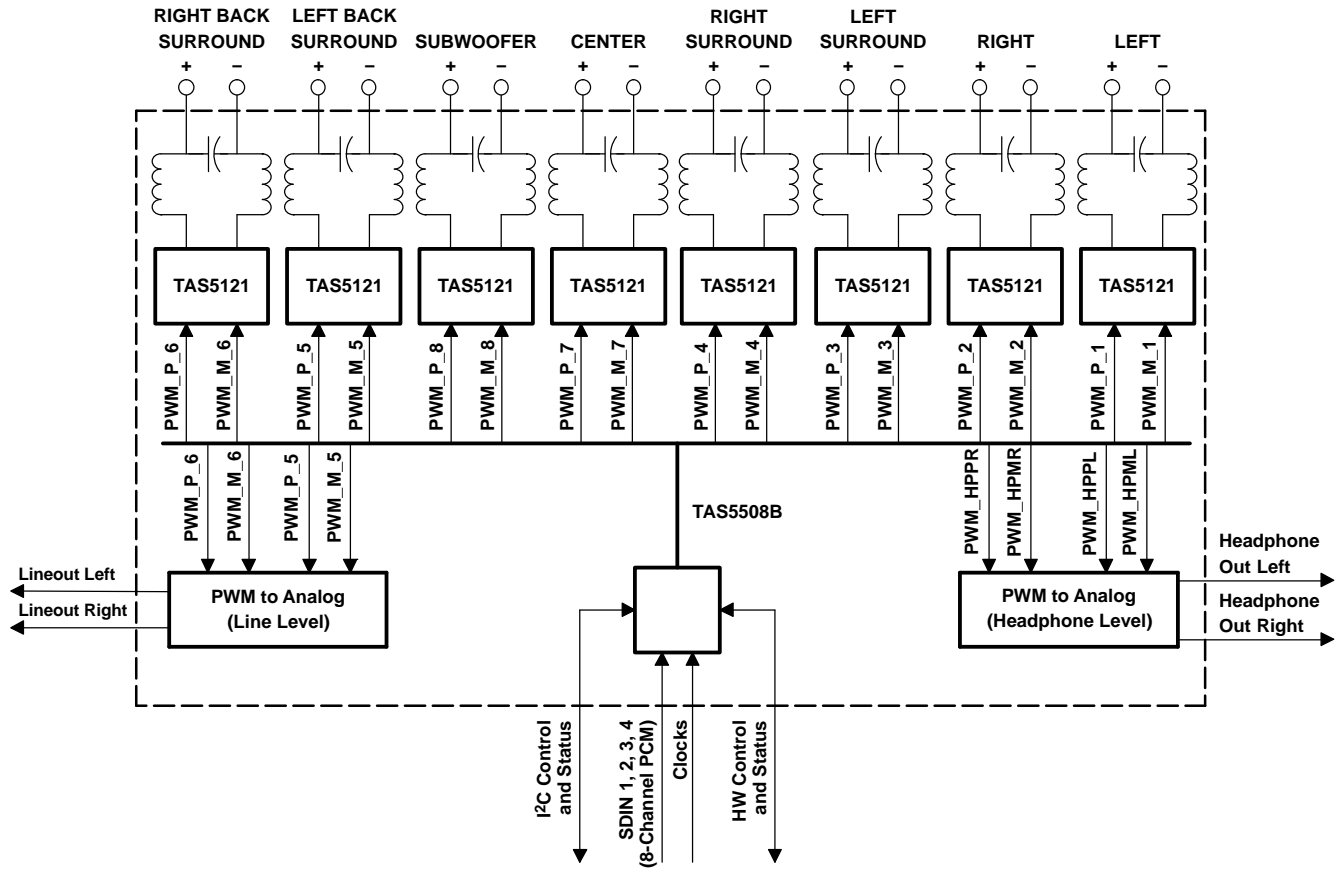

B0013-03

Figure 1-3. Pass-Through Output Mixer TAS5508B Channel Configuration



## 2 Description

### 2.1 Physical Characteristics

#### 2.1.1 Terminal Assignments

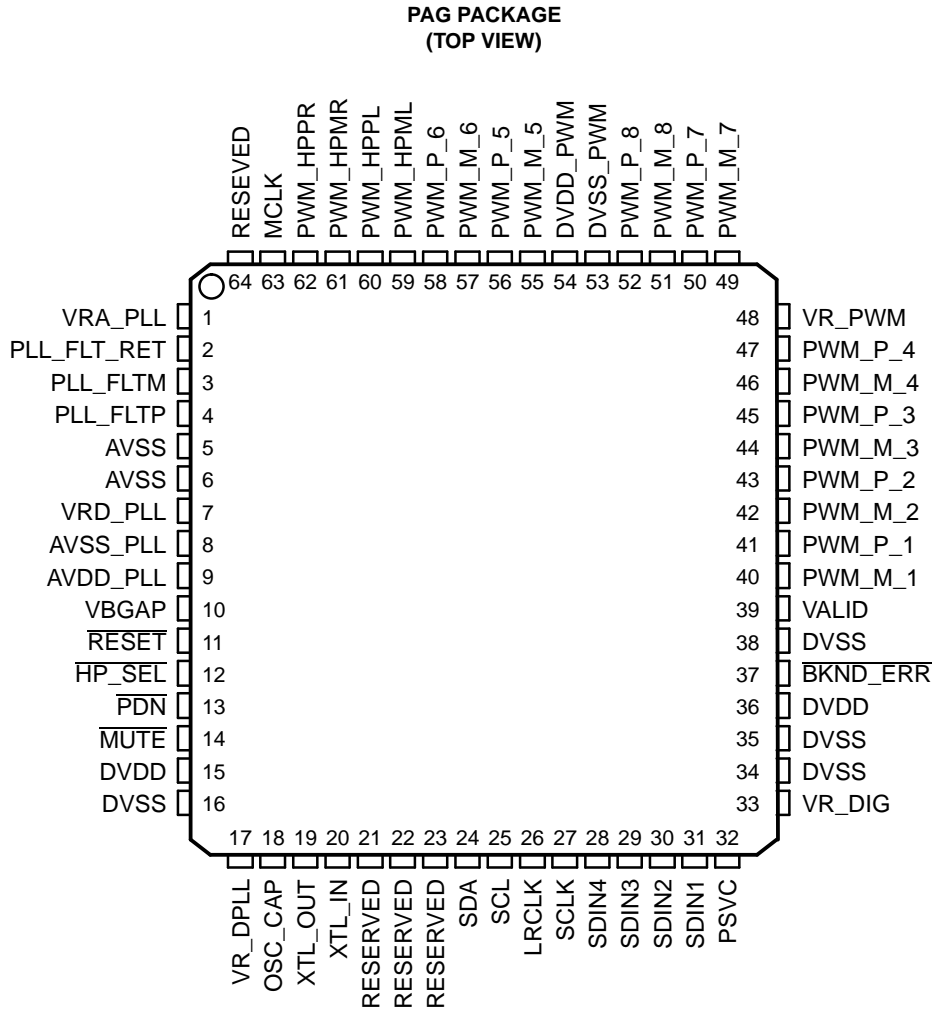

P0010-01

#### 2.1.2 Ordering Information

|             |                                  |
|-------------|----------------------------------|
| $T_A$       | <b>PLASTIC 64-PIN PQFP (P/N)</b> |
| 0°C to 70°C | TAS5508BPAG                      |

### 2.1.3 Terminal Descriptions

| TERMINAL    |                | TYPE <sup>(1)</sup> | 5-V TOLERANT | TERMINATION <sup>(2)</sup> | DESCRIPTION   |
|-------------|----------------|---------------------|--------------|----------------------------|---|
| NAME        | NO.            |                     |              |                            |   |
| AVDD_PLL    | 9              | P                   |              |                            | 3.3-V analog power supply for PLL. This terminal can be connected to the same power source used to drive power terminal DVDD; but to achieve low PLL jitter, this terminal should be bypassed to AVSS_PLL with a 0.1- $\mu$ F low-ESR capacitor.  |
| AVSS        | 5, 6           | P                   |              |                            | Analog ground   |
| AVSS_PLL    | 8              | P                   |              |                            | Analog ground for PLL. This terminal should reference the same ground as terminal DVSS; but to achieve low PLL jitter, ground noise at this terminal must be minimized. The availability of the AVSS terminal allows a designer to use optimizing techniques such as star ground connections, separate ground planes, or other quiet ground-distribution techniques to achieve a quiet ground reference at this terminal. |
| BKND_ERR    | 37             | DI                  |              | Pullup                     | Active-low. A back-end error sequence is generated by applying logic low to this terminal. The BKND_ERR results in no change to any system parameters, with all H-bridge drive signals going to a hard-mute state (M-state).  |
| DVDD        | 15, 36         | P                   |              |                            | 3.3-V digital power supply. It is recommended that decoupling capacitors of 0.1 $\mu$ F and 10 $\mu$ F be mounted close to this pin (see application schematics).   |
| DVDD_PWM    | 54             | P                   |              |                            | 3.3-V digital power supply for PWM  |
| DVSS        | 16, 34, 35, 38 | P                   |              |                            | Digital ground  |
| DVSS_PWM    | 53             | P                   |              |                            | Digital ground for PWM  |
| HP_SEL      | 12             | DI                  | 5 V          | Pullup                     | Headphone in/out selector. When a logic low is applied, the headphone is selected (speakers are off). When a logic high is applied, speakers are selected (headphone is off).   |
| LRCLK       | 26             | DI                  | 5 V          |                            | Serial-audio data left/right clock (sampling-rate clock)  |
| MCLK        | 63             | DI                  | 5 V          | Pulldown                   | MCLK is a 3.3-V master clock input. The input frequency of this clock can range from 4 MHz to 50 MHz.   |
| MUTE        | 14             | DI                  | 5 V          | Pullup                     | Soft mute of outputs, active-low (muted signal = a logic low, normal operation = a logic high). The mute control provides a noiseless volume ramp to silence. Releasing mute provides a noiseless ramp to previous volume.  |
| OSC_CAP     | 18             | AO                  |              |                            | Oscillator capacitor  |
| PDN         | 13             | DI                  | 5 V          | Pullup                     | Power down, active-low. PDN powers down all logic and stops all clocks whenever a logic low is applied. The internal parameters are preserved through a power-down cycle, as long as RESET is not active. The duration for system recovery from power down is 100 ms.   |
| PLL_FLT_RET | 2              | AO                  |              |                            | PLL external filter return  |
| PLL_FLTM    | 3              | AO                  |              |                            | PLL negative input. Connected to PLL_FLT_RET via an RC network  |
| PLL_FLTP    | 4              | AI                  |              |                            | PLL positive input. Connected to PLL_FLT_RET via an RC network  |
| PSVC        | 32             | O                   |              |                            | Power-supply volume control PWM output  |
| PWM_HPML    | 59             | DO                  |              |                            | PWM left-channel headphone (differential –)   |
| PWM_HPMR    | 61             | DO                  |              |                            | PWM right-channel headphone (differential –)  |
| PWM_HPPL    | 60             | DO                  |              |                            | PWM left-channel headphone (differential +)   |
| PWM_HPPR    | 62             | DO                  |              |                            | PWM right-channel headphone (differential +)  |
| PWM_M_1     | 40             | DO                  |              |                            | PWM 1 output (differential –)   |
| PWM_M_2     | 42             | DO                  |              |                            | PWM 2 output (differential –)   |
| PWM_M_3     | 44             | DO                  |              |                            | PWM 3 output (differential –)   |
| PWM_M_4     | 46             | DO                  |              |                            | PWM 4 output (differential –)   |
| PWM_M_5     | 55             | DO                  |              |                            | PWM 5 output (lineout L) (differential –)   |
| PWM_M_6     | 57             | DO                  |              |                            | PWM 6 output (lineout R) (differential –)   |
| PWM_M_7     | 49             | DO                  |              |                            | PWM 7 output (differential –)   |
| PWM_M_8     | 51             | DO                  |              |                            | PWM 8 output (differential –)   |
| PWM_P_1     | 41             | DO                  |              |                            | PWM 1 output (differential +)   |
| PWM_P_2     | 43             | DO                  |              |                            | PWM 2 output (differential +)   |
| PWM_P_3     | 45             | DO                  |              |                            | PWM 3 output (differential +)   |

(1) Type: A = analog; D = 3.3-V digital; P = power/ground/decoupling; I = input; O = output

(2) All pullups are 20- $\mu$ A weak pullups and all pulldowns are 20- $\mu$ A weak pulldowns. The pullups and pulldowns are included to ensure proper input logic levels if the terminals are left unconnected (pullups  $\rightarrow$  logic-1 input; pulldowns  $\rightarrow$  logic-0 input). Devices that drive inputs with pullups must be able to sink 20  $\mu$ A while maintaining a logic-0 drive level. Devices that drive inputs with pulldowns must be able to source 20  $\mu$ A while maintaining a logic-1 drive level.

| TERMINAL |                   | TYPE <sup>(1)</sup> | 5-V<br>TOLERANT | TERMINATION <sup>(2)</sup> | DESCRIPTION  |
|----------|-------------------|---------------------|-----------------|----------------------------|--|
| NAME     | NO.               |                     |                 |                            |  |
| PWM_P_4  | 47                | DO                  |                 |                            | PWM 4 output (differential +)  |
| PWM_P_5  | 56                | DO                  |                 |                            | PWM 5 output (lineout L) (differential +)  |
| PWM_P_6  | 58                | DO                  |                 |                            | PWM 6 output (lineout R) (differential +)  |
| PWM_P_7  | 50                | DO                  |                 |                            | PWM 7 output (differential +)  |
| PWM_P_8  | 52                | DO                  |                 |                            | PWM 8 output (differential +)  |
| RESERVED | 21, 22,<br>23, 64 |                     |                 |                            | Connect to digital ground  |
| RESET    | 11                | DI                  | 5 V             | Pullup                     | System reset input, active-low. A system reset is generated by applying a logic low to this terminal. RESET is an asynchronous control signal that restores the TAS5508B to its default conditions, sets the valid output low, and places the PWM in the hard-mute state (M-state). Master volume is immediately set to full attenuation. On the release of RESET, if PDN is high, the system performs a 4- to 5-ms device initialization and sets the volume at mute. |
| SCL      | 25                | DI                  | 5 V             |                            | I <sup>2</sup> C serial-control clock input/output   |
| SCLK     | 27                | DI                  | 5 V             |                            | Serial-audio data clock (shift clock) input  |
| SDA      | 24                | DIO                 | 5 V             |                            | I <sup>2</sup> C serial-control data-interface input/output  |
| SDIN1    | 31                | DI                  | 5 V             | Pulldown                   | Serial-audio data input 1 is one of the serial-data input ports. SDIN1 supports four discrete (stereo) data formats and is capable of inputting data at 64 f <sub>s</sub> .  |
| SDIN2    | 30                | DI                  | 5 V             | Pulldown                   | Serial-audio data input 2 is one of the serial-data input ports. SDIN2 supports four discrete (stereo) data formats and is capable of inputting data at 64 f <sub>s</sub> .  |
| SDIN3    | 29                | DI                  | 5 V             | Pulldown                   | Serial-audio data input 3 is one of the serial-data input ports. SDIN3 supports four discrete (stereo) data formats and is capable of inputting data at 64 f <sub>s</sub> .  |
| SDIN4    | 28                | DI                  | 5 V             | Pulldown                   | Serial-audio data input 4 is one of the serial-data input ports. SDIN4 supports four discrete (stereo) data formats and is capable of inputting data at 64 f <sub>s</sub> .  |
| VALID    | 39                | DO                  |                 |                            | Output indicating validity of PWM outputs, active-high   |
| VBGAP    | 10                | P                   |                 |                            | Band-gap voltage reference. A pinout of the internally regulated 1.2-V reference. Typically has a 1-nF low-ESR capacitor between VBGAP and AVSS_PLL. This terminal must not be used to power external devices.   |
| VR_DIG   | 33                | P                   |                 |                            | Voltage reference for 1.8-V digital core supply. A pinout of the internally regulated 1.8-V power used by digital core logic. A 4.7-μF low-ESR capacitor <sup>(3)</sup> should be connected between this terminal and DVSS. This terminal must not be used to power external devices.  |
| VR_DPLL  | 17                | P                   |                 |                            | Voltage reference for 1.8-V digital PLL supply. A pinout of the internally regulated 1.8-V power used by digital PLL logic. A 0.1-μF low-ESR capacitor <sup>(3)</sup> should be connected between this terminal and DVSS_CORE. This terminal must not be used to power external devices.   |
| VR_PWM   | 48                | P                   |                 |                            | Voltage reference for 1.8-V digital PWM core supply. A pinout of the internally regulated 1.8-V power used by digital PWM core logic. A 0.1-μF low-ESR capacitor <sup>(3)</sup> should be connected between this terminal and DVSS_PWM. This terminal must not be used to power external devices.  |
| VRA_PLL  | 1                 | P                   |                 |                            | Voltage reference for 1.8-V PLL analog supply. A pinout of the internally regulated 1.8-V power used by PLL logic. A 0.1-μF low-ESR capacitor <sup>(3)</sup> should be connected between this terminal and AVSS_PLL. This terminal must not be used to power external devices.   |
| VRD_PLL  | 7                 | P                   |                 |                            | Voltage reference for 1.8-V PLL digital supply. A pinout of the internally regulated 1.8-V power used by PLL logic. A 0.1-μF low-ESR capacitor <sup>(3)</sup> should be connected between this terminal and AVSS_PLL. This terminal must not be used to power external devices.  |
| XTL_IN   | 20                | AI                  |                 |                            | XTL_OUT and XTL_IN are the only LVCMOS terminals on the device. They provide a reference clock for the TAS5508B via use of an external fundamental-mode crystal. XTL_IN is the 1.8-V input port for the oscillator circuit. A 13.5-MHz crystal (HCM49) is recommended.   |
| XTL_OUT  | 19                | AO                  |                 |                            | XTL_OUT and XTL_IN are the only LVCMOS terminals on the device. They provide a reference clock for the TAS5508B via use of an external fundamental-mode crystal. XTL_OUT is the 1.8-V output drive to the crystal. A 13.5-MHz crystal (HCM49) is recommended.  |

(3) If desired, low-ESR capacitance values can be implemented by paralleling two or more ceramic capacitors of equal value. Paralleling capacitors of equal value provides an extended high-frequency supply decoupling. This approach avoids the potential of producing parallel resonance circuits that have been observed when paralleling capacitors of different values.

## 2.2 TAS5508B Functional Description

Figure 1-1 shows the TAS5508B functional structure. The following sections describe the TAS5508B functional blocks:

- Power supply
- Clock, PLL, and serial data interface
- I<sup>2</sup>C serial-control interface
- Device control
- Digital audio processor (DAP)

### 2.2.1 Power Supply

The power-supply section contains supply regulators that provide analog and digital regulated power for various sections of the TAS5508B. The analog supply supports the analog PLL, whereas digital supplies support the digital PLL, the digital audio processor (DAP), the pulse-width modulator (PWM), and the output control.

### 2.2.2 Clock, PLL, and Serial Data Interface

The TAS5508B is a clocked slave-only device that requires the use of an external 13.5-MHz crystal. It accepts MCLK, SCLK, and LRCLK as inputs only.

The TAS5508B uses the external crystal to provide a time base for:

- Continuous data and clock error detection and management
- Automatic data-rate detection and configuration
- Automatic MCLK-rate detection and configuration (automatic bank switching)
- Supporting I<sup>2</sup>C operation/communication while MCLK is absent

The TAS5508B automatically handles clock errors, data-rate changes, and master-clock frequency changes without requiring intervention from an external system controller. This feature significantly reduces system complexity and design.

#### 2.2.2.1 Serial Audio Interface

The TAS5508B operates as a slave-only/receive-only serial data interface in all modes. The TAS5508B has four PCM serial data interfaces to permit eight channels of digital data to be received through the SDIN1, SDIN2, SDIN3, and SDIN4 inputs. The serial audio data is in MSB-first, 2s-complement format.

The serial data input interface of the TAS5508B can be configured in right-justified, I<sup>2</sup>S, or left-justified modes. The serial data interface format is specified using the I<sup>2</sup>C data-interface control register. The supported formats and word lengths are shown in Table 2-1.

**Table 2-1. Serial Data Formats**

| RECEIVE SERIAL DATA FORMAT | WORD LENGTH |
|----------------------------|-------------|
| Right-justified            | 16          |
| Right-justified            | 20          |
| Right-justified            | 24          |
| I <sup>2</sup> S           | 16          |
| I <sup>2</sup> S           | 20          |
| I <sup>2</sup> S           | 24          |
| Left-justified             | 16          |
| Left-justified             | 20          |
| Left-justified             | 24          |

Serial data is input on SDIN1, SDIN2, SDIN3, and SDIN4. The TAS5508B accepts 16-, 20-, or 24-bit serial data at 32, 38, 44.1, 48, 88.2, 96, 176.4, or 192 kHz in left-justified, I<sup>2</sup>S, or right-justified format. Data is input using a 64-f<sub>S</sub> SCLK clock and an MCLK rate of 128, 192, 256, 384, 512, or 768 f<sub>S</sub>, up to a maximum of 50 MHz. The clock speed and serial data format are I<sup>2</sup>C configurable.

### 2.2.3 I<sup>2</sup>C Serial-Control Interface

The TAS5508B has an I<sup>2</sup>C serial-control slave interface (write address = 0x36 and read address = 0x37) to receive commands from a system controller. The serial-control interface supports both normal-speed (100-kHz) and high-speed (400-kHz) operations without wait states. Because the TAS5508B has a crystal time base, this interface operates even when MCLK is absent.

The serial control interface supports both single-byte and multiple-byte read/write operations for status registers and the general control registers associated with the PWM. However, for the DAP data-processing registers, the serial control interface also supports multiple-byte (4-byte) write operations.

The I<sup>2</sup>C supports a special mode which permits I<sup>2</sup>C write operations to be broken up into multiple data-write operations that are multiples of 4 data bytes. These are 6-byte, 10-byte, 14-byte, 18-byte, etc., write operations that are composed of a device address, read/write bit, subaddress, and any multiple of 4 bytes of data. This permits the system to incrementally write large register values without blocking other I<sup>2</sup>C transactions. In order to use this feature, the first block of data is written to the target I<sup>2</sup>C address, and each subsequent block of data is written to a special append register (0xFE) until all the data is written and a stop bit is sent. An incremental read operation is not supported.

### 2.2.4 Device Control

The TAS5508B control section provides the control and sequencing for the TAS5508B. The device control provides both high- and low-level control for the serial control interface, clock and serial data interfaces, digital audio processor, and pulse-width modulator sections.

### 2.2.5 Digital Audio Processor (DAP)

The DAP arithmetic unit is used to implement all audio-processing functions: soft volume, loudness compensation, bass and treble processing, dynamic range control, channel filtering, and input and output mixing. [Figure 2-1](#) shows the TAS5508B DAP architecture.

The DAP accepts 24-bit data from the serial data interface and outputs 32-bit data to the PWM section. The DAP supports two configurations, one for 32-kHz to 96-kHz data and one for 176.4-kHz to 192-kHz data.

### 2.2.5.1 TAS5508B Audio-Processing Configurations

The 32-kHz to 96-kHz configuration supports eight channels of data processing that can be configured either as eight channels, or as six channels with two channels for separate stereo line outputs.

The 176.4-kHz to 192-kHz configuration supports three channels of signal processing with five channels passed through (or derived from the three processed channels).

To support efficiently the processing requirements of both multichannel 32-kHz to 96-kHz data and the 2-channel 176.4-kHz and 192-kHz data, the TAS5508B has separate audio-processing features for 32-kHz to 96-kHz data rates and for 176.4 kHz and 192 kHz. See [Table 2-2](#) for a summary of TAS5508B processing feature sets.

### 2.2.5.2 TAS5508B Audio Signal-Processing Functions

The DAP provides 10 primary signal-processing functions:

- The data-processing input has a full 8×8 input crossbar mixer. This enables each input to be any mix of the eight input channels.
- Two I<sup>2</sup>C programmable threshold detectors in each channel support automute.
- Seven biquads per channel
- Four soft bass and treble tone controls with ±18-dB range, programmable corner frequencies, and second-order slopes. In 8-channel mode, bass and treble controls are normally configured as follows:
  - Bass and treble 1: Channel 1 (left), channel 2 (right), and channel 7 (center)
  - Bass and treble 2: Channel 3 (left surround) and channel 4 (right surround)
  - Bass and treble 3: Channel 5 (left back surround) and channel 6 (right back surround)
  - Bass and treble 4: Channel 8 (subwoofer)
- Individual channel and master volume controls. Each control provides an adjustment range of 18 dB to –109 dB plus mute. This permits a total volume device control range of 36 dB to –109 dB plus mute. The master volume control can be configured to control six or eight channels. The DAP soft volume and mute update interval is I<sup>2</sup>C programmable. The update is performed at a fixed rate regardless of the sample rate.
- Programmable loudness compensation that is controlled via the combination of the master and individual volume settings.
- Two dual-threshold, dual-rate, dynamic range compressors (DRCs). The volume gain values provided are used as input parameters using the maximum RMS (master volume × individual channel volume).
- 8×2 output mixer (channels 1–6). Each output is a mix of any two signal-processed channels. It is recommended to use the pass-through output mixer configuration.
- 8×3 output mixer (channels 7 and 8). Each output is a mix of any three signal-processed channels. It is recommended to use the pass-through output mixer configuration.
- The DAP maintains three sets of coefficient banks that are used to maintain separate sets of sample-rate-dependent parameters for the biquad, tone controls, loudness, and DRC in RAM. These can be set to be automatically selected for one or more data sample rates or can be manually selected under I<sup>2</sup>C program control. This feature enables coefficients for different sample rates to be stored in the TAS5508B and then selected when needed.

**Table 2-2. TAS5508B Audio-Processing Feature Sets**

| FEATURE  | 32 kHz–96 kHz<br>8-CHANNEL FEATURE SET   | 32 kHz–96 kHz<br>6 + 2 LINEOUT FEATURE SET   | 176.4- and 192-kHz<br>FEATURE SET  |
|--|--|--|--|
| Signal-processing channels                       | 8  | 6 + 2  | 3  |
| Pass-through channels                            | N/A  |  | 5  |
| Master volume                                    | 1 for 8 channels   | 1 for 6 channels   | 1 for 8 channels   |
| Individual channel volume controls               | 8  |  | 8  |
| Bass and treble tone controls                    | Four bass and treble tone controls with $\pm 18$ -dB range, programmable corner frequencies, and second-order slopes<br>L, R, and C (Ch1, 2, and 7)<br>LS, RS (Ch3 and 4)<br>LBS, RBS (Ch5 and 6)<br>Sub (Ch8) | Four bass and treble tone controls with $\pm 18$ -dB range, programmable corner frequencies, and second-order slopes<br>L, R, and C (Ch1, 2, and 7)<br>LS, RS (Ch3 and 4)<br>Sub (Ch8)<br>Line L and R (Ch5 and 6) | Two bass and treble tone controls with $\pm 18$ -dB range, programmable corner frequencies, and second-order slopes<br>L and R (Ch1 and 2)<br>Sub (Ch8)  |
| Biquads  | 56   |  | 21   |
| Dynamic range compressors                        | DRC1 for seven satellites and DRC2 for sub   | DRC1 for five satellites and DRC2 for sub (Ch5 and 6 uncompressed)   | DRC1 for two satellites and DRC2 for sub   |
| Input/output mapping/mixing                      | Each of the eight signal-processing channel inputs can be any mix of the eight input channels.<br>Each of the eight outputs can be any mix of any two processed channels.                                      |  | Each of the three signal-processing channels or the five pass-through channel inputs can be any mix of the eight input channels.<br>Each of the eight outputs can be any mix of any of the three processed channels or five bypass channels. |
| DC-blocking filters (implemented in PWM section) | Eight channels   |  |  |
| Digital de-emphasis (implemented in PWM section) | Eight channels for 32 kHz, 44.1 kHz, and 48 kHz  | Six channels for 32 kHz, 44.1 kHz, and 48 kHz  | N/A  |
| Loudness   | Eight channels   | Six channels   | Three channels   |
| Number of coefficient sets stored                | Three additional coefficient sets can be stored in memory.   |  |  |

## 2.3 TAS5508B DAP Architecture

### 2.3.1 TAS5508B DAP Architecture Diagrams

Figure 2-1 shows the TAS5508B DAP architecture for  $f_s \leq 96$  kHz. Note the TAS5508B bass management architecture shown in channels 1, 2, 7, and 8. Note that the I<sup>2</sup>C registers are shown to help the designer configure the TAS5508B.

Figure 2-2 shows the TAS5508B architecture for  $f_s = 176.4$  kHz or  $f_s = 192$  kHz. Note that only channels 1, 2, and 8 contain all the features. Channels 3–7 are pass-through except for volume controls.

Figure 2-3 shows TAS5508B detailed channel processing. The output mixer is 8×2 for channels 1–6 and 8×3 for channels 7 and 8.

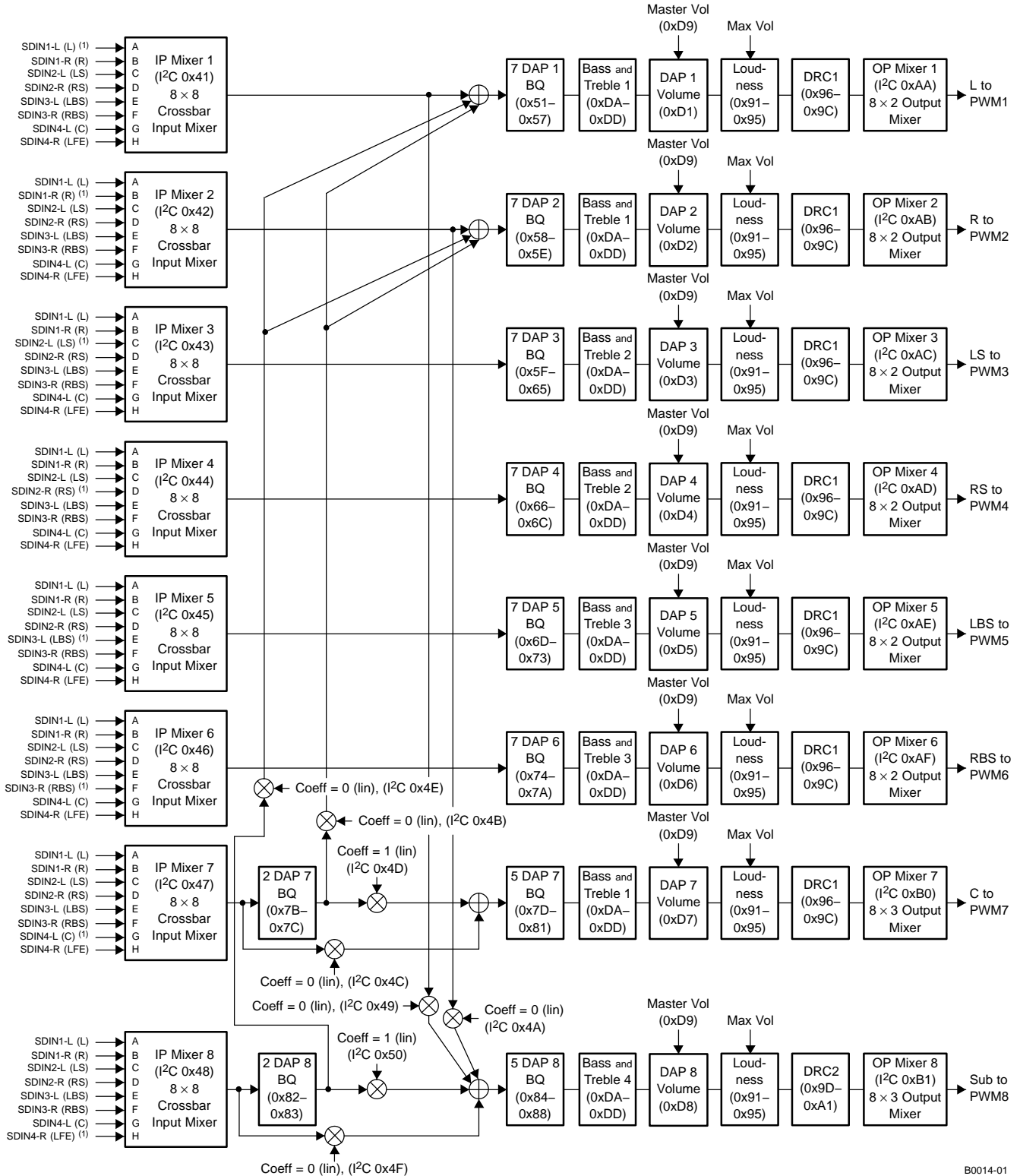

B0014-01

(1) Default inputs

**Figure 2-1. TAS5508B DAP Architecture With I<sup>2</sup>C Registers ( $f_s \leq 96$  kHz)**



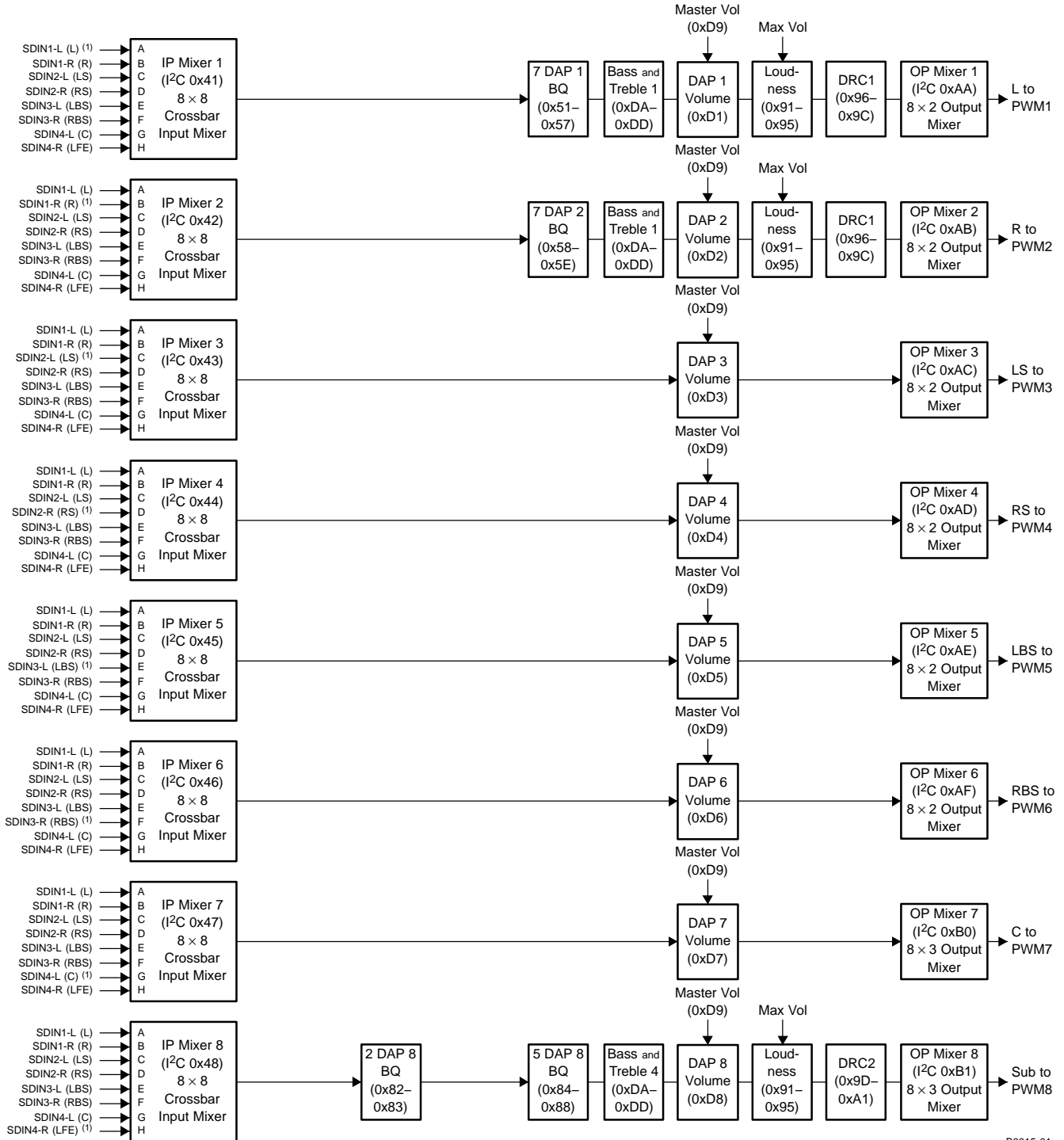

B0015-01

(1) Default inputs

**Figure 2-2. TAS5508B Architecture With I<sup>2</sup>C Registers ( $f_s = 176.4$  kHz or  $f_s = 192$  kHz)**

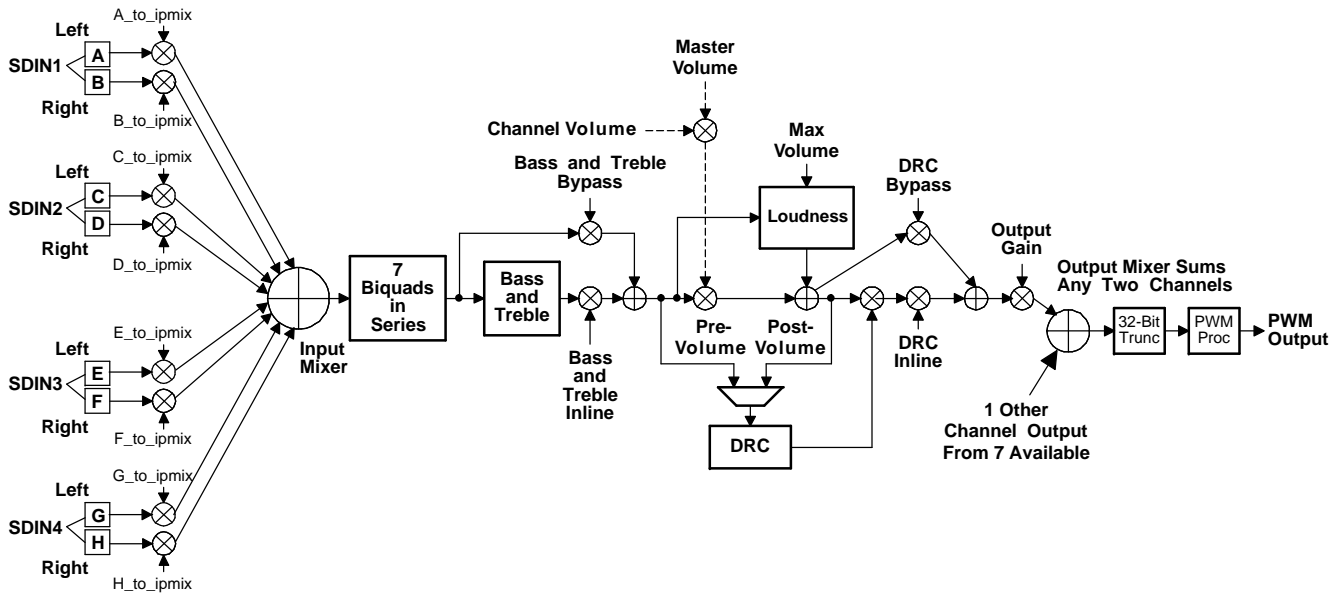

B0016-01

Figure 2-3. TAS5508B Detailed Channel Processing

### 2.3.2 I<sup>2</sup>C Coefficient Number Formats

The architecture of the TAS5508B is contained in ROM resources within the TAS5508B and cannot be altered. However, mixer gain, level offset, and filter tap coefficients, which can be entered via the I<sup>2</sup>C bus interface, provide a user with the flexibility to set the TAS5508B to a configuration that achieves system-level goals.

The firmware is executed in a 48-bit, signed, fixed-point arithmetic machine. The most significant bit of the 48-bit data path is a sign bit, and the 47 lower bits are data bits. Mixer gain operations are implemented by multiplying a 48-bit, signed data value by a 28-bit, signed gain coefficient. The 76-bit, signed output product is then truncated to a signed, 48-bit number. Level offset operations are implemented by adding a 48-bit, signed offset coefficient to a 48-bit, signed data value. In most cases, if the addition results in overflowing the 48-bit, signed number format, saturation logic is used. This means that if the summation results in a positive number that is greater than 0x7FFF FFFF FFFF (the spaces are used to ease the reading of the hexadecimal number), the number is set to 0x7FFF FFFF FFFF. If the summation results in a negative number that is less than 0x8000 0000 0000, the number is set to 0x8000 0000 0000.

#### 2.3.2.1 28-Bit 5.23 Number Format

All mixer gain coefficients are 28-bit coefficients using a 5.23 number format. Numbers formatted as 5.23 numbers have 5 bits to the left of the binary point and 23 bits to the right of the binary point. This is shown in [Figure 2-4](#).

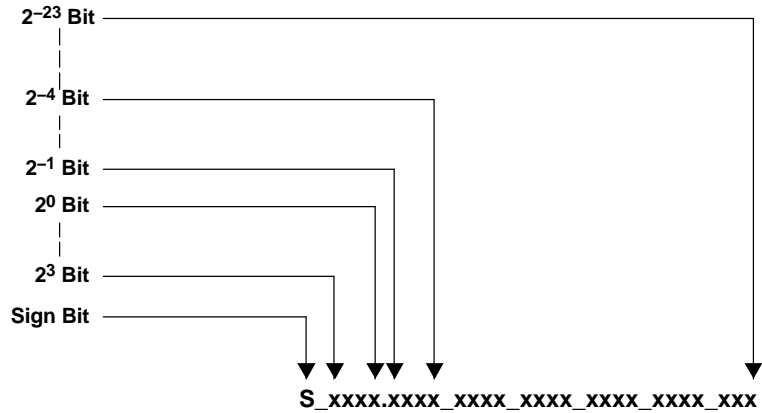

M0007-01

Figure 2-4. 5.23 Format

The decimal value of a 5.23 format number can be found by following the weighting shown in Figure 2-5. If the most significant bit is logic 0, the number is a positive number, and the weighting shown yields the correct number. If the most significant bit is a logic 1, then the number is a negative number. In this case, every bit must be inverted, a 1 added to the result, and then the weighting shown in Figure 2-5 applied to obtain the magnitude of the negative number.

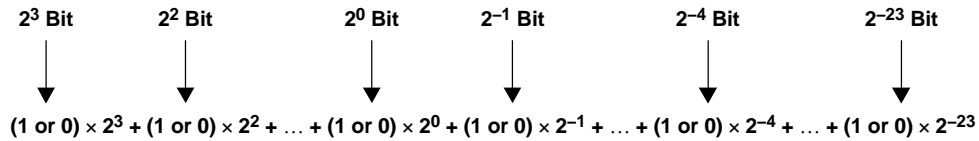

M0008-01

Figure 2-5. Conversion Weighting Factors—5.23 Format to Floating Point

Gain coefficients, entered via the I<sup>2</sup>C bus, must be entered as 32-bit binary numbers. The format of the 32-bit number (4-byte or 8-digit hexadecimal number) is shown in Figure 2-6.

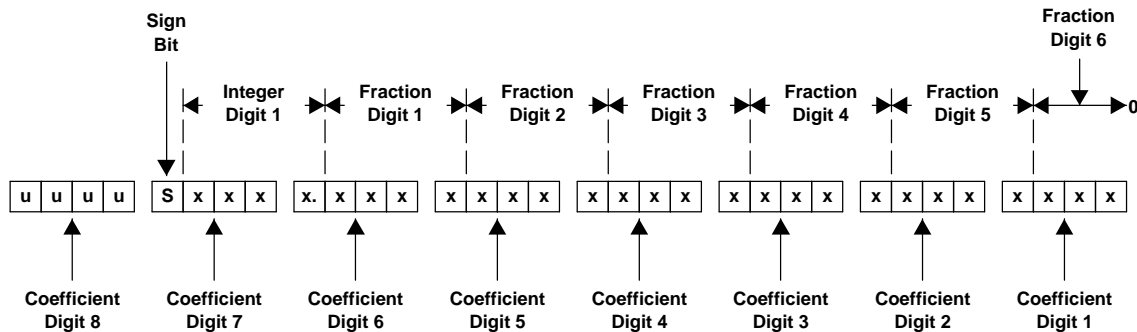

u = unused or don't care bits  
Digit = hexadecimal digit

M0009-01

Figure 2-6. Alignment of 5.23 Coefficient in 32-Bit I<sup>2</sup>C Word

As Figure 2-6 shows, the hexadecimal (hex) value of the integer part of the gain coefficient cannot be

concatenated with the hex value of the fractional part of the gain coefficient to form the 32-bit I<sup>2</sup>C coefficient. The reason is that the 28-bit coefficient contains 5 bits of integer, and thus the integer part of the coefficient occupies all of one hex digit and the most significant bit of the second hex digit. In the same way, the fractional part occupies the lower three bits of the second hex digit, and then occupies the other five hex digits (with the eighth digit being the zero-valued most significant hex digit).

### 2.3.2.2 48-Bit 25.23 Number Format

All level adjustment and threshold coefficients are 48-bit coefficients using a 25.23 number format. Numbers formatted as 25.23 numbers have 25 bits to the left of the decimal point and 23 bits to the right of the decimal point. This is shown in [Figure 2-7](#).

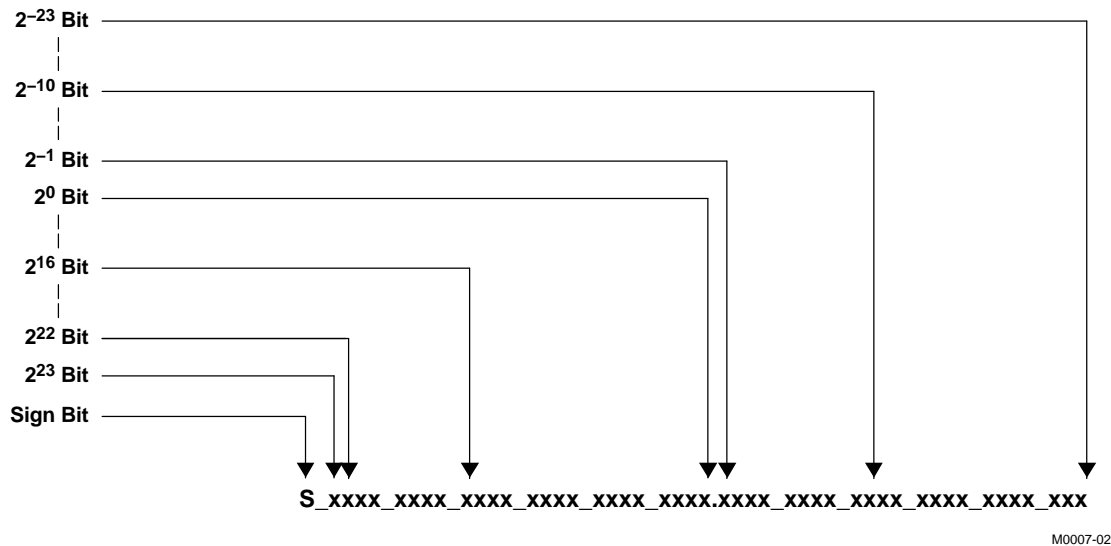

Figure 2-7. 25.23 Format

[Figure 2-8](#) shows the derivation of the decimal value of a 48-bit 25.23 format number.

$$\begin{array}{cccccc}
 2^{23} \text{ Bit} & 2^{22} \text{ Bit} & 2^0 \text{ Bit} & 2^{-1} \text{ Bit} & 2^{-23} \text{ Bit} & \\
 \downarrow & \downarrow & \downarrow & \downarrow & \downarrow & \\
 (1 \text{ or } 0) \times 2^{23} + (1 \text{ or } 0) \times 2^{22} + \dots + (1 \text{ or } 0) \times 2^0 + (1 \text{ or } 0) \times 2^{-1} + \dots + (1 \text{ or } 0) \times 2^{-23}
 \end{array}$$

Figure 2-8. Conversion Weighting Factors—25.23 Format to Floating Point

Two 32-bit words must be sent over the I<sup>2</sup>C bus to download a level or threshold coefficient into the TAS5508B. The alignment of the 48-bit, 25.23 formatted coefficient in the 8-byte (two 32-bit words) I<sup>2</sup>C word is shown in [Figure 2-9](#).

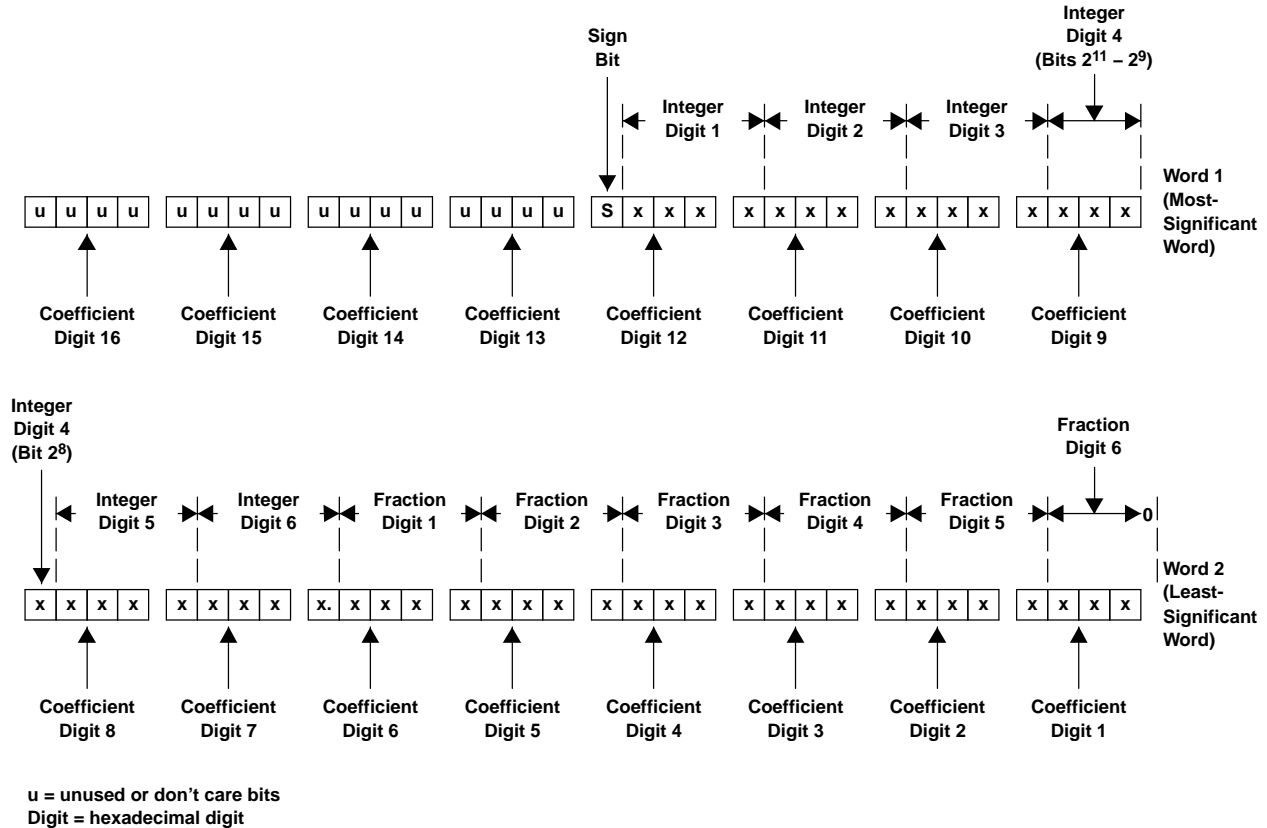
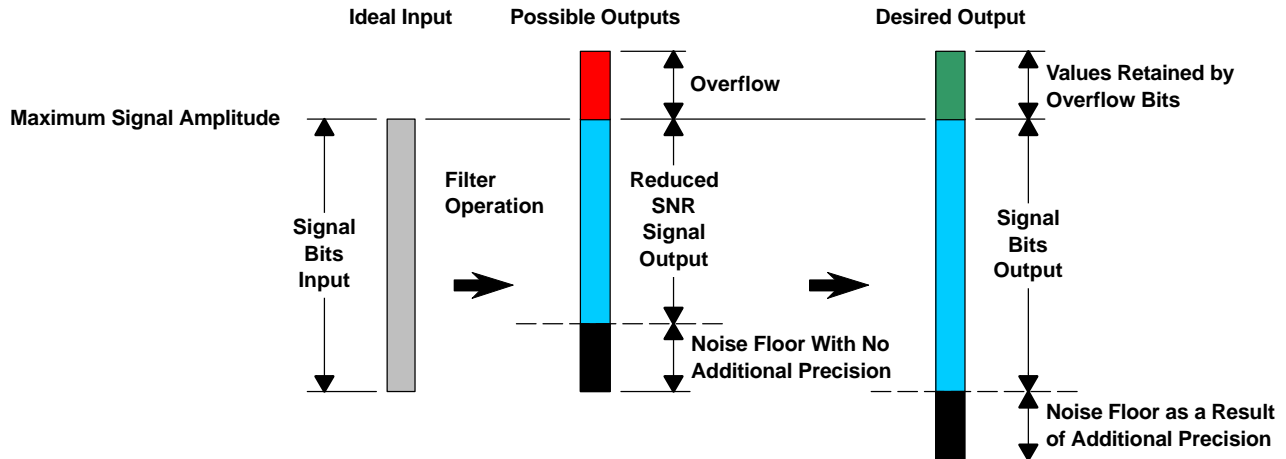

Figure 2-9. Alignment of 25.23 Coefficient in Two 32-Bit I<sup>2</sup>C Words

### 2.3.2.3 TAS5508B Audio Processing

The TAS5508B digital audio processing is designed so that noise produced by filter operations is maintained below the smallest signal amplitude of interest, as shown in Figure 2-10. The TAS5508B achieves this low noise level by increasing the precision of the signal representation substantially above the number of bits that are absolutely necessary to represent the input signal.

Similarly, the TAS5508B carries additional precision in the form of overflow bits to permit the value of intermediate calculations to exceed the input precision without clipping. The TAS5508B advanced digital audio processor achieves both of these important performance capabilities by using a high-performance digital audio-processing architecture with a 48-bit data path, 28-bit filter coefficients, and a 76-bit accumulator.



M0010-01

Figure 2-10. TAS5508B Digital Audio Processing

## 2.4 Input Crossbar Mixer

The TAS5508B has a full 8×8 input crossbar mixer. This mixer permits each signal-processing channel input to be any mix of any of the eight input channels, as shown in Figure 2-11. The control parameters for the input crossbar mixer are programmable via the I<sup>2</sup>C interface. See the *Input Mixer Registers, Channels 1–8 (0x41–0x48)*, Section 7.13, for more information.

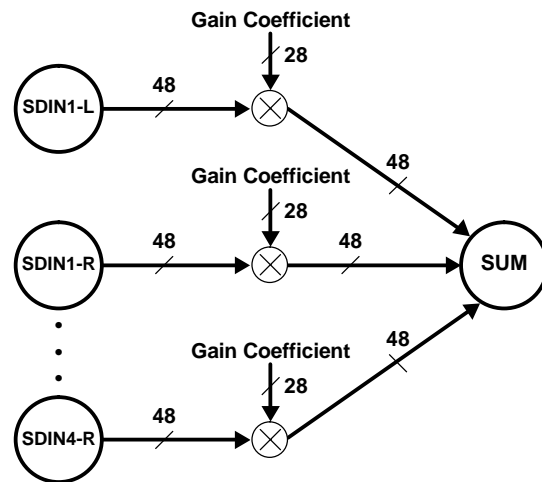

M0011-01

Figure 2-11. Input Crossbar Mixer

## 2.5 Biquad Filters

For 32-kHz to 96-kHz data, the TAS5508B provides 56 biquads across the eight channels (seven per channel).

For 176.4-kHz and 192-kHz data, the TAS5508B has 21 biquads across the three channels (seven per channel). All of the biquad filters are second-order direct form I structure.

The direct form I structure provides a separate delay element and mixer (gain coefficient) for each node in the biquad filter. Each mixer output is a signed 76-bit product of a signed 48-bit data sample (25.23 format number) and a signed 28-bit coefficient (5.23 format number), as shown in Figure 2-12. The 76-bit ALU in the TAS5508B allows the 76-bit resolution to be retained when summing the mixer outputs (filter products).

The five 28-bit coefficients for the each of the 56 biquads are programmable via the I<sup>2</sup>C interface. See Table 2-3.

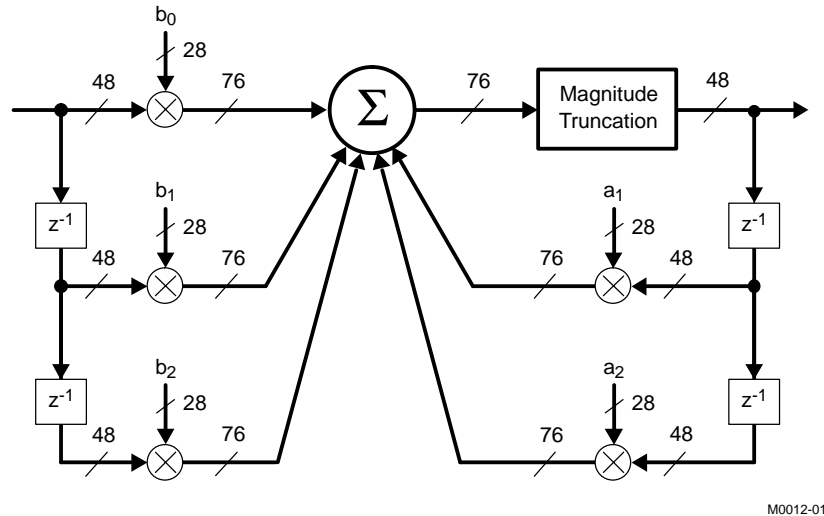

Figure 2-12. Biquad Filter Structure

All five coefficients for one biquad filter structure are written to one I<sup>2</sup>C register containing 20 bytes (or five 32-bit words). The structure is the same for all biquads in the TAS5508B. Registers 0x51–0x88 show all the biquads in the TAS5508B. Note that u[31:28] bits are unused and default to 0x0.

Table 2-3. Contents of One 20-Byte Biquad Filter Register (Default = All-Pass)

| DESCRIPTION                | REGISTER FIELD CONTENTS                           | INITIALIZATION GAIN COEFFICIENT VALUE |                        |
|----------------------------|---|---------------------------------------|------------------------|
|                            |   | DECIMAL                               | HEX                    |
| b <sub>0</sub> coefficient | u[31:28], b0[27:24], b0[23:16], b0[15:8], b0[7:0] | 1.0                                   | 0x00, 0x80, 0x00, 0x00 |
| b <sub>1</sub> coefficient | u[31:28], b1[27:24], b1[23:16], b1[15:8], b1[7:0] | 0.0                                   | 0x00, 0x00, 0x00, 0x00 |
| b <sub>2</sub> coefficient | u[31:28], b2[27:24], b2[23:16], b2[15:8], b2[7:0] | 0.0                                   | 0x00, 0x00, 0x00, 0x00 |
| a <sub>1</sub> coefficient | u[31:28], a1[27:24], a1[23:16], a1[15:8], a1[7:0] | 0.0                                   | 0x00, 0x00, 0x00, 0x00 |
| a <sub>2</sub> coefficient | u[31:28], a2[27:24], a2[23:16], a2[15:8], a2[7:0] | 0.0                                   | 0x00, 0x00, 0x00, 0x00 |

## 2.6 Bass and Treble Controls

From 32-kHz to 96-kHz data, the TAS5508B has four bass and treble tone controls. Each control has a ±18-dB control range with selectable corner frequencies and second-order slopes. These controls operate four channel groups:

- L, R, and C (channels 1, 2, and 7)
- LS, RS (channels 3 and 4)
- LBS, RBS (alternatively called L and R lineout) (channels 5 and 6)
- Sub (channel 8)

For 176.4-kHz and 192-kHz data, the TAS5508B has two bass and treble tone controls. Each control has a ±18-dB I<sup>2</sup>C control range with selectable corner frequencies and second-order slopes. These controls operate two channel groups:

- L and R
- Sub

The bass and treble filters use a soft update rate that does not produce artifacts during adjustment.

**Table 2-4. Bass and Treble Filter Selections**

| f <sub>s</sub><br>(kHz) | 3-dB CORNER FREQUENCIES, Hz |        |              |        |              |        |              |        |              |        |
|-------------------------|-----------------------------|--------|--------------|--------|--------------|--------|--------------|--------|--------------|--------|
|                         | FILTER SET 1                |        | FILTER SET 2 |        | FILTER SET 3 |        | FILTER SET 4 |        | FILTER SET 5 |        |
|                         | BASS                        | TREBLE | BASS         | TREBLE | BASS         | TREBLE | BASS         | TREBLE | BASS         | TREBLE |
| 32                      | 42                          | 917    | 83           | 1833   | 125          | 3000   | 146          | 3667   | 167          | 4333   |
| 38                      | 49                          | 1088   | 99           | 2177   | 148          | 3562   | 173          | 4354   | 198          | 5146   |
| 44.1                    | 57                          | 1263   | 115          | 2527   | 172          | 4134   | 201          | 5053   | 230          | 5972   |
| 48                      | 63                          | 1375   | 125          | 2750   | 188          | 4500   | 219          | 5500   | 250          | 6500   |
| 88.2                    | 115                         | 2527   | 230          | 5053   | 345          | 8269   | 402          | 10106  | 459          | 11944  |
| 96                      | 125                         | 2750   | 250          | 5500   | 375          | 9000   | 438          | 11000  | 500          | 13000  |
| 176.4                   | 230                         | 5053   | 459          | 10106  | 689          | 16538  | 804          | 20213  | 919          | 23888  |
| 192                     | 250                         | 5500   | 500          | 11000  | 750          | 18000  | 875          | 22000  | 1000         | 26000  |

The I<sup>2</sup>C registers that control bass and treble are:

- Bass and treble bypass register (0x89–0x90, channels 1–8)
- Bass and treble slew rates (0xD0)
- Bass filter sets 1–5 (0xDA)
- Bass filter index (0xDB)
- Treble filter sets 1–5 (0xDC)
- Treble filter index (0xDD)

**Note that the bass and treble bypass registers (0x89–0x90) are defaulted to the bypass mode. In order to use the bass and treble, these registers must be in the inline (or enabled) mode for each channel using bass and treble.**

## 2.7 Volume, Automute, and Mute

The TAS5508B provides individual channel and master volume controls. Each control provides an adjustment range of 18 dB to –109 dB in 0.25-dB increments. This permits a total volume device control range of 36 dB to –109 dB plus mute. The master volume control can be configured to control six or eight channels.

The TAS5508B has a master soft mute control that can be enabled by a terminal or I<sup>2</sup>C command. The device also has individual channel soft mute controls that are enabled via I<sup>2</sup>C.

The soft volume and mute update rates are programmable. The soft adjustments are performed using a soft-gain linear update with an I<sup>2</sup>C-programmable linear step size at a fixed temporal rate. The linear soft-gain step size can be varied from 0.5 to 0.003906. [Table 2-5](#) lists the linear gain step sizes.

**Table 2-5. Linear Gain Step Size**

| STEP SIZE (GAIN)                       | 0.5   | 0.25  | 0.125 | 0.0625 | 0.03125 | 0.015625 | 0.007813 | 0.003906 |
|--|-------|-------|-------|--------|---------|----------|----------|----------|
| Time to go from 36 db to –109 dB in ms | 10.67 | 21.33 | 42.67 | 85.34  | 170.67  | 340.35   | 682.70   | 1365.4   |
| Time to go from 18 db to –109 dB in ms | 1.33  | 2.67  | 5.33  | 10.67  | 21.33   | 42.67    | 85.33    | 170.67   |
| Time to go from 0 db to –109 dB in ms  | 0.17  | 0.33  | 0.67  | 1.33   | 2.67    | 5.33     | 10.67    | 21.33    |



## 2.8 Automute and Mute Channel Controls

The TAS5508B has individual channel automute controls that are enabled via I<sup>2</sup>C register 0x04 bits D5 and D6 (the default setting is **enabled**). Two separate detectors can trigger the automute:

- Input automute (I<sup>2</sup>C register 0x14): All channels are muted when all 8 inputs to the TAS5508B are less in magnitude than the input threshold value for a programmable amount of time.
- Output automute (I<sup>2</sup>C register 0x15): A single channel is muted when the output of the DAP section is less in magnitude than the input threshold value for a programmable amount of time.

The detection period and thresholds for these two detectors are the same.

This time interval is selectable via I<sup>2</sup>C to be from 1 ms to 110 ms. The increments of time are 1, 2, 3, 4, 5, 10, 20, 30, 40, 50, 60, 70, 80, 90, 100, and 110 ms. This interval is independent of the sample rate. The default value is mask programmable.

The input threshold value is an unsigned magnitude that is expressed as a bit position. This value is adjustable via I<sup>2</sup>C. The range of the input threshold adjustment is from below the LSB (bit position 0) to below bit position 12 in a 24-bit input-data word. This range provides an input threshold that can be adjusted for 12 to 24 bits of data. The default value is mask programmable.

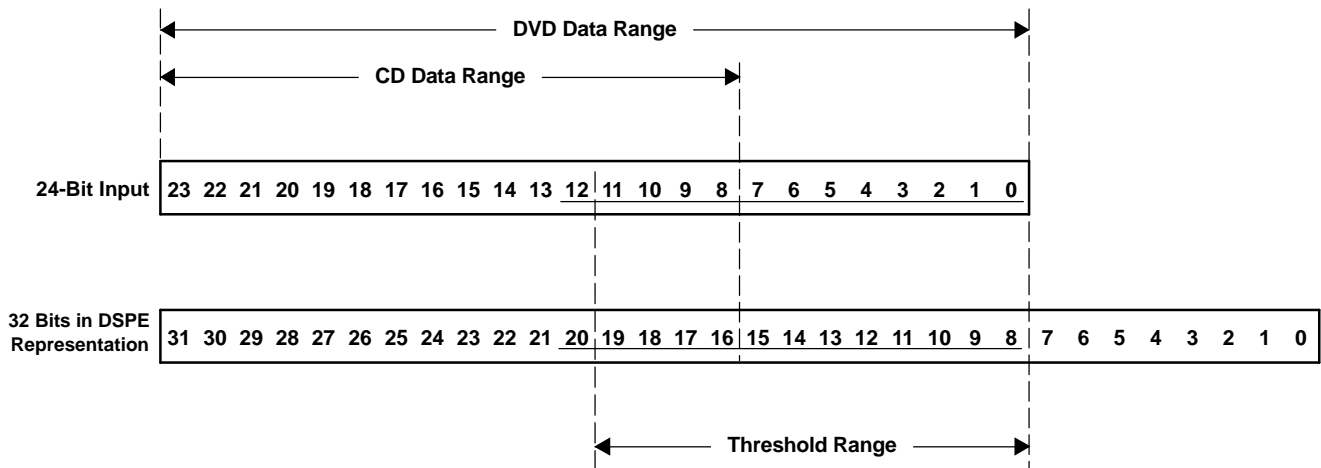

**Figure 2-13. Automute Threshold**

The automute state is exited when the TAS5508B receives one sample that is greater than the output threshold.

The output threshold can be one of two values:

- Equal to the input threshold
- 6 dB (one bit position) greater than the input threshold

The value for the output threshold is selectable via I<sup>2</sup>C. The default value is mask programmable.

The system latency enables the data value that is above the threshold to be preserved and output.

A mute command initiated by automute, master mute, individual I<sup>2</sup>C mute, the AM interference mute sequence, or the bank-switch mute sequence overrides an unmute command or a volume command. While a mute command is activated, the commanded channels transition to the mute state. When a channel is unmuted, it goes to the last commanded volume setting that has been received for that channel.

## 2.9 Loudness Compensation

The loudness compensation function compensates for the Fletcher-Munson loudness curves. The TAS5508B loudness implementation tracks the volume control setting to provide spectral compensation for weak low- or high-frequency response at low volume levels. For the volume tracking function, both linear and logarithmic control laws can be implemented. Any biquad filter response can be used to provide the desired loudness curve. The control parameters for the loudness control are programmable via the I<sup>2</sup>C interface.

The TAS5508B has a single set of loudness controls for the eight channels. In 6-channel mode, loudness is available to the six speaker outputs and also to the line outputs. The loudness control input uses the maximum individual master volume (V) to control the loudness that is applied to all channels. In the 192-kHz and 176.4-kHz modes, the loudness function is active only for channels 1, 2, and 8.

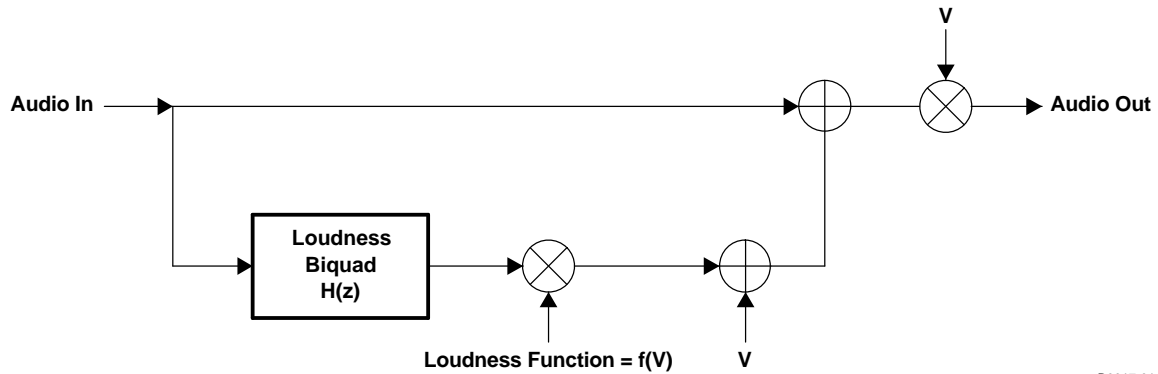

B0017-01

Figure 2-14. Loudness Compensation Functional Block Diagram

Loudness function =  $f(V) = G \times [2^{(\text{Log } V) \times \text{LG} + \text{LO}}] + O$  or alternatively,

Loudness function =  $f(V) = G \times [V^{\text{LG}} \times 2^{\text{LO}}] + O$

For example, for the default values  $\text{LG} = -0.5$ ,  $\text{LO} = 0$ ,  $G = 1$ , and  $O = 0$ , then:

Loudness function =  $1/\text{SQRT}(V)$ , which is the recommended transfer function for loudness. So,

Audio out = (audio in)  $\times V + H(Z) \times \text{SQRT}(V)$ . Other transfer functions are possible.

Table 2-6. Default Loudness Compensation Parameters

| LOUDNESS TERM | DESCRIPTION                   | USAGE                                       | DATA FORMAT | I <sup>2</sup> C SUB-ADDRESS | DEFAULT  |  |
|---------------|-------------------------------|---|-------------|------------------------------|--|--|
|               |                               |   |             |                              | HEX  | FLOAT  |
| V             | Max volume                    | Gains audio                                 | 5.23        | NA                           | NA   | NA   |
| Log V         | Log <sub>2</sub> (max volume) | Loudness function                           | 5.23        | NA                           | 0000 0000  | 0.0  |
| H(Z)          | Loudness biquad               | Controls shape of loudness curves           | 5.23        | 0x95                         | b <sub>0</sub> = 0000 D513<br>b <sub>1</sub> = 0000 0000<br>b <sub>2</sub> = 0FFF 2AED<br>a <sub>1</sub> = 00FE 5045<br>a <sub>2</sub> = 0F81 AA27 | b <sub>0</sub> = 0.006503<br>b <sub>1</sub> = 0<br>b <sub>2</sub> = -0.006503<br>a <sub>1</sub> = 1.986825<br>a <sub>2</sub> = -0.986995 |
| LG            | Gain (log space)              | Loudness function                           | 5.23        | 0x91                         | FFC0 0000  | -0.5   |
| LO            | Offset (log space)            | Loudness function                           | 25.23       | 0x92                         | 0000 0000  | 0  |
| G             | Gain                          | Switch to enable loudness (ON = 1, OFF = 0) | 5.23        | 0x93                         | 0000 0000  | 0  |
| O             | Offset                        | Provides offset                             | 25.23       | 0x94                         | 0000 0000  | 0  |

### 2.9.1 Loudness Example

Problem: Due to the Fletcher-Munson phenomena, compensation for low-frequency attenuation near 60 Hz is desirable. The TAS5508B provides a loudness transfer function with EQ gain = 6, EQ center frequency = 60 Hz, and EQ bandwidth = 60 Hz.

Solution: Using Texas Instruments ALE TAS5508B DSP tool, Matlab™, or other signal-processing tool, develop a loudness function with the parameters listed in Table 2-7.

Table 2-7. Example Loudness Function Parameters

| LOUDNESS TERM | DESCRIPTION     | USAGE                                       | DATA FORMAT | I <sup>2</sup> C SUB-ADDRESS | EXAMPLE  |  |
|---------------|-----------------|---|-------------|------------------------------|--|--|
|               |                 |   |             |                              | HEX  | FLOAT  |
| H(Z)          | Loudness biquad | Controls shape of loudness curves           | 5.23        | 0x95                         | b <sub>0</sub> = 0000 8ACE<br>b <sub>1</sub> = 0000 0000<br>b <sub>2</sub> = FFFF 7532<br>a <sub>1</sub> = FF01 1951<br>a <sub>2</sub> = 007E E914 | b <sub>0</sub> = 0.004236<br>b <sub>1</sub> = 0<br>b <sub>2</sub> = -0.004236<br>a <sub>1</sub> = -1.991415<br>a <sub>2</sub> = 0.991488 |
| LG            | Loudness gain   | Loudness function                           | 5.23        | 0x91                         | FFC0 0000  | -0.5   |
| LO            | Loudness offset | Loudness function                           | 25.23       | 0x92                         | 0000 0000  | 0  |
| G             | Gain            | Switch to enable loudness (ON = 1, OFF = 0) | 5.23        | 0x93                         | 0080 0000  | 1  |
| O             | Offset          | Offset                                      | 25.23       | 0x94                         | 0000 0000  | 0  |

See Figure 2-15 for the resulting loudness function at different gains.

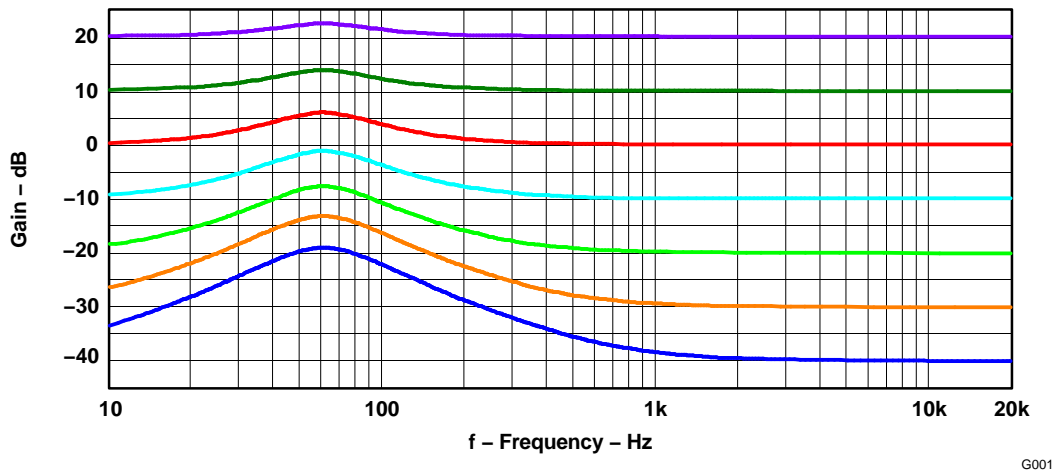

Figure 2-15. Loudness Example Plots

### 2.10 Dynamic Range Control (DRC)

DRC provides both compression and expansion capabilities over three separate and definable regions of audio signal levels. Programmable threshold levels set the boundaries of the three regions. Within each of the three regions, a distinct compression or expansion transfer function can be established and the slope of each transfer function is determined by programmable parameters. The offset (boost or cut) at the two boundaries defining the three regions can also be set by programmable offset coefficients. The DRC implements the composite transfer function by computing a 5.23-format gain coefficient from each sample output from the rms estimator. This gain coefficient is then applied to a mixer element, whose other input is the audio data stream. The mixer output is the DRC-adjusted audio data.

The TAS5508B has two distinct DRC blocks. DRC1 services channels 1–7 in the 8-channel mode and channels 1–4 and 7 in the 6-channel mode. This DRC computes rms estimates of the audio data streams

on all channels that it controls. The estimates are then compared on a sample-by-sample basis and the larger of the estimates is used to compute the compression/expansion gain coefficient. The gain coefficient is then applied to the appropriate channel audio streams. DRC2 services only channel 8. This DRC also computes an rms estimate of the signal level on channel 8 and this estimate is used to compute the compression/expansion gain coefficient applied to the channel-8 audio stream.

All of the TAS5508B default values for DRC can be used except for the DRC1 decay and DRC2 decay. [Table 2-8](#) shows the recommended time constants and their hex values. If the user wants to implement other DRC functions, Texas Instruments recommends using the automatic loudspeaker equalization (ALE) tool available from Texas Instruments. The ALE tool allows the user to select the DRC transfer function graphically. It then outputs the TAS5508B hex coefficients for download to the TAS5508B.

**Table 2-8. DRC Recommended Changes From TAS5508B Defaults**

| I <sup>2</sup> C SUBADDRESS | REGISTER FIELDS   | RECOMMENDED TIME CONSTANT (ms) | RECOMMENDED HEX VALUE | DEFAULT HEX |
|-----------------------------|-------------------|--------------------------------|-----------------------|-------------|
| 0x98                        | DRC1 energy       | 5                              | 0000 883F             | 0000 883F   |
|                             | DRC1 (1 – energy) |                                | 007F 77C0             | 007F 77C0   |
| 0x9C                        | DRC1 attack       | 5                              | 0000 883F             | 0000 883F   |
|                             | DRC1 (1 – attack) |                                | 007F 77C0             | 007F 77C0   |
|                             | DRC1 decay        | 2                              | 0001 538F             | 0000 00AE   |
|                             | DRC1 (1 – decay)  |                                | 007E AC70             | 007F FF51   |
| 0x9D                        | DRC2 energy       | 5                              | 0000 883F             | 0000 883F   |
|                             | DRC2 (1 – energy) |                                | 007F 77C0             | 007F 77C0   |
| 0xA1                        | DRC2 attack       | 5                              | 0000 883F             | 0000 883F   |
|                             | DRC2 (1 – attack) |                                | 007F 77C0             | 007F 77C0   |
|                             | DRC2 decay        | 2                              | 0001 538F             | 0000 0056   |
|                             | DRC2 (1 – decay)  |                                | 007E AC70             | 003F FFA8   |

Recommended DRC setup flow if the defaults are used:

- After power up, load the recommended hex value for DRC1 and DRC2 decay and (1 – decay). See [Table 2-8](#).
- Enable either the pre-volume or post-volume DRC using I<sup>2</sup>C registers 0x96 and 0x97. Note that to avoid a potential timing problem, there should be a 10-ms delay between a write to 0x96 and a write to 0x97.

Recommended DRC setup flow if the DRC design uses values different from the defaults:

- After power up, load all DRC coefficients per the DRC design.
- Enable either the pre-volume or post-volume DRC. Note that to avoid a potential timing problem, there should be a 10-ms delay between a write to 0x96 and a write to 0x97.

[Figure 2-16](#) shows the positioning of the DRC block in the TAS5508B processing flow. As seen, the DRC input can come either before or after soft volume control and loudness processing.

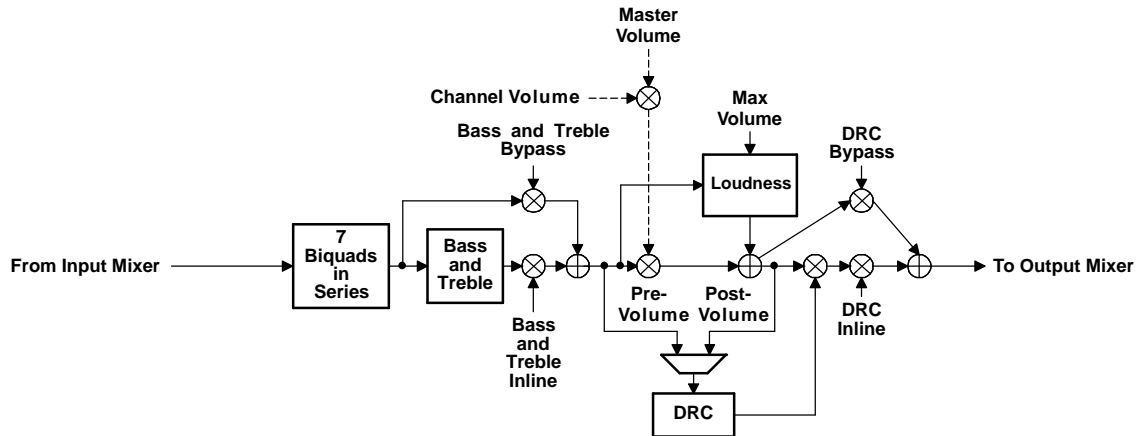

B0016-02

Figure 2-16. DRC Positioning in TAS5508B Processing Flow

Figure 2-17 illustrates a typical DRC transfer function.

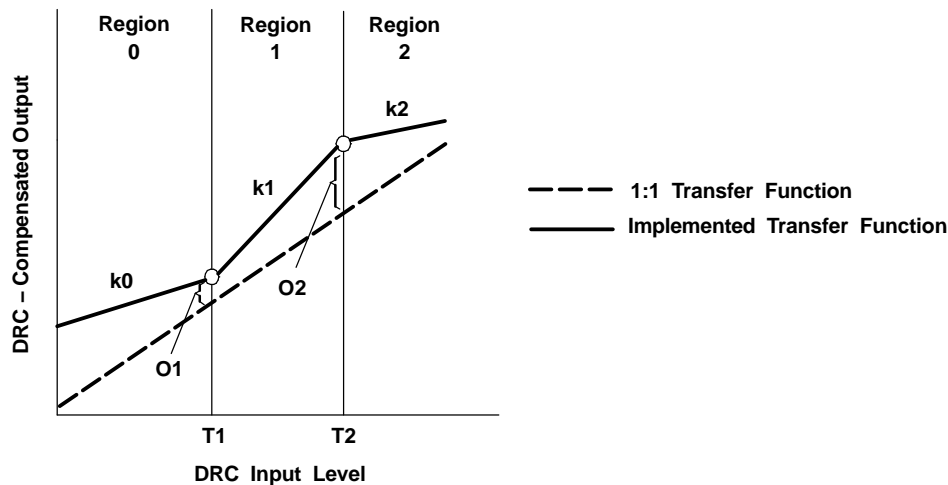

M0014-01

Figure 2-17. Dynamic Range Compression (DRC) Transfer Function Structure

The three regions shown in Figure 2-17 are defined by three sets of programmable coefficients:

- Thresholds T1 and T2 define region boundaries.
- Offsets O1 and O2 define the DRC gain coefficient settings at thresholds T1 and T2, respectively.
- Slopes k0, k1, and k2 define whether compression or expansion is to be performed within a given region. The magnitudes of the slopes define the degree of compression or expansion to be performed.

The three sets of parameters are all defined in logarithmic space and adhere to the following rules:

- The maximum input sample into the DRC is referenced at 0 dB. All values below this maximum value then have negative values in logarithmic (dB) space.
- The samples input into the DRC are 32-bit words and consist of the upper 32 bits of the 48-bit word format used by the digital audio processor (DAP). The 48-bit DAP word is derived from the 32-bit serial data received at the serial-audio receive port by adding 8 bits of headroom above the 32-bit word and 8 bits of computational precision below the 32-bit word. If the audio-processing steps between the SAP input and the DRC input result in no accumulative boost or cut, the DRC operates on the 8 bits of headroom and the 24 MSBs of the audio sample. Under these conditions, a 0-dB (maximum value) audio sample (0x7FFF FFFF) is seen at the DRC input as a -48-dB sample (8 bits  $\times$  -6 dB/bit = -48 dB).

- Thresholds T1 and T2 define, in dB, the boundaries of the three regions of the DRC, as referenced to the rms value of the data into the DRC. Zero-valued threshold settings reference the maximum-valued rms input into the DRC and negative-valued thresholds reference all other rms input levels. Positive-valued thresholds have no physical meaning and are not allowed. In addition, zero-valued threshold settings are not allowed.

Although the DRC input is limited to 32-bit words, the DRC itself operates using the 48-bit word format of the DAP. The 32-bit samples input into the DRC are placed in the upper 32 bits of this 48-bit word space. This means that the threshold settings must be programmed as 48-bit (25.23 format) numbers.

**CAUTION**

**Zero-valued and positive-valued threshold settings are not allowed and cause unpredictable behavior if used.**

- Offsets O1 and O2 define, in dB, the attenuation (cut) or gain (boost) applied by the DRC-derived gain coefficient at the threshold points T1 and T2, respectively. Positive offsets are defined as cuts, and thus boost or gain selections are negative numbers. Offsets must be programmed as 48-bit (25.23 format) numbers.
- Slopes k0, k1, and k2 define whether compression or expansion is to be performed within a given region, and the degree of compression or expansion to be applied. Slopes are programmed as 28-bit (5.23 format) numbers.

**2.10.1 DRC Implementation**

The three elements comprising the DRC include: (1) an rms estimator, (2) a compression/expansion coefficient computation engine, and (3) an attack/decay controller.

- RMS estimator—This DRC element derives an estimate of the rms value of the audio data stream into the DRC. For the DRC block shared by Ch1 and Ch2, two estimates are computed—an estimate of the Ch1 audio data stream into the DRC, and an estimate of the Ch2 audio data stream into the DRC. The outputs of the two estimators are then compared, sample-by-sample, and the larger-valued sample is forwarded to the compression/expansion coefficient computation engine.

Two programmable parameters, *ae* and  $(1 - ae)$ , set the effective time window over which the rms estimate is made. For the DRC block shared by Ch1 and Ch2, the programmable parameters apply to both rms estimators. The time window over which the rms estimation is computed can be determined by:

$$t_{\text{window}} = \frac{-1}{f_S \ln(1 - ae)}$$

- Compression/expansion coefficient computation—This DRC element converts the output of the rms estimator to a logarithmic number, determines the region where the input resides, and then computes and outputs the appropriate coefficient to the attack/decay element. Seven programmable parameters, T1, T2, O1, O2, k0, k1, and k2, define the three compression/expansion regions implemented by this element.
- Attack/decay control—This DRC element controls the transition time of changes in the coefficient computed in the compression/expansion coefficient computation element. Four programmable parameters define the operation of this element. Parameters *ad* and  $(1 - ad)$  set the decay or release time constant to be used for volume boost (expansion). Parameters *aa* and  $(1 - aa)$  set the attack time constant to be used for volume cuts. The transition time constants can be determined by:

$$t_a = \frac{-1}{f_S \ln(1 - aa)} \qquad t_d = \frac{-1}{f_S \ln(1 - ad)}$$

## 2.10.2 Compression/Expansion Coefficient Computation Engine Parameters

Seven programmable parameters are assigned to each DRC block: two threshold parameters—T1 and T2, two offset parameters—O1 and O2, and three slope parameters—k0, k1, and k2. The threshold parameters establish the three regions of the DRC transfer curve, the offsets anchor the transfer curve by establishing known gain settings at the threshold levels, and the slope parameters define whether a given region is a compression or an expansion region.

The audio input stream into the DRC must pass through DRC-dedicated programmable input mixers. These mixers are provided to scale the 32-bit input into the DRC to account for the positioning of the audio data in the 48-bit DAP word and the net gain or attenuation in signal level between the SAP input and the DRC. The selection of threshold values must take the gain (attenuation) of these mixers into account. The DRC implementation examples that follow illustrate the effect these mixers have on establishing the threshold settings.

T2 establishes the boundary between the high-volume region and the mid-volume region. T1 establishes the boundary between the mid-volume region and the low-volume region. Both thresholds are set in logarithmic space, and which region is active for any given rms estimator output sample is determined by the logarithmic value of the sample.

Threshold T2 serves as the fulcrum or pivot point in the DRC transfer function. O2 defines the boost (> 0 dB) or cut (< 0 dB) implemented by the DRC-derived gain coefficient for an rms input level of T2. If O2 = 0 dB, the value of the derived gain coefficient is 1 (0x0080 0000 in 5.23 format). k2 is the slope of the DRC transfer function for rms input levels above T2, and k1 is the slope of the DRC transfer function for rms input levels below T2 (and above T1). The labeling of T2 as the fulcrum stems from the fact that there cannot be a discontinuity in the transfer function at T2. The user can, however, set the DRC parameters to realize a discontinuity in the transfer function at the boundary defined by T1. If no discontinuity is desired at T1, the value for the offset term O1 must obey the following equation.

$$O1_{\text{No Discontinuity}} = |T1 - T2| \times k1 + O2 \quad \text{For } (|T1| \geq |T2|)$$

T1 and T2 are the threshold settings in dB, k1 is the slope for region 1, and O2 is the offset in dB at T2. If the user chooses to select a value of O1 that does not obey the above equation, a discontinuity at T1 is realized.

Decreasing in volume from T2, the slope k1 remains in effect until the input level T1 is reached. If, at this input level, the offset of the transfer function curve from the 1 : 1 transfer curve does not equal O1, there is a discontinuity at this input level as the transfer function is snapped to the offset called for by O1. If no discontinuity is wanted, O1 and/or k1 must be adjusted so that the value of the transfer curve at input level T1 is offset from the 1 : 1 transfer curve by the value O1. The examples that follow illustrate both continuous and discontinuous transfer curves at T1.

Decreasing in volume from T1, starting at offset level O1, slope k0 defines the compression/expansion activity in the lower region of the DRC transfer curve.

### 2.10.2.1 Threshold Parameter Computation

For thresholds,

$$T_{\text{dB}} = -6.0206T_{\text{INPUT}} = -6.0206T_{\text{SUB\_ADDRESS\_ENTRY}}$$

If, for example, it is desired to set T1 = -64 dB, then the subaddress entry required to set T1 to -64 dB is:

$$T1_{\text{SUB\_ADDRESS\_ENTRY}} = \frac{-64}{-6.0206} = 10.63$$

T1 is entered as a 48-bit number in 25.23 format. Therefore:

$$\begin{aligned}
 T1 = 10.63 &= 0\ 1010.1010\ 0001\ 0100\ 0111\ 1010\ 111 \\
 &= 0x0000\ 0550\ A3D7 \text{ in 25.23 format}
 \end{aligned}$$

### 2.10.2.2 Offset Parameter Computation

The offsets set the boost or cut applied by the DRC-derived gain coefficient at the threshold point. An equivalent statement is that offsets represent the departure of the actual transfer function from a 1 : 1 transfer at the threshold point. Offsets are 25.23-formatted, 48-bit logarithmic numbers. They are computed by the following equation.

$$O_{\text{INPUT}} = \frac{O_{\text{DESIRED}} + 24.0824 \text{ dB}}{6.0206}$$

Gains or boosts are represented as negative numbers; cuts or attenuations are represented as positive numbers. For example, to achieve a boost of 21 dB at threshold T1, the I<sup>2</sup>C coefficient value entered for O1 must be:

$$\begin{aligned} O1_{\text{INPUT}} &= \frac{-21 \text{ dB} + 24.0824 \text{ dB}}{6.0206} = 0.51197555 \\ &= 0.1000\_0011\_0001\_1101\_0100 \\ &= 0x00000041886A \text{ in 25.23 format} \end{aligned}$$

### 2.10.2.3 Slope Parameter Computation

In developing the equations used to determine the subaddress of the input value required to realize a given compression or expansion within a given region of the DRC, the following convention is adopted.

$$\text{DRC transfer} = \text{Input increase} : \text{Output increase}$$

If the DRC realizes an output increase of n dB for every dB increase in the rms value of the audio into the DRC, a 1 : n expansion is being performed. If the DRC realizes a 1-dB increase in output level for every n-dB increase in the rms value of the audio into the DRC, an n : 1 compression is being performed.

$$k = n - 1$$

For n : 1 compression, the slope k can be found by:  $k = \frac{1}{n} - 1$

In both expansion (1 : n) and compression (n : 1), n is implied to be greater than 1. Thus, for expansion:

$k = n - 1$  means  $k > 0$  for  $n > 1$ . Likewise, for compression,  $k = \frac{1}{n} - 1$  means  $-1 < k < 0$  for  $n > 1$ . Thus, it appears that k must always lie in the range  $k > -1$ .

The DRC imposes no such restriction and k can be programmed to values as negative as -15.999. To determine what results when such values of k are entered, it is first helpful to note that the compression and expansion equations for k are actually the same equation. For example, a 1 : 2 expansion is also a 0.5 : 1 compression.

$$0.5 : 1 \text{ compression} \Rightarrow k = \frac{1}{0.5} - 1 = 1$$

$$1 : 2 \text{ expansion} \Rightarrow k = 2 - 1 = 1$$

As can be seen, the same value for k is obtained either way. The ability to choose values of k less than -1 allows the DRC to implement negative-slope transfer curves within a given region. Negative-slope transfer curves are usually not associated with compression and expansion operations, but the definition of these operations can be expanded to include negative-slope transfer functions. For example, if  $k = -4$

$$\text{Compression equation: } k = -4 = \frac{1}{n} - 1 \Rightarrow n = -\frac{1}{3} \Rightarrow -0.3333 : 1 \text{ compression}$$

$$\text{Expansion equation: } k = -4 = n - 1 \Rightarrow n = -3 \Rightarrow 1 : -3 \text{ expansion}$$

With  $k = -4$ , the output decreases 3 dB for every 1 dB increase in the rms value of the audio into the DRC. As the input increases in volume, the output decreases in volume.



## 2.11 Output Mixer

The TAS5508B provides an 8×2 output mixer for channels 1, 2, 3, 4, 5, and 6. For channels 7 and 8, the TAS5508B provides an 8×3 output mixer. These mixers allow each output to be any mix of any two (or three) signal-processed channels. The control parameters for the output crossbar mixer are programmable via the I<sup>2</sup>C interface. All of the TAS5508B features are available when the 8×2 and 8×3 output mixers are configured in the pass-through output mixer configuration, where the audio data from each DAP channel maps directly to the corresponding PWM channel (i.e., DAP channel 1 to PWM channel 1, etc).

When mixing or remapping DAP channels to different PWM output channels there are limitations to consider:

- Individual channel mute should not be used.
- The sum of the minimum channel volume and master volume should not be below –109 dB.

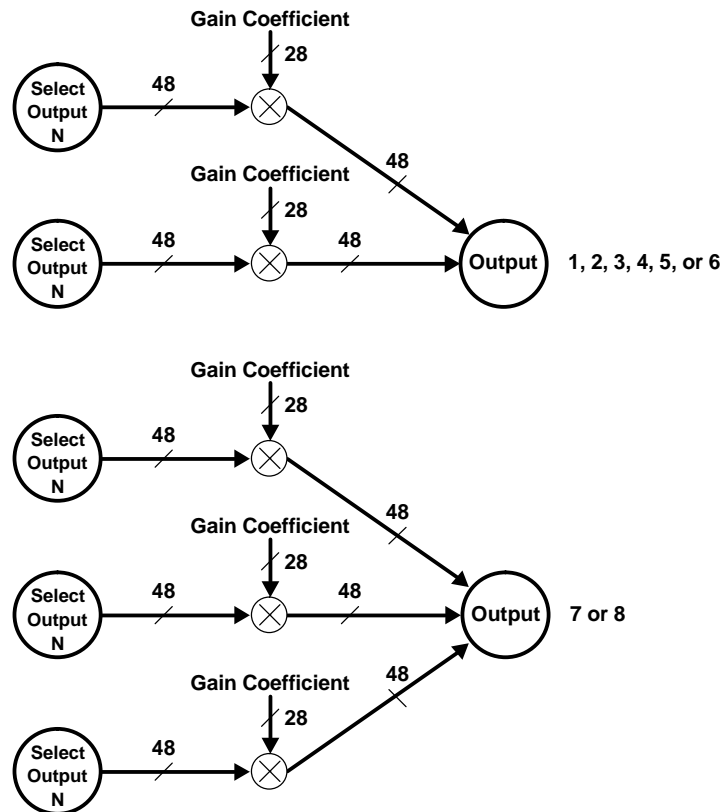

M0011-02

Figure 2-18. Output Mixers

## 2.12 PWM

The TAS5508B has eight channels of high-performance digital PWM modulators that are designed to drive switching output stages (back ends) in both single-ended (SE) and H-bridge (bridge-tied-load) configurations. The TAS5508B device uses noise-shaping and sophisticated, error-correction algorithms to achieve high power efficiency and high-performance digital audio reproduction. The TAS5508B uses an AD1 PWM modulation scheme combined with a fifth-order noise shaper to provide a 102-dB SNR from 20 Hz to 20 kHz.

The PWM section accepts 32-bit PCM data from the DAP and outputs eight PWM audio output channels configurable as either:

- Six channels to drive power stages and two channels to drive a differential-input active filter to provide a separately controllable stereo lineout
- Eight channels to drive power stages

The TAS5508B PWM section output supports both single-ended and bridge-tied loads.

The PWM section provides a headphone PWM output to drive an external differential amplifier like the TPA112. The headphone circuit uses the PWM modulator for channels 1 and 2. The headphone does not operate while the six or eight back-end drive channels are operating. The headphone is enabled via a headphone-select terminal.

The PWM section has individual-channel dc-blocking filters that can be enabled and disabled. The filter cutoff frequency is less than 1 Hz.

The PWM section has individual-channel de-emphasis filters for 32, 44.1, and 48 kHz that can be enabled and disabled.

The PWM section also contains the power-supply volume control (PSVC) PWM.

The interpolator, noise shaper, and PWM sections provide a PWM output with the following features:

- Up to 8× oversampling
  - 8× at  $f_s = 44.1$  kHz, 48 kHz, 32 kHz, 38 kHz
  - 4× at  $f_s = 88.2$  kHz, 96 kHz
  - 2× at  $f_s = 176.4$  kHz, 192 kHz
- Fifth-order noise shaping
- 100-dB dynamic range 0–20 kHz (TAS5508B + TAS5111 system measured at speaker terminals)
- THD < 0.01%
- Adjustable maximum modulation limit of 93.8% to 99.2%
- 3.3-V digital signal

### 2.12.1 DC Blocking (High-Pass Filter Enable/Disable)

Each input channel incorporates a first-order, digital, high-pass filter to block potential dc components. The filter –3-dB point is approximately 0.89-Hz at the 44.1-kHz sampling rate. The high-pass filter can be enabled and disabled via the I<sup>2</sup>C system control register 1 (0x03 bit D7). The default setting is 1 (high-pass filter enabled).

### 2.12.2 De-Emphasis Filter

For audio sources that have been pre-emphasized, a precision 50- $\mu$ s/15- $\mu$ s de-emphasis filter is provided to support the sampling rates of 32 kHz, 44.1 kHz, and 48 kHz. Figure 2-19 shows a graph of the de-emphasis filtering characteristics. De-emphasis is set using two bits in the system control register.

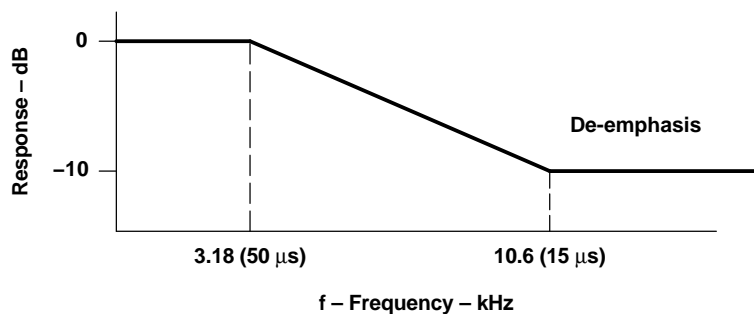

M0015-01

**Figure 2-19. De-Emphasis Filter Characteristics**

### 2.12.3 Power-Supply Volume Control (PSVC)

The TAS5508B supports volume control both by conventional digital gain/attenuation and by a combination of digital and analog gain/attenuation. Varying the H-bridge power-supply voltage performs the analog volume control function. The benefits of using power-supply volume control (PSVC) are reduced idle channel noise, improved signal resolution at low volumes, increased dynamic range, and reduced radio frequency emissions at reduced power levels. The PSVC is enabled via I<sup>2</sup>C. When enabled, the PSVC provides a PWM output that is filtered to provide a reference voltage for the power supply. The power-supply adjustment range can be set for -12, -18, or -24 dB, to accommodate a range of variable power-supply designs.

Figure 2-20 and Figure 2-21 show how power-supply and digital gains can be used together.

The volume biquad (0xCF) can be used to implement a low-pass filter in the digital volume control to match the PSVC volume transfer function. Note that if the PVSC function is not used, the volume biquad should be all-pass (default).

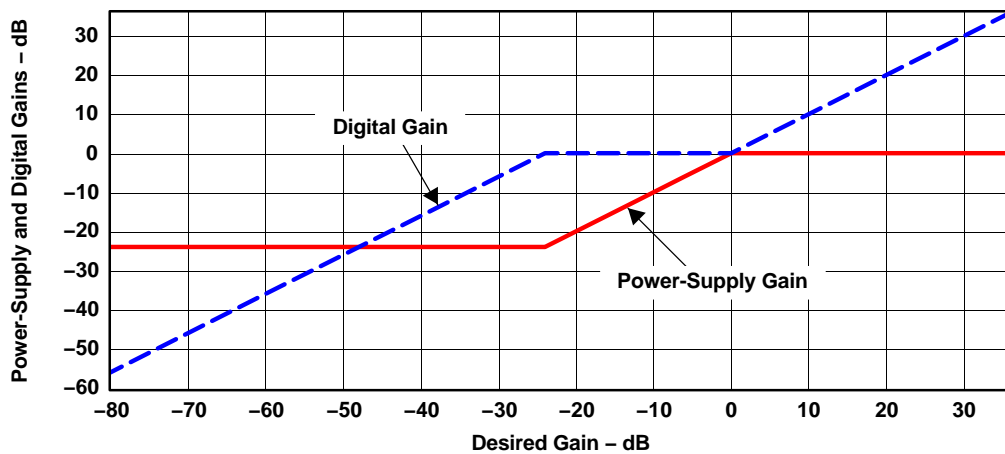

G002

Figure 2-20. Power-Supply and Digital Gains (Linear Space)

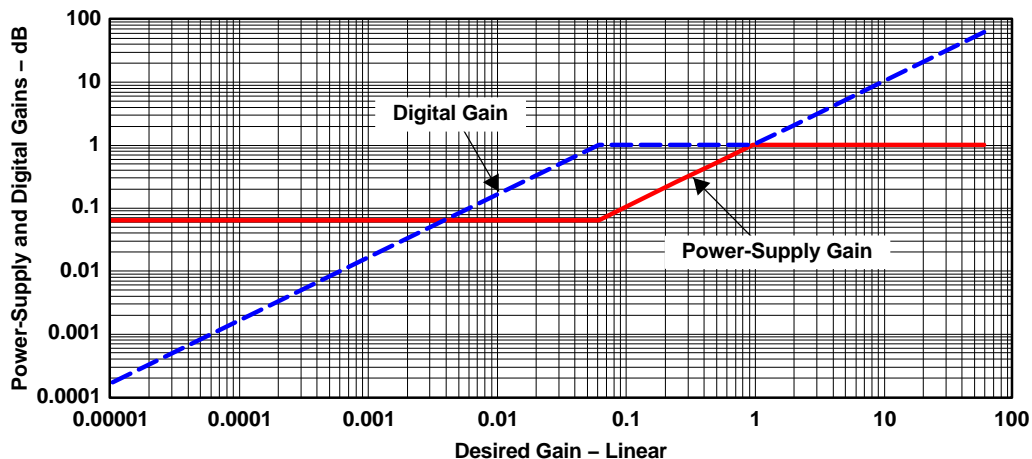

G003

Figure 2-21. Power-Supply and Digital Gains (Log Space)

### 2.12.4 AM Interference Avoidance

Digital amplifiers can degrade AM reception as a result of their RF emissions. Texas Instruments' patented AM interference-avoidance circuit provides a flexible system solution for a wide variety of digital audio architectures. During AM reception, the TAS5508B adjusts the radiated emissions to provide an emission-clear zone for the tuned AM frequency. The inputs to the TAS5508B for this operation are the tuned AM frequency, the IF frequency, and the sample rate. The sample rate is automatically detected.

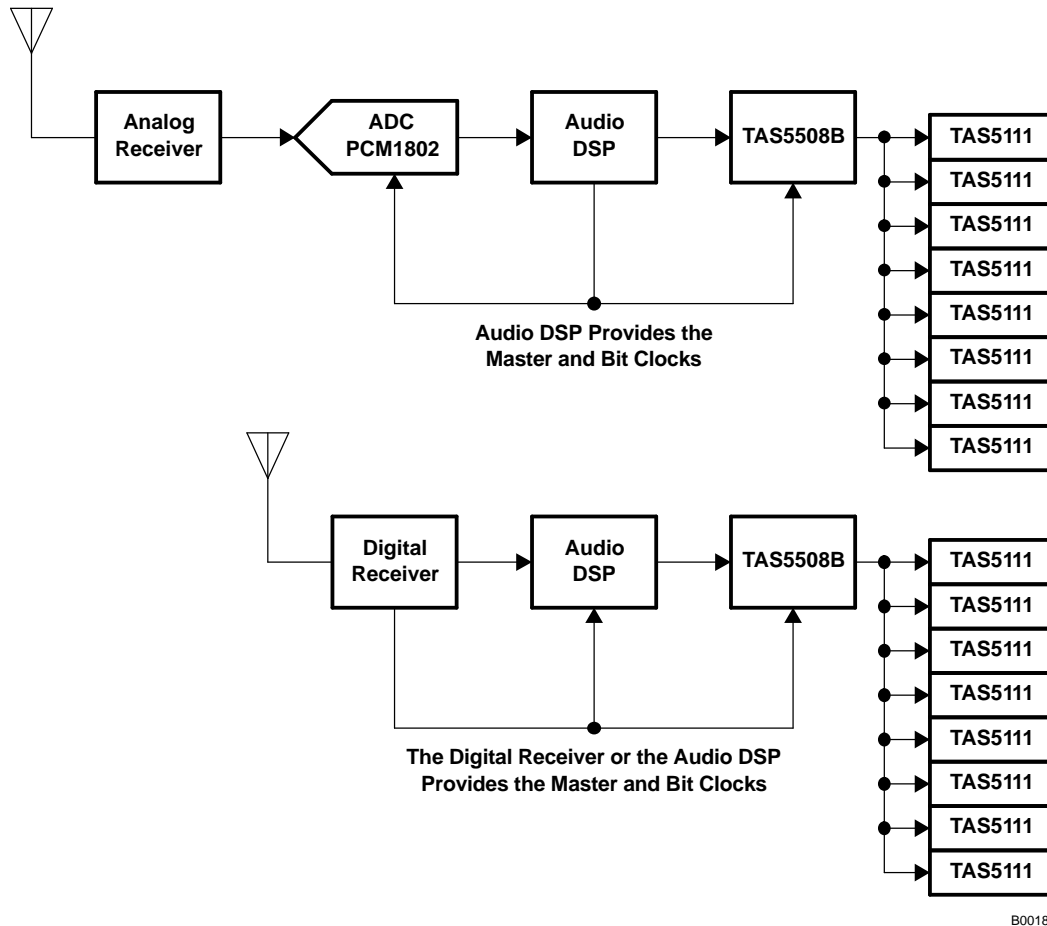

B0018-03

Figure 2-22. Block Diagrams of Typical Systems Requiring TAS5508B Automatic AM Interference-Avoidance Circuit

### 3 TAS5508B Controls and Status

The TAS5508B provides control and status information from both the I<sup>2</sup>C registers and device pins.

This section describes some of these controls and status functions. The I<sup>2</sup>C summary and detailed register descriptions are contained in [Section 6](#) and [Section 7](#).

#### 3.1 I<sup>2</sup>C Status Registers

The TAS5508B has two status registers that provide general device information. These are the general status register 0 (0x01) and the error status register (0x02).

##### 3.1.1 General Status Register (0x01)

- Device identification code
- Clip indicator – The TAS5508B has a clipping indicator. Writing to the register clears the indicator.

##### 3.1.2 Error Status Register (0x02)

- No internal errors (the valid signal is high)
- A clock error has occurred – These are sticky bits that are cleared by writing to the register.
  - LRCLK error – when the number of MCLKs per LRCLK is incorrect
  - SCLK error – when the number of SCLKs per LRCLK is incorrect
  - Frame slip – when the number of MCLKs per LRCLK changes by more than 10 MCLK cycles
  - PLL phase-lock error
- This error status register is normally used for system development only.

#### 3.2 TAS5508B Pin Controls

The TAS5508B provide a number of terminal controls to manage the device operation. These controls are:

- $\overline{\text{RESET}}$
- $\overline{\text{PDN}}$
- $\overline{\text{BKND\_ERR}}$
- $\overline{\text{HP\_SEL}}$
- $\overline{\text{MUTE}}$

##### 3.2.1 Reset ( $\overline{\text{RESET}}$ )

The TAS5508B is placed in the reset mode either by the power-up reset circuitry when power is applied, or by setting the  $\overline{\text{RESET}}$  terminal low.

$\overline{\text{RESET}}$  is an asynchronous control signal that restores the TAS5508B to the hard-mute state (M-state). Master volume is immediately set to full attenuation (there is no ramp down). Reset initiates the device reset without an MCLK input. As long as the  $\overline{\text{RESET}}$  terminal is held low, the device is in the reset state. During reset, all I<sup>2</sup>C and serial data bus operations are ignored.

[Table 3-1](#) shows the device output signals while  $\overline{\text{RESET}}$  is active.

**Table 3-1. Device Outputs During Reset**

| SIGNAL        | SIGNAL STATE              |
|---------------|---------------------------|
| Valid         | Low                       |
| PWM P-outputs | Low (M-state)             |
| PWM M-outputs | Low (M-state)             |
| SDA           | Signal input (not driven) |

Because  $\overline{\text{RESET}}$  is an asynchronous signal, clicks and pops produced during the application (the leading edge) of  $\overline{\text{RESET}}$  cannot be avoided. However, the transition from the hard-mute state (M-state) to the operational state is performed using a quiet start-up sequence to minimize noise. This control uses the PWM reset and unmute sequence to shut down and start up the PWM. A detailed description of these sequences is contained in the PWM section. If a completely quiet reset or power-down sequence is desired,  $\overline{\text{MUTE}}$  should be applied before applying  $\overline{\text{RESET}}$ .

The rising edge of the reset pulse begins device initialization before the transition to the operational mode. During device initialization, all controls are reset to their initial states. Table 3-2 shows the default control settings following a reset.

**Table 3-2. Values Set During Reset**

| <b>CONTROL</b>                                      | <b>SETTING</b>   |
|---|--|
| Output mixer configuration                          | 0xD0 bit 30 = 0 (remapped output mixer configuration)            |
| High pass   | Enabled  |
| Unmute from clock error                             | Hard unmute  |
| Input automute                                      | Enabled  |
| Output automute                                     | Enabled  |
| De-emphasis   | Disabled   |
| Serial data interface format                        | I <sup>2</sup> S, 24-bit   |
| Individual channel mute                             | No channels are muted  |
| Automute delay                                      | 5 ms   |
| Automute threshold 1                                | < 8 bits   |
| Automute threshold 2                                | Same as automute threshold 1                                     |
| Modulation limit                                    | 97.7% (Note: Some power stages require a lower modulation index) |
| Six- or eight-channel configuration                 | Eight channels   |
| Volume and mute update rate                         | Volume ramp 88.2 ms  |
| Treble and bass slew rate                           | Update every 1.31 ms   |
| Bank switching                                      | Manual bank selection is enabled                                 |
| Biquad coefficients                                 | Set to all pass  |
| Input mixer coefficients                            | Input N → Channel N, no attenuation                              |
| Output mixer coefficients                           | Channel N → Output N, no attenuation                             |
| Subwoofer sum into Ch1 and Ch2                      | Gain of 0  |
| Ch1 and Ch2 sum in subwoofer                        | Gain of 0  |
| Bass and treble bypass/inline                       | Bypass   |
| DRC bypass/inline                                   | Bypass   |
| DRC   | Default values   |
| Master volume                                       | Mute   |
| Individual channel volumes                          | 0 dB   |
| All bass and treble indexes                         | 0x12 neutral   |
| Treble filter sets                                  | Filter set 3   |
| Bass filter sets                                    | Filter set 3   |
| Loudness  | Loudness disabled, default values                                |
| AM interference mode enable                         | Disabled   |
| AM interference mode IF                             | 455 kHz  |
| AM interference mode select sequence                | 1  |
| AM interference mode tuned frequency and input mode | 0000, BCD  |

After the initialization time, the TAS5508B starts the transition to the operational state with the master volume set at mute.

Because the TAS5508B has an external crystal time base, following the release of reset, the TAS5508B sets the MCLK and data rates and performs the initialization sequences. The PWM outputs are held at a mute state until the master volume is set to a value other than mute via I<sup>2</sup>C.

### 3.2.2 Power Down ( $\overline{PDN}$ )

The TAS5508B can be placed into the power-down mode by holding the  $\overline{PDN}$  terminal low. When the power-down mode is entered, both the PLL and the oscillator are shut down. Volume is immediately set to full attenuation (there is no ramp down). This control uses the PWM mute sequence that provides a low click and pop transition to the hard-mute state (M-state).

Power down is an asynchronous operation that does not require MCLK to go into the power-down state. To initiate the power-up sequence requires MCLK to be operational and the TAS5508B to receive five MCLKs prior to the release of  $\overline{PDN}$ .

As long as the  $\overline{PDN}$  terminal is held low, the device is in the power-down state with the PWM outputs in a hard-mute state (M-state). During power down, all I<sup>2</sup>C and serial data bus operations are ignored. [Table 3-3](#) shows the device output signals while  $\overline{PDN}$  is active.

**Table 3-3. Device Outputs During Power Down**

| SIGNAL        | SIGNAL STATE  |
|---------------|---------------|
| VALID         | Low           |
| PWM P-outputs | M-state = low |
| PWM M-outputs | M-state = low |
| SDA           | Signal input  |
| PSVC          | M-state = low |

Following the application of  $\overline{PDN}$ , the TAS5508B does not perform a quiet shutdown to prevent clicks and pops produced during the application (the leading edge) of this command. The application of  $\overline{PDN}$  immediately performs a PWM stop. A quiet stop sequence can be performed by first applying  $\overline{MUTE}$  before  $\overline{PDN}$ .

When  $\overline{PDN}$  is released, the system goes to the end state specified by the  $\overline{MUTE}$  and  $\overline{BKND\_ERR}$  pins and the I<sup>2</sup>C register settings.

The crystal time base allows the TAS5508B to determine the CLK rates. Once these rates are determined, the TAS5508B unmutes the audio.

### 3.2.3 Back-End Error ( $\overline{BKND\_ERR}$ )

Back-end error is used to provide error management for back-end error conditions. Back-end error is a level-sensitive signal. Back-end error can be initiated by bringing the  $\overline{BKND\_ERR}$  terminal low for a minimum of five MCLK cycles. When  $\overline{BKND\_ERR}$  is brought low, the PWM sets either six or eight channels into the PWM back-end error state. This state is described in [Section 2.12](#). Once the back-end error sequence is initiated, a delay of 5 ms is performed before the system starts the output re-initialization sequence. After the initialization time, the TAS5508B begins normal operation. Back-end error does not affect other PWM modulator operations.

**Table 3-4. Device Outputs During Back-End Error**

| SIGNAL           | SIGNAL STATE              |
|------------------|---------------------------|
| Valid            | Low                       |
| PWM P-outputs    | M-state = low             |
| PWM M-outputs    | M-state = low             |
| PWM_HP P-outputs | M-state = low             |
| PWM_HP M-outputs | M-state = low             |
| SDA              | Signal input (not driven) |

### 3.2.3.1 $\overline{\text{BKND\_ERR}}$ and VALID

The number of channels that are affected by the  $\overline{\text{BKND\_ERR}}$  signal depends on the setting of bit D1 of I<sup>2</sup>C register 0xE0. If the I<sup>2</sup>C setting is 0 (8-channel mode), the TAS5508B places all eight PWM outputs in the PWM back-end error state. If the I<sup>2</sup>C setting is 1, the TAS5508B is in 6-channel mode. For proper operation in 6-channel mode, the lineout configuration registers (0x09 and 0x0A) must be 0x00 instead of the default of 0xE0. In this case, VALID is pulled LOW, and the TAS5508B brings PWM outputs 1, 2, 3, 4, 7, and 8 to a back-end error state, while not affecting lineout channels 5 and 6. Table 3-4 shows the device output signal states during back-end error.

### 3.2.4 Speaker/Headphone Selector ( $\overline{\text{HP\_SEL}}$ )

The  $\overline{\text{HP\_SEL}}$  terminal enables the headphone output or the speaker outputs. The headphone output receives the processed data output from DAP and PWM channels 1 and 2.

In 6-channel configuration, this feature does not affect the two lineout channels.

When low, the headphone output is enabled. In this mode, the speaker outputs are disabled. When high, the speaker outputs are enabled and the headphone is disabled.

Changes in the pin logic level result in a state change sequence using soft mute to the hard-mute state (M-state) for both speaker and headphone followed by a soft unmute.

When  $\overline{\text{HP\_SEL}}$  is low, the configuration of channels 1 and 2 is defined by the headphone configuration register. When  $\overline{\text{HP\_SEL}}$  is high, the channel-1 and -2 configuration registers define the configuration of channels 1 and 2.

If using the remapped-output mixer configuration (0xD0 bit 30 = 0) in the 6-channel mode, the headphone operation is modified. That is, following the assertion or de-assertion of headphone, mute must be asserted and de-asserted using the  $\overline{\text{MUTE}}$  pin.

### 3.2.5 Mute ( $\overline{\text{MUTE}}$ )

The mute control provides a noiseless volume ramp to silence. Releasing mute provides a noiseless ramp to previous volume. The TAS5508B has both master and individual channel mute commands. A terminal is also provided for the master mute. The active-low master mute I<sup>2</sup>C register and the  $\overline{\text{MUTE}}$  terminal are logically ORed together. If either is set to low, a mute on all channels is performed. The master mute command operates on all channels regardless of whether the system is in the 6- or 8-channel configuration.

When mute is invoked, the PWM output stops switching and then goes to an idle state.

The master mute terminal is used to support a variety of other operations in the TAS5508B, such as setting the the biquad coefficients, the serial interface format, and the clock rates. A mute command by the master mute terminal, individual I<sup>2</sup>C mute, the AM interference mute sequence, the bank-switch mute sequence, or automute overrides an unmute command or a volume command. While a mute is active, the commanded channels are placed in a mute state. When a channel is unmuted, it goes to the last commanded volume setting that has been received for that channel.



### 3.3 Device Configuration Controls

The TAS5508B provides a number of system configuration controls that are set at initialization and following a reset.

- Channel configuration
- Headphone configuration
- Audio system configurations
- Recovery from clock error
- Power-supply volume-control enable
- Volume and mute update rate
- Modulation index limit
- Master-clock and data-rate controls
- Bank controls

#### 3.3.1 Channel Configuration Registers

For the TAS5508B to have full control of the power stages, registers 0x05 to 0x0C must be programmed to reflect the proper power stage and how each one should be controlled. There are eight channel configuration registers, one for each channel. For information on using `BKND_ERR` and `VALID`, see [Section 3.2.3.1](#)

The primary reason for using these registers is that different power stages require different handling during start-up, mute/unmute, shutdown, and error recovery. The TAS5508B must select the sequence that gives the best click and pop performance and ensures that the bootstrap capacitor is charged correctly during start-up. This sequence depends on which power stage is present at the TAS5508B output.

**Table 3-5. Description of the Channel Configuration Registers (0x05 to 0x0C)**

| BIT | DESCRIPTION  |
|-----|--|
| D7  | Enable/disable error recovery sequence. In case the <code>BKND_ERR</code> pin is pulled low, this register determines if this channel is to follow the error recovery sequence or to continue with no interruption.  |
| D6  | Determines if the power stage needs the TAS5508B <code>VALID</code> pin to go low to reset the power stage. Some power stages can be reset by a combination of PWM signals. For these devices, it is recommended to set this bit low, because the <code>VALID</code> pin is shared for power stages. This provides better control of each power stage. |
| D5  | Determines if the power stage needs the TAS5508B <code>VALID</code> pin to go low to mute the power stage. Some power stages can be muted by a combination of PWM signals. For these devices, it is recommended to set this bit low, because the <code>VALID</code> pin is shared for power stages. This provides better control of each power stage.  |
| D4  | Inverts the PWM output. Inverting the PWM output can be an advantage if the power stage input pin is opposite the TAS5508B PWM pinout. This makes routing on the PCB easier. To keep the phase of the output, the speaker terminals must also be inverted.   |
| D3  | When using the TAS5182 power stage this bit must be set.   |
| D2  | Can be used to handle click and pop for some applications.   |
| D1  | This bit is normally used together with D2. For some power stages, both PWM signals must be high to get the desired operation of both speaker outputs to be low. This bit sets the PWM outputs high-high during mute.  |
| D0  | Not used   |

[Table 3-6](#) lists the optimal setting for each output-stage configuration. Note that the default value is applicable in all configurations except the TAS5182 SE/BTL configuration.

**Table 3-6. Recommended TAS5508B Configurations for Texas Instruments Power Stages**

| DEVICE               | ERROR RECOVERY | CONFIGURATION | D7 | D6 | D5 | D4 | D3 | D2 | D1 | D0 |
|----------------------|----------------|---------------|----|----|----|----|----|----|----|----|
| TAS5111<br>(default) | RES            | BTL           | 1  | 1  | 1  | 0  | 0  | 0  | 0  | 0  |
|                      |                | SE            | 1  | 1  | 1  | 0  | 0  | 0  | 0  | 0  |
|                      | AUT            | BTL           | 0  | 1  | 1  | 0  | 0  | 0  | 0  | 0  |
|                      |                | SE            | 0  | 1  | 1  | 0  | 0  | 0  | 0  | 0  |
| TAS5112              | RES            | BTL           | 1  | 1  | 0  | 0  | 0  | 0  | 0  | 0  |
|                      |                | SE            | 1  | 1  | 0  | 0  | 0  | 0  | 0  | 0  |
|                      | AUT            | BTL           | 0  | 1  | 0  | 0  | 0  | 0  | 0  | 0  |
|                      |                | SE            | 0  | 1  | 0  | 0  | 0  | 0  | 0  | 0  |
| TAS5182              | RES            | BTL           | 1  | 1  | 1  | 0  | 1  | 0  | 0  | 0  |
|                      |                | SE            | 1  | 1  | 1  | 0  | 1  | 0  | 0  | 0  |

RES: To recover from a shutdown, the output stage requires  $\overline{\text{VALID}}$  to go low.

AUT: The power stage can auto-recover from a shutdown.

BTL: Bridge-tied load configuration

SE: Single-ended configuration

### 3.3.2 Headphone Configuration Registers

The headphone configuration controls are identical to the speaker configuration controls. The headphone configuration control settings are used in place of the speaker configuration control settings for channels 1 and 2 when the headphones are selected. However, only one configuration setting for headphones is used, and that is the default setting.

### 3.3.3 Audio System Configurations

The TAS5508B can be configured to comply with various audio systems: 5.1-channel system, 6-channel system, 7.1-channel system, and 8-channel system.

The audio system configuration is set in the general control register (0xE0). Bits D31–D4 must be zero and D0 is *don't care*.

- D3 Must always be 0 (default). Note that subwoofer cannot be used as lineout when PSVC is enabled. (D3 is a write-only bit)
- D2 Enables/disables power-supply volume control
- D1 Sets number of speakers in the system, including possible line outputs

D3–D1 must be configured for the audio system in the application, as shown in [Table 3-7](#).

**Table 3-7. Audio System Configuration (General Control Register 0xE0)**

| Audio System                                      | D31–D4   | D3       | D2       | D1       | D0       |
|---|----------|----------|----------|----------|----------|
| 6 channels or 5.1 not using PSVC                  | 0        | 0        | 0        | 1        | X        |
| 6 channels using PSVC                             | 0        | 0        | 1        | 1        | X        |
| 5.1 system using PSVC                             | 0        | 0        | 1        | 1        | X        |
| <b>8 channels or 7.1 not using PSVC (default)</b> | <b>0</b> | <b>0</b> | <b>0</b> | <b>0</b> | <b>X</b> |
| 8 channels using PSVC                             | 0        | 0        | 1        | 0        | X        |
| 7.1 system using PSVC                             | 0        | 0        | 1        | 0        | X        |

### 3.3.3.1 Using Line Outputs in 6-Channel Configurations

The audio system can be configured for a 6-channel configuration (with 2 lineouts) by writing a 1 to bit D1 of register 0xE0 (general control register). In this configuration, channel-5 and -6 processing are exactly the same as the other channels, except that the master volume and the loudness function have no effect on the signal.

Note that in 6-channel configuration, channels 5 and 6 are unaffected by back-end error ( $\overline{\text{BKND\_ERR}}$  goes low).

To use channels 5 and 6 as unprocessed lineouts, the following setup is recommended:

- Channel-5 volume and channel-6 volume should be set for a constant output, such as 0 dB.
- Bass and treble for channels 5 and 6 can be used if desired.
- DRC1 should be bypassed for channels 5 and 6.
- If a down mix is desired on channels 5 and 6 as lineout, the down mixing can be performed using the channel-5 and channel-6 input mixers.
- The operation of the channel-5 and -6 biquads is unaffected by the 6-/8-channel configuration setting.

### 3.3.4 Recovery from Clock Error

The TAS5508B can be set either to perform a volume ramp up during the recovery sequence of a clock error or simply to come up in the last state (or desired state if a volume or tone update was in progress). This feature is enabled via I<sup>2</sup>C system control register 0x03.

### 3.3.5 Power-Supply Volume-Control Enable

The power-supply volume control (PSVC) can be enabled and disabled via I<sup>2</sup>C register 0xE0. The subwoofer PWM output is always controlled by the PSVC. When using PSVC the subwoofer cannot be used as lineout.

### 3.3.6 Volume and Mute Update Rate

The TAS5508B has fixed soft volume and mute ramp durations. The ramps are linear. The soft volume and mute ramp rates are adjustable by programming the I<sup>2</sup>C register 0xD0 for the appropriate number of steps to be 512, 1024, or 2048. The update is performed at a fixed rate regardless of the sample rate.

- In normal speed, the update rate is 1 step every  $4/f_s$  seconds.
- In double speed, the update is 1 step every  $8/f_s$  seconds.
- In quad speed, the update is 1 step every  $16/f_s$  seconds.

Because of processor loading, the update rate can increase for some increments by one step every  $1/f_s$  to  $3/f_s$ . However, the variance of the total time to go from 18 dB to mute is less than 25%.

**Table 3-8. Volume Ramp Periods in ms**

| NUMBER OF STEPS | SAMPLE RATE (kHz) |                 |
|-----------------|-------------------|-----------------|
|                 | 44.1, 88.2, 176.4 | 32, 48, 96, 192 |
| 512             | 46.44             | 42.67           |
| 1024            | 92.88             | 85.33           |
| 2048            | 185.76            | 170.67          |

### 3.3.7 Modulation Index Limit

PWM modulation is a linear function of the audio signal. When the audio signal is 0, the PWM modulation is 50%. When the audio signal increases toward full scale, the PWM modulation increases toward 100%. For negative signals, the PWM modulations fall below 50% toward 0%.

However, the maximum possible modulation does have a limit. During the offtime period, the power stage

connected to the TAS5508B output needs to get ready for the next on-time period. The maximum possible modulation is then set by the power stage requirements. The default modulation index limit setting is 97.7%; however, some power stages may require a lower modulation limit. See the applicable power stage data sheet for details on setting the modulation index limit. The default setting of 97.7% can be changed in the modulation index register (0x16).

### 3.4 Master Clock and Serial Data Rate Controls

The TAS5508B functions only as a receiver of the MCLK (master clock), SCLK (shift clock), and LRCLK (left/right clock) signals that control the flow of data on the four serial data interfaces. The 13.5-MHz external crystal allows the TAS5508B to detect MCLK and the data rate automatically.

The MCLK frequency can be  $64 f_s$ ,  $128 f_s$ ,  $196 f_s$ ,  $256 f_s$ ,  $384 f_s$ ,  $512 f_s$ , or  $768 f_s$ .

The TAS5508B operates with the serial data interface signals LRCLK and SCLK synchronized to MCLK. However, the phase relationship of these signals has no constraint. The TAS5508B accepts a  $64 f_s$  SCLK rate and a  $1 f_s$  LRCLK.

If the phase of SCLK or LRCLK drifts more than  $\pm 10$  MCLK cycles since the last reset, the TAS5508B senses a clock error and resynchronizes the clock timing.

The clock and serial data interface have several control parameters:

- MCLK ratio ( $64 f_s$ ,  $128 f_s$ ,  $196 f_s$ ,  $256 f_s$ ,  $384 f_s$ ,  $512 f_s$ , or  $768 f_s$ ) – I<sup>2</sup>C parameter
- Data rate (32, 38, 44.1, 48, 88.2, 96, 176.4, 192 kHz) – I<sup>2</sup>C parameter
- AM mode enable/disable – I<sup>2</sup>C parameter

During AM interference avoidance, the clock control circuitry uses three other configuration inputs:

- Tuned AM frequency (for AM interference avoidance) (550 kHz to 1750 kHz) – I<sup>2</sup>C parameter
- Frequency set select (1–4) – I<sup>2</sup>C parameter
- Sample rate – I<sup>2</sup>C parameter or auto-detected

#### 3.4.1 PLL Operation

The TAS5508B uses two internal clocks generated by two internal phase-locked loops (PLLs), the digital PLL (DPLL) and the analog PLL (APLL). The APLL provides the reference clock for the PWM. The DPLL provides the reference clock for the digital audio processor and the control logic.

The master clock MCLK input provides the input reference clock for the APLL. The external 13.5-MHz crystal provides the input reference clock for the DPLL. The crystal provides a time base to support a number of operations, including the detection of the MCLK ratio, the data rate, and clock error conditions. The crystal time base provides a constant rate for all controls and signal timing.

Even if MCLK is not present, the TAS5508B can receive and store I<sup>2</sup>C commands and provide status.

### 3.5 Bank Controls

The TAS5508B permits the user to specify and assign sample-rate-dependent parameters for biquad, loudness, DRC, and tone in one of three banks that can be manually selected or selected automatically based on the data sampling rate. Each bank can be enabled for one or more specific sample rates via I<sup>2</sup>C bank control register 0x40. Each bank set holds the following values:

- Coefficients for seven biquads ( $7 \times 5 = 35$  coefficients) for each of the eight channels (registers 0x51–0x88)
- Coefficients for one loudness biquad (register 0x95)
- DRC1 energy and (1 – energy) values (register 0x98)
- DRC1 attack, (1 – attack), decay, (1 – decay) values (register 0x9C)
- DRC2 energy and (1 – energy) values (register 0x9D)
- DRC2 attack, (1 – attack), decay, (1 – decay) values (register 0xA1)

- Five bass filter-set selections (register 0xDA)
- Five treble filter-set selections (register 0xDC)

The default selection for bank control is manual bank with bank 1 selected. Note that if bank switching is used, bank 2 and bank 3 must be programmed on power up, because the default values are all zeroes. If bank switching is used and bank 2 and bank 3 are not programmed correctly, then the output of the TAS5508B could be muted when switching to those banks.

### 3.5.1 Manual Bank Selection

The three bank-selection bits of the bank control register allow the appropriate bank to be manually selected (000 = bank 1, 001 = bank 2, 010 = bank 3). In the manual mode, when a write occurs to the biquad, DRC, or loudness coefficients, the currently selected bank is updated. If audio data is streaming to the TAS5508B during a manual bank selection, the TAS5508B first performs a mute sequence, then performs the bank switch, and finally restores the volume using an unmute sequence.

A mute command initiated by the bank-switch mute sequence overrides an unmute command or a volume command. While a mute is active, the commanded channels are muted. When a channel is unmuted, the volume level goes to the last commanded volume setting that has been received for that channel.

If MCLK or SCLK is stopped, the TAS5508B performs a bank-switch operation. If the clocks start up once the manual bank-switch command has been received, the bank-switch operation is performed during the 5-ms, silent-start sequence.

### 3.5.2 Automatic Bank Selection

To enable automatic bank selection, a value of 3 is written into the bank-selection bits of the bank control register. Banks are associated with one or more sample rates by writing values into the bank 1 or bank 2 data-rate selection registers. The automatic bank selection is performed when a frequency change is detected according to the following scheme:

1. The system scans bank-1 data-rate associations to see if bank 1 is assigned for that data rate.
2. If bank 1 is assigned, then the bank-1 coefficients are loaded.
3. If bank 1 is not assigned, the system scans bank 2 to see if bank 2 is assigned for that data rate.
4. If bank 2 is assigned, the bank-2 coefficients are loaded.
5. If bank 2 is not assigned, the system loads the bank-3 coefficients.

The default is that all frequencies are enabled for bank 1. This default is expressed as a value of all 1s in the bank-1 auto-selection byte and all 0s in the bank-2 auto-selection byte.

#### 3.5.2.1 Coefficient Write Operations While Automatic Bank Switch Is Enabled

In automatic mode, if a write occurs to the tone, EQ, DRC, or loudness coefficients, the bank that is written to is the current bank.

### 3.5.3 Bank Set

Bank set is used to provide a secure way to update the bank coefficients in both the manual and automatic switching modes without causing a bank switch to occur. Bank-set mode does not alter the current bank register mapping. It simply enables any bank coefficients to be updated while inhibiting any bank switches from taking place. In manual mode, this enables the coefficients to be set without switching banks. In automatic mode, this prevents a clock error or data-rate change from corrupting a bank coefficient write.

To update the coefficients of a bank, a value of 4, 5, or 6 is written into in the bank-selection bits of the bank control register. This enables the tone, EQ, DRC, and loudness coefficient values of bank 1, 2, or 3, respectively, to be updated.

Once the coefficients of the bank have been updated, the bank-selection bits are then returned to the desired manual or automatic bank-selection mode.

### 3.5.4 Bank-Switch Timeline

After a bank switch is initiated (manual or automatic), no I<sup>2</sup>C writes to the TAS5508B should occur before a minimum of 186 ms. This value is determined by the volume ramp rates for a particular sample rate.

### 3.5.5 Bank-Switching Example 1

**Problem:** The audio unit containing a TAS5508B needs to handle different audio formats with different sample rates. Format #1 requires  $f_s = 32$  kHz, format #2 requires  $f_s = 44.1$  kHz, and format #3 requires  $f_s = 48$  kHz. The sample-rate-dependent parameters in the TAS5508B require different coefficients and data depending on the sample rate.

**Strategy:** Use the TAS5508B bank-switching feature to allow for managing and switching three banks associated with the three sample rates, 32 kHz (bank 1), 44.1 kHz (bank 2), and 48 kHz (bank 3).

One possible algorithm is to generate, load, and automatically manage bank switching for this problem:

1. Generate bank-related coefficients for sample rates of 32 kHz, 44.1 kHz, and 48 kHz, and include the same in the microprocessor-based TAS5508B I<sup>2</sup>C firmware.
2. On TAS5508B power up or reset, the microprocessor runs the following TAS5508B initialization code:
  - a. Update bank 1 (write 0x0004 8040 to register 0x40).
  - b. Write bank-related I<sup>2</sup>C registers with appropriate values for bank 1.
  - c. Write bank 2 (write 0x0005 8040 to register 0x40).
  - d. Load bank-related I<sup>2</sup>C registers with appropriate values for bank 2.
  - e. Write bank 3 (write 0x0006 8040 to register 0x40).
  - f. Load bank-related I<sup>2</sup>C registers with appropriate values for bank 3.
  - g. Select automatic bank switching (write 0x0003 8040 to register 0x40).
3. When the audio media changes, the TAS5508B automatically detects the incoming sample rate and automatically switches to the appropriate bank.

In this example, any sample rates other than 32 kHz and 44.1 kHz use bank 3. If other sample rates are used, then the banks must be set up differently.

### 3.5.6 Bank-Switching Example 2

**Problem:** The audio system uses all of the sample rates supported by the TAS5508B. How can the automatic bank switching be set up to handle this situation?

**Strategy:** Use the TAS5508B bank-switching feature to allow for managing and switching three banks associated with sample rates as follows:

- Bank 1: Coefficients for 32 kHz, 38 kHz, 44.1 kHz, and 48 kHz
- Bank 2: Coefficients for 88.2 kHz and 96 kHz
- Bank 3: Coefficients for 176.4 kHz and 192 kHz

One possible algorithm is to generate, load, and automatically manage bank switching for this problem:

1. Generate bank-related coefficients for sample rates 48 kHz (bank 1), 96 kHz (bank 2), and 192 kHz (bank 3) and include the same in the microprocessor-based TAS5508B I<sup>2</sup>C firmware.
2. On TAS5508B power up or reset, the microprocessor runs the following TAS5508B initialization code:
  - a. Update bank 1 (write 0x0004 F00C to register 0x40).
  - b. Write bank-related I<sup>2</sup>C registers with appropriate values for bank 1.
  - c. Write bank 2 (write 0x0005 F00C to register 0x40).
  - d. Load bank-related I<sup>2</sup>C registers with appropriate values for bank 2.
  - e. Write bank 3 (write 0x0006 F00C to register 0x40).
  - f. Load bank-related I<sup>2</sup>C registers with appropriate values for bank 3.
  - g. Select automatic bank switching (write 0x0003 F00C to register 0x40).
3. When the audio media changes, the TAS5508B automatically detects the incoming sample rate and automatically switches to the appropriate bank.

## 4 Electrical Specifications

### 4.1 Absolute Maximum Ratings<sup>(1)</sup>

|                                  |   |                                       |
|----------------------------------|---|---------------------------------------|
| Supply voltage, DVDD and DVD_PWM |   | –0.3 V to 3.6 V                       |
| Supply voltage, AVDD_PLL         |   | –0.3 V to 3.6 V                       |
| Input voltage                    | 3.3-V digital input   | –0.5 V to DVDD + 0.5 V                |
|                                  | 5-V tolerant <sup>(2)</sup> digital input                           | –0.5 V to 6 V                         |
|                                  | 1.8-V LVCMOS <sup>(3)</sup>   | –0.5 V to VREF <sup>(4)</sup> + 0.5 V |
| I <sub>IK</sub>                  | Input clamp current (V <sub>I</sub> < 0 or V <sub>I</sub> > 1.8 V)  | ±20 µA                                |
| I <sub>OK</sub>                  | Output clamp current (V <sub>O</sub> < 0 or V <sub>O</sub> > 1.8 V) | ±20 µA                                |
| T <sub>A</sub>                   | Operating free-air temperature                                      | 0°C to 70°C                           |
| T <sub>stg</sub>                 | Storage temperature range   | –65°C to 150°C                        |

- (1) Stresses beyond those listed under "absolute maximum ratings" may cause permanent damage to the device. These are stress ratings only, and functional operation of the device at these or any other conditions beyond those indicated under "recommended operating conditions" is not implied. Exposure to absolute-maximum-rated conditions for extended periods may affect device reliability.
- (2) 5-V tolerant inputs are RESET, PDN, MUTE, HP\_SEL, SCLK, LRCLK, MCLK, SDIN1, SDIN2, SDIN3, SDIN4, SDA, and SCL.
- (3) VRA\_PLL, VRD\_PLL, VR\_DPLL, VR\_DIG, VR\_PWM
- (4) VREF is a 1.8-V supply derived from regulators internal to the TAS5508B chip. VREF is on terminals VRA\_PLL, VRD\_PLL, VR\_DPLL, VR\_DIG, and VR\_PWM. These terminals are provided to permit use of external filter capacitors, but should not be used to source power to external devices.

### 4.2 Dissipation Rating Table (High-k Board, 105°C Junction)

| PACKAGE | T <sub>A</sub> ≤ 25°C<br>POWER RATING | DERATING FACTOR<br>ABOVE T <sub>A</sub> = 25°C | T <sub>A</sub> = 70°C<br>POWER RATING |
|---------|---------------------------------------|--|---------------------------------------|
| PAG     | 1869 mW                               | 23.36 mW/°C                                    | 818 mW                                |

### 4.3 Dynamic Performance at Recommended Operating Conditions at 25°C

| PARAMETER                 | TEST CONDITIONS   | MIN | NOM   | MAX | UNIT |
|---------------------------|---|-----|-------|-----|------|
| Dynamic range             | TAS5508B + TAS5111 A-weighted (f <sub>S</sub> = 48 kHz) |     | 102   |     | dB   |
| Total harmonic distortion | TAS5111 at 1 W  |     | 0.1%  |     |      |
|                           | TAS5508B output   |     | 0.01% |     |      |
| Frequency response        | 32-kHz to 96-kHz sample rates                           |     | ±0.1  |     | dB   |
|                           | 176.4, 192-kHz sample rates                             |     | ±0.2  |     |      |

### 4.4 Recommended Operating Conditions

|   |   | MIN                         | NOM  | MAX  | UNIT |
|---|---|-----------------------------|------|------|------|
| Digital supply voltage, DVDD and DVDD_PWM |   | 3                           | 3.3  | 3.6  | V    |
| Analog supply voltage, AVDD_PLL           |   | 3                           | 3.3  | 3.6  | V    |
| V <sub>IH</sub>                           | High-level input voltage                | 3.3 V                       | 2    |      | V    |
|   |   | 5-V tolerant <sup>(1)</sup> | 2    |      |      |
|   |   | 1.8-V LVCMOS (XTL_IN)       | 1.26 |      |      |
| V <sub>IL</sub>                           | Low-level input voltage                 | 3.3 V                       |      | 0.8  | V    |
|   |   | 5-V tolerant <sup>(1)</sup> |      | 0.8  |      |
|   |   | 1.8-V (XTL_IN)              |      | 0.54 |      |
| T <sub>A</sub>                            | Operating ambient-air temperature range | 0                           | 25   | 70   | °C   |
| T <sub>J</sub>                            | Operating junction temperature range    | 0                           |      | 105  | °C   |

- (1) 5-V tolerant inputs are RESET, PDN, MUTE, HP\_SEL, SCLK, LRCLK, MCLK, SDIN1, SDIN2, SDIN3, SDIN4, SDA, and SCL.

## 4.5 Electrical Characteristics

Over recommended operating conditions (unless otherwise noted)

| PARAMETER       |                               | TEST CONDITIONS                           | MIN                                | TYP  | MAX | UNIT |
|-----------------|-------------------------------|---|------------------------------------|------|-----|------|
| V <sub>OH</sub> | High-level output voltage     | 3.3-V TTL and 5-V <sup>(1)</sup> tolerant | I <sub>OH</sub> = -4 mA            | 2.4  |     | V    |
|                 |                               | 1.8-V LVCMOS (XTL_OUT)                    | I <sub>OH</sub> = -0.55 mA         | 1.44 |     |      |
| V <sub>OL</sub> | Low-level output voltage      | 3.3-V TTL and 5-V <sup>(1)</sup> tolerant | I <sub>OL</sub> = 4 mA             |      | 0.5 | V    |
|                 |                               | 1.8-V LVCMOS (XTL_OUT)                    | I <sub>OL</sub> = 0.75 mA          |      | 0.5 |      |
| I <sub>OZ</sub> | High-impedance output current | 3.3-V TTL                                 |                                    |      | ±20 | μA   |
| I <sub>IL</sub> | Low-level input current       | 3.3-V TTL                                 | V <sub>I</sub> = V <sub>IL</sub>   |      | ±1  | μA   |
|                 |                               | 1.8-V LVCMOS (XTL_IN)                     | V <sub>I</sub> = V <sub>IL</sub>   |      | ±1  |      |
|                 |                               | 5-V tolerant <sup>(2)</sup>               | V <sub>I</sub> = 0 V, DVDD = 3 V   |      | ±1  |      |
| I <sub>IH</sub> | High-level input current      | 3.3-V TTL                                 | V <sub>I</sub> = V <sub>IH</sub>   |      | ±1  | μA   |
|                 |                               | 1.8-V LVCMOS (XTL_IN)                     | V <sub>I</sub> = V <sub>IH</sub>   |      | ±1  |      |
|                 |                               | 5-V tolerant <sup>(2)</sup>               | V <sub>I</sub> = 5.5 V, DVDD = 3 V |      | ±20 |      |
| I <sub>DD</sub> | Input supply current          | Digital supply voltage, DVDD              | f <sub>S</sub> = 48 kHz            |      | 140 | mA   |
|                 |                               |   | f <sub>S</sub> = 96 kHz            |      | 150 |      |
|                 |                               |   | f <sub>S</sub> = 192 kHz           |      | 155 |      |
|                 |                               |   | Power down                         |      | 8   |      |
|                 |                               | Analog supply voltage, AVDD               | Normal                             |      | 20  |      |
|                 |                               |   | Power down                         |      | 2   |      |

(1) 5-V tolerant outputs are SCL and SDA.

(2) 5-V tolerant inputs are RESET, PDN, MUTE, HP\_SEL, SCLK, LRCLK, MCLK, SDIN1, SDIN2, SDIN3, SDIN4, SDA, and SCL.

## 4.6 PWM Operation

Over recommended operating conditions

| PARAMETER                            | TEST CONDITIONS                       | MODE                      | VALUE | UNIT |
|--------------------------------------|---------------------------------------|---------------------------|-------|------|
| Output sample rate 1×–8× oversampled | 32-kHz data rate ±2%                  | 12× sample rate           | 384   | kHz  |
|                                      | 44.1-, 88.2-, 176.4-kHz data rate ±2% | 8×, 4×, or 2× sample rate | 352.8 |      |
|                                      | 48-, 96-, 192-kHz data rate ±1%       | 8×, 4×, or 2× sample rate | 384   |      |

## 4.7 Switching Characteristics

### 4.7.1 Clock Signals

PLL input parameters and external filter components over recommended operating conditions (unless otherwise noted)<sup>(1)</sup>

| PARAMETER          |  | TEST CONDITIONS   | MIN | TYP  | MAX | UNIT  |
|--------------------|--|---|-----|------|-----|-------|
| f <sub>XTALI</sub> | Frequency, XTAL IN                         | Only use 13.5-MHz crystal ≤1000 ppm                                     |     | 13.5 |     | MHz   |
| f <sub>MCLKI</sub> | Frequency, MCLK (1/t <sub>cyc2</sub> )     |   | 2   |      | 50  | MHz   |
|                    | MCLK duty cycle                            |   | 40% | 50%  | 60% |       |
|                    | MCLK minimum high time                     | ≥2-V MCLK = 49.152 MHz, within the min and max duty cycle constraints   | 5   |      |     | ns    |
|                    | MCLK minimum low time                      | ≤0.8-V MCLK = 49.152 MHz, within the min and max duty cycle constraints | 5   |      |     | ns    |
|                    | LRCLK allowable drift before LRCLK reset   |   | -10 |      | 10  | MCLKs |
|                    | External PLL filter capacitors C11 and C12 | SMD 0603 Y5V  |     | 100  |     | nF    |
|                    | External PLL filter capacitors C10 and C13 | SMD 0603 Y5V  |     | 10   |     | nF    |
|                    | External PLL filter resistors R10 and R11  | SMD 0603, metal film  |     | 200  |     | Ω     |
|                    | External VRA_PLL decoupling C14            | SMD, Y5V  |     | 100  |     | nF    |

(1) See the *TAS5508B Example Application Schematic*, Section 8.



### 4.7.2 Serial Audio Port

Serial audio port slave mode over recommended operating conditions (unless otherwise noted)

| PARAMETER    |   | TEST CONDITIONS                         | MIN   | TYP | MAX    | UNIT        |
|--------------|---|---|-------|-----|--------|-------------|
| $f_{SCLKIN}$ | SCLK input frequency                                      | $C_L = 30 \text{ pF}$ , $SCLK = 64 f_S$ | 2.048 |     | 12.288 | MHz         |
| $t_{su1}$    | Setup time, LRCLK to SCLK rising edge                     |   | 10    |     |        | ns          |
| $t_{h1}$     | Hold time, LRCLK from SCLK rising edge                    |   | 10    |     |        | ns          |
| $t_{su2}$    | Setup time, SDIN to SCLK rising edge                      |   | 10    |     |        | ns          |
| $t_{h2}$     | Hold time, SDIN from SCLK rising edge                     |   | 10    |     |        | ns          |
|              | LRCLK frequency   |   | 32    | 48  | 192    | kHz         |
|              | SCLK duty cycle   |   | 40%   | 50% | 60%    |             |
|              | LRCLK duty cycle  |   | 40%   | 50% | 60%    |             |
|              | SCLK rising edges between LRCLK rising edges              |   | 64    |     | 64     | SCLK edges  |
|              | LRCLK clock edge with respect to the falling edge of SCLK |   | -1/4  |     | 1/4    | SCLK period |

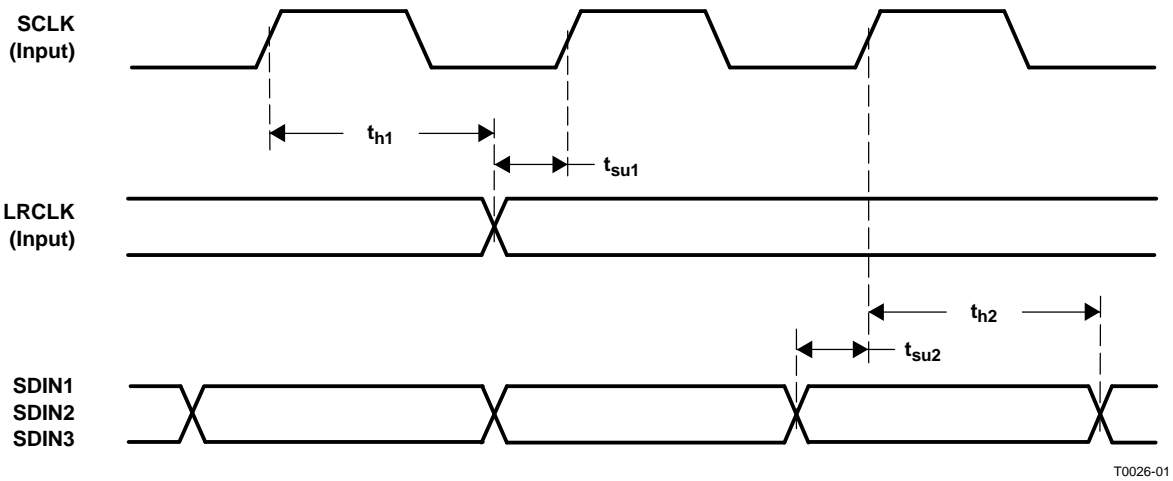

T0026-01

Figure 4-1. Slave Mode Serial Data Interface Timing

### 4.7.3 TAS5508B Pin-Related Characteristics of the SDA and SCL I/O Stages for F/S-Mode I<sup>2</sup>C-Bus Devices

| PARAMETER | TEST CONDITIONS   | STANDARD MODE                        |              | FAST MODE           |                   | UNIT          |
|-----------|---|--------------------------------------|--------------|---------------------|-------------------|---------------|
|           |   | MIN                                  | MAX          | MIN                 | MAX               |               |
| $V_{IL}$  | LOW-level input voltage                                 | -0.5                                 | $0.3 V_{DD}$ | -0.5                | $0.3 V_{DD}$      | V             |
| $V_{IH}$  | HIGH-level input voltage                                | $0.7 V_{DD}$                         |              | $0.7 V_{DD}$        |                   | V             |
| $V_{hys}$ | Hysteresis of Schmitt-trigger inputs                    | N/A                                  | N/A          | $0.05 V_{DD}$       |                   | V             |
| $V_{OL1}$ | LOW-level output voltage (open drain or open collector) | 3-mA sink current                    |              | 0                   | 0.4               | V             |
| $t_{of}$  | Output fall time from $V_{IHmin}$ to $V_{ILmax}$        | Bus capacitance from 10 pF to 400 pF |              | $7 + 0.1 C_b^{(1)}$ | 250               | ns            |
| $t_{SP}$  | Pulse duration of spikes suppressed <sup>(2)</sup>      | N/A                                  | N/A          | 0                   | 30                | ns            |
| $I_i$     | Input current, each I/O pin                             | -30                                  | 30           | -30 <sup>(3)</sup>  | 30 <sup>(3)</sup> | $\mu\text{A}$ |
| $C_i$     | Capacitance, each I/O pin                               |                                      |              | 10                  | 10                | pF            |

(1)  $C_b$  = capacitance of one bus line in pF. The output fall time is faster than the standard I<sup>2</sup>C specification.

(2) SCL and SDA have a 30-ns glitch filter.

(3) The I/O pins of fast-mode devices must not obstruct the SDA and SDL lines if  $V_{DD}$  is switched off.

#### 4.7.4 TAS5508B Bus-Related Characteristics of the SDA and SCL I/O Stages for F/S-Mode I<sup>2</sup>C-Bus Devices

All values are referred to  $V_{IHmin}$  and  $V_{ILmax}$  (see Section 4.7.3).

| PARAMETER    | TEST CONDITIONS  | STANDARD MODE |      | FAST MODE            |             | UNIT    |
|--------------|--|---------------|------|----------------------|-------------|---------|
|              |  | MIN           | MAX  | MIN                  | MAX         |         |
| $f_{SCL}$    | SCL clock frequency  | 0             | 100  | 0                    | 400         | kHz     |
| $t_{HD-STA}$ | Hold time (repeated) START condition. After this period, the first clock pulse is generated. | 4             |      | 0.6                  |             | $\mu$ s |
| $t_{LOW}$    | LOW period of the SCL clock  | 4.7           |      | 1.3                  |             | $\mu$ s |
| $t_{HIGH}$   | HIGH period of the SCL clock   | 4             |      | 0.6                  |             | $\mu$ s |
| $t_{SU-STA}$ | Setup time for repeated START  | 4.7           |      | 0.6                  |             | $\mu$ s |
| $t_{SU-DAT}$ | Data setup time  | 250           |      | 100                  |             | $\mu$ s |
| $t_{HD-DAT}$ | Data hold time <sup>(1)(2)</sup>   | 0             | 3.45 | 0                    | 0.9         | $\mu$ s |
| $t_r$        | Rise time of both SDA and SCL  |               | 1000 | $20 + 0.1 C_b^{(3)}$ | $500^{(4)}$ | ns      |
| $t_f$        | Fall time of both SDA and SCL  |               | 300  | $20 + 0.1 C_b^{(3)}$ | 300         | ns      |
| $t_{SU-STO}$ | Setup time for STOP condition  | 4             |      | 0.6                  |             | $\mu$ s |
| $t_{BUF}$    | Bus free time between a STOP and START condition   | 4.7           |      | 1.3                  |             | $\mu$ s |
| $C_b$        | Capacitive loads for each bus line   |               | 400  |                      | 400         | pF      |
| $V_{NL}$     | Noise margin at the LOW level for each connected device (including hysteresis)               | 0.1 $V_{DD}$  |      | 0.1 $V_{DD}$         |             | V       |
| $V_{NH}$     | Noise margin at the HIGH level for each connected device (including hysteresis)              | 0.2 $V_{DD}$  |      | 0.2 $V_{DD}$         |             | V       |

- (1) Note that SDA does not have the standard I<sup>2</sup>C specification 300-ns hold time and that SDA must be valid by the rising and falling edges of SCL. TI recommends that a 3.3-k $\Omega$  pullup resistor be used to avoid potential timing issues.
- (2) A fast-mode I<sup>2</sup>C-bus device can be used in a standard-mode I<sup>2</sup>C-bus system, but the requirement  $t_{SU-DAT} \geq 250$  ns must then be met. This is automatically the case if the device does not stretch the LOW period of the SCL signal. If such a device does stretch the LOW period of the SCL signal, it must output the next data bit to the SDA line  $t_{r-max} + t_{SU-DAT} = 1000 + 250 = 1250$  ns (according to the standard-mode I<sup>2</sup>C bus specification) before the SCL line is released.
- (3)  $C_b$  = total capacitance of one bus line in pF.
- (4) Rise time varies with pullup resistor.

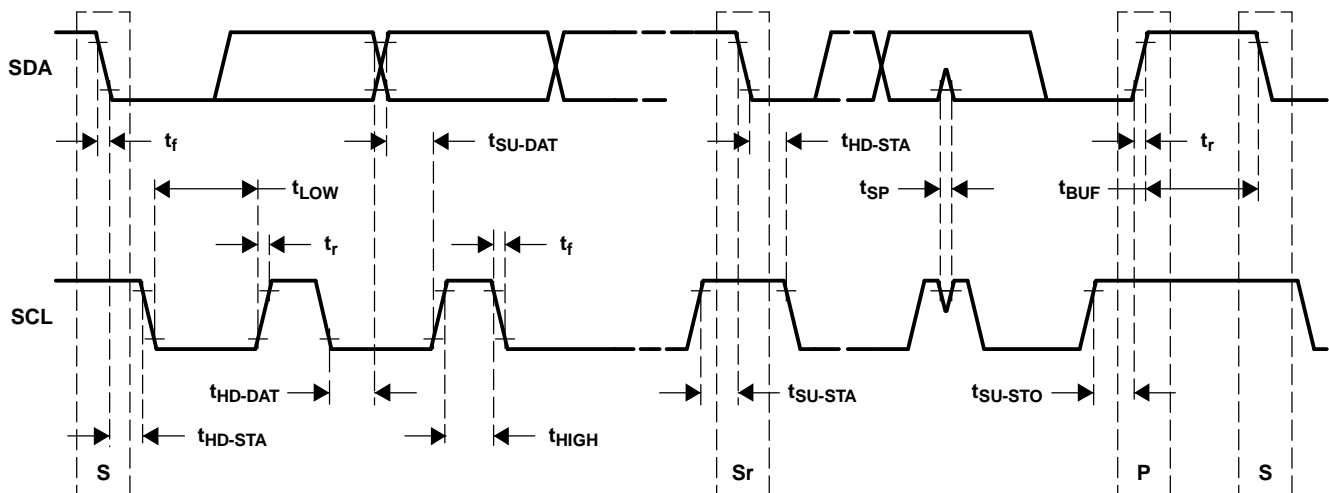

T0114-01

Figure 4-2. Start and Stop Conditions Timing Waveforms

#### 4.7.4.1 Recommended I<sup>2</sup>C Pullup Resistors

It is recommended that the I<sup>2</sup>C pullup resistors  $R_P$  be 3.3 k $\Omega$  (see Figure 4-3). If a series resistor is in the circuit (see Figure 4-4), then the series resistor  $R_S$  should be less than or equal to 300  $\Omega$ .

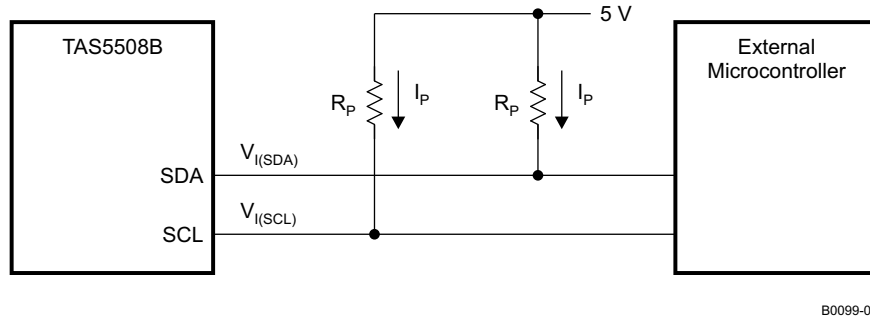

**Figure 4-3. I<sup>2</sup>C Pullup Circuit (With No Series Resistor)**

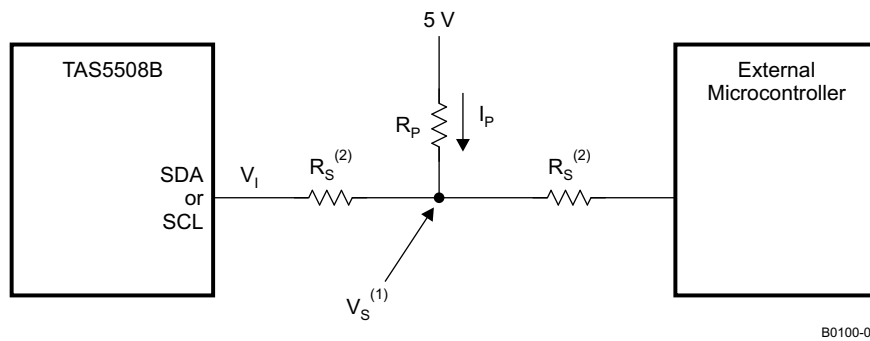

- (1)  $V_S = 5 \times R_S / (R_S = R_P)$ . When driven low,  $V_S \ll V_{IL}$  requirements.
- (2)  $R_S \leq 300 \Omega$

**Figure 4-4. I<sup>2</sup>C Pullup Circuit (With Series Resistor)**

### 4.7.5 Reset Timing ( $\overline{RESET}$ )

Control signal parameters over recommended operating conditions (unless otherwise noted)

| PARAMETER  | MIN | TYP | MAX | UNIT |
|--|-----|-----|-----|------|
| $t_{d(PWM\_off)}$ Time from reset to PWM_EN low (PWM outputs disabled) |     |     | 370 | ns   |
| $t_w(RESET)$ Pulse duration, $\overline{RESET}$ active                 | 400 |     |     | ns   |
| $t_{d(I2C\_ready)}$ Time to enable I <sup>2</sup> C                    |     | 3   |     | ms   |
| $t_{d(run)}$ Device start-up time                                      | 10  |     |     | ms   |

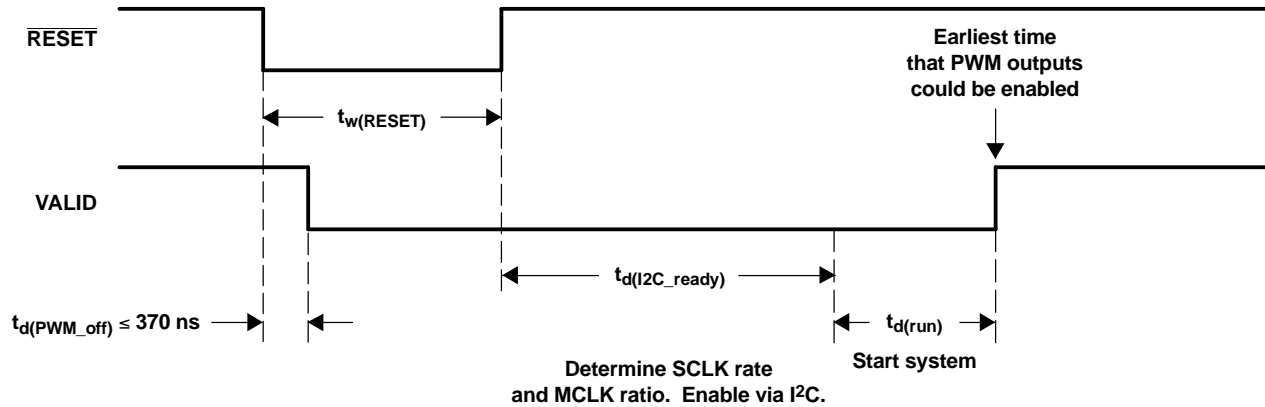

T0029-04

NOTE: Because a crystal time base is used, the system determines the CLK rates. Once the data rate and master clock ratio is determined, the system outputs audio if a master volume command is issued at the beginning of  $t_{d(run)}$ .

Figure 4-5. Reset Timing

### 4.7.6 Power-Down ( $\overline{PDN}$ ) Timing

Control signal parameters over recommended operating conditions (unless otherwise noted)

| PARAMETER  | MIN | TYP | MAX | UNIT    |
|--|-----|-----|-----|---------|
| $t_{d(PWM\_off)}$ Time from reset to PWM_EN low (PWM outputs disabled) |     |     | 300 | $\mu$ s |
| Number of MCLKs preceding the release of $\overline{PDN}$              | 5   |     |     |         |
| $t_{su}$ Device start-up time  |     | 120 |     | ms      |

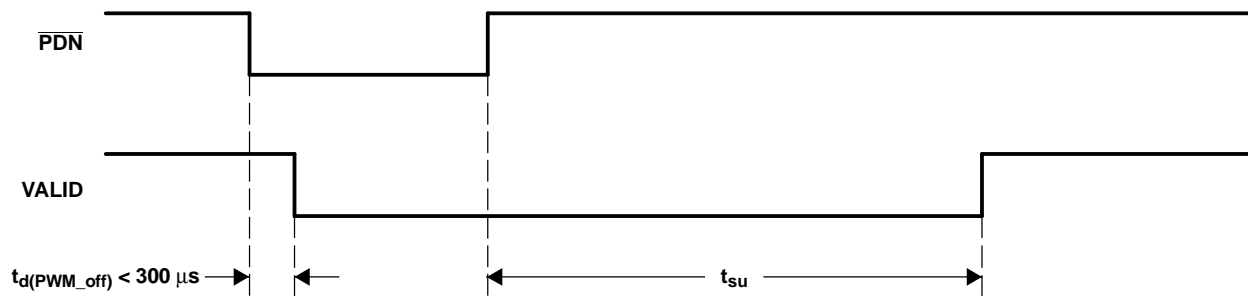

T0030-03

Figure 4-6. Power-Down Timing

#### 4.7.7 Back-End Error ( $\overline{BKND\_ERR}$ )

Control signal parameters over recommended operating conditions (unless otherwise noted)

| PARAMETER            |   | MIN | TYP | MAX  | UNIT          |
|----------------------|---|-----|-----|------|---------------|
| $t_{w(ER)}$          | Pulse duration, $\overline{BKND\_ERR}$ active                 | 350 |     | None | ns            |
| $t_{d(valid\_low)}$  | Time from back-end error to PWM_EN low (PWM outputs disabled) |     |     | 100  | $\mu$ s       |
| $t_{d(valid\_high)}$ | I <sup>2</sup> C programmable to be between 1 to 10 ms        | -25 |     | 25   | % of interval |

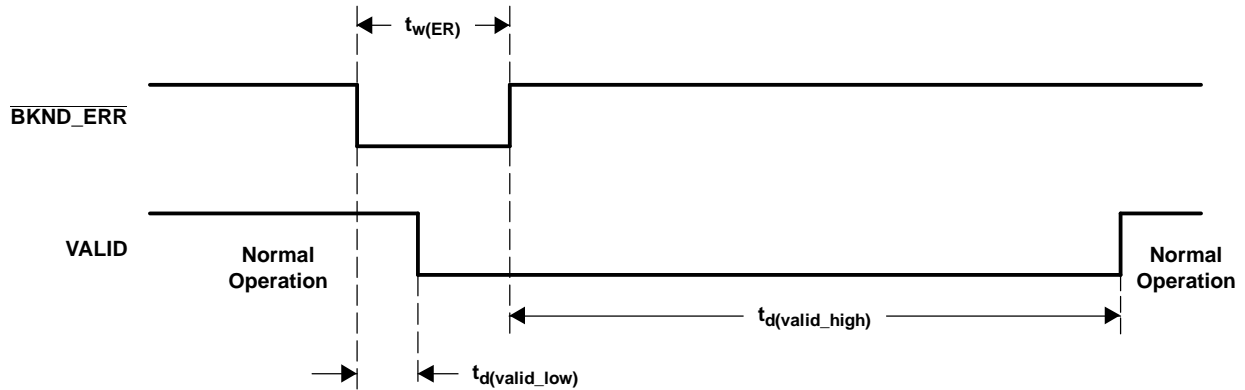

T0031-03

Figure 4-7. Error-Recovery Timing

#### 4.7.8 Mute Timing ( $\overline{MUTE}$ )

Control signal parameters over recommended operating conditions (unless otherwise noted)

| PARAMETER    |                  | MIN                                    | TYP | MAX | UNIT |
|--------------|------------------|--|-----|-----|------|
| $t_{d(VOL)}$ | Volume ramp time | Defined by rate setting <sup>(1)</sup> |     |     | ms   |

(1) See the *Volume, Treble, and Base Slew Rates Register (0xD0)*, [Section 7.26](#).

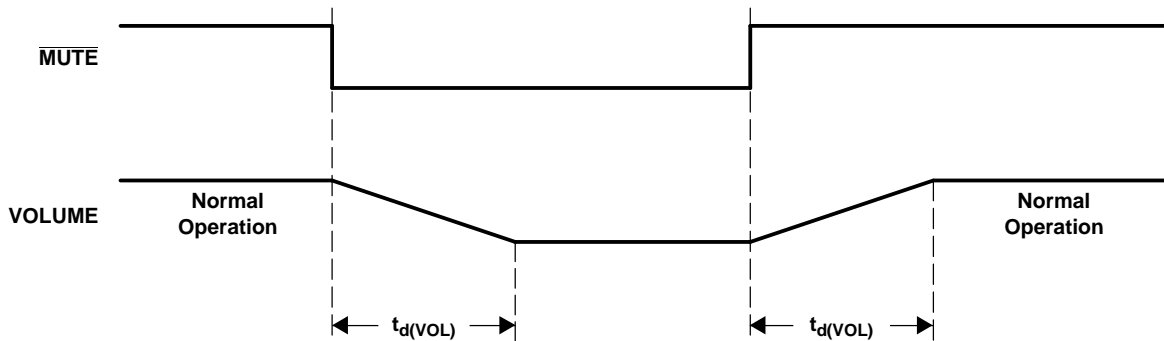

T0032-02

Figure 4-8. Mute Timing

### 4.7.9 Headphone Select ( $\overline{HP\_SEL}$ )

Control signal parameters over recommended operating conditions (unless otherwise noted)

| PARAMETER  | MIN                                    | MAX | UNIT |
|--|--|-----|------|
| $t_{w(HP\_SEL)}$ Pulse duration, $\overline{HP\_SEL}$ active | 350                                    |     | ns   |
| $t_{d(VOL)}$ Soft volume update time                         | Defined by rate setting <sup>(1)</sup> |     | ms   |
| $t_{(SW)}$ Switchover time                                   | 0.2                                    | 1   | ms   |

(1) See the *Volume, Treble, and Base Slew Rates Register (0xD0)*, Section 7.26.

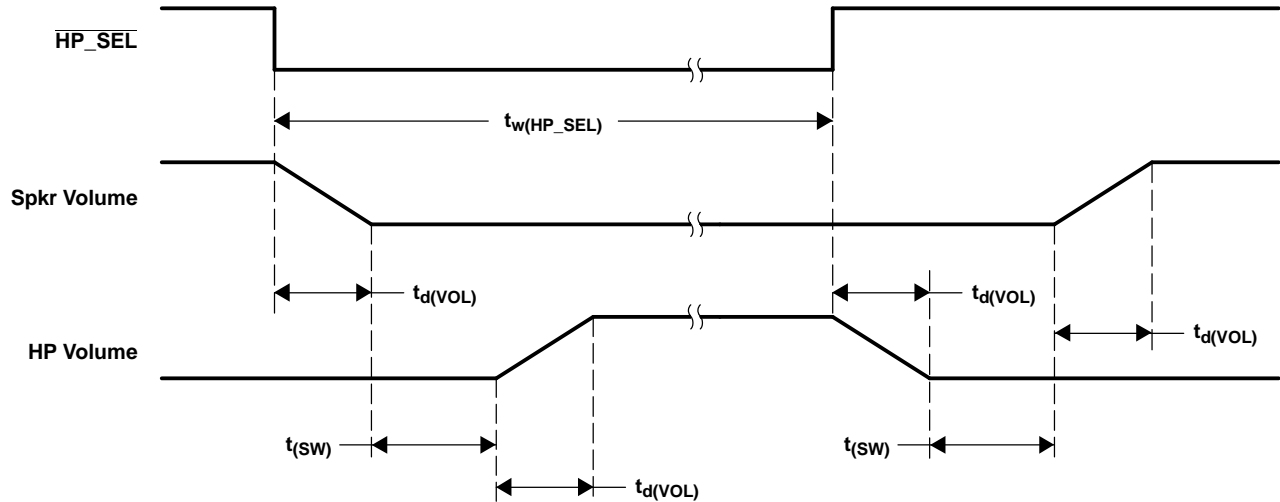

T0033-02

Figure 4-9.  $\overline{HP\_SEL}$  Timing

### 4.7.10 Volume Control

Control signal parameters over recommended operating conditions (unless otherwise noted)

| PARAMETER                                   | TEST CONDITIONS  | MIN                | MAX                  | UNIT  |
|---|--|--------------------|----------------------|-------|
| Maximum attenuation before mute             | Individual volume, master volume, or a combination of both |                    | -109                 | dB    |
| Maximum gain                                | Individual volume, master volume                           |                    | 18                   | dB    |
| Maximum volume before the onset of clipping | 0-dB input, any modulation limit                           |                    | 0                    | dB    |
| PSVC range                                  | PSVC enabled   | 12, 18, or 24      |                      | dB    |
| PSVC rate                                   |  | $f_s$              |                      |       |
| PSVC modulation                             |  | Single sided       |                      |       |
| PSVC quantization                           |  | 2048               |                      | Steps |
| PSVC PWM modulation limits                  | PSVC range = 24 dB   | 6%<br>(120 : 2048) | 95%<br>(1944 : 2048) | dB    |

## 4.8 Serial Audio Interface Control and Timing

### 4.8.1 I<sup>2</sup>S Timing

I<sup>2</sup>S timing uses LRCLK to define when the data being transmitted is for the left channel and when it is for the right channel. LRCLK is low for the left channel and high for the right channel. A bit clock running at  $64 f_s$  is used to clock in the data. From the time the LRCLK signal changes state to the first bit of data on the data lines is a delay of one bit clock. The data is written MSB first and is valid on the rising edge of the bit clock. The TAS5508B masks unused trailing data bit positions.

#### 2-Channel I<sup>2</sup>S (Philips Format) Stereo Input

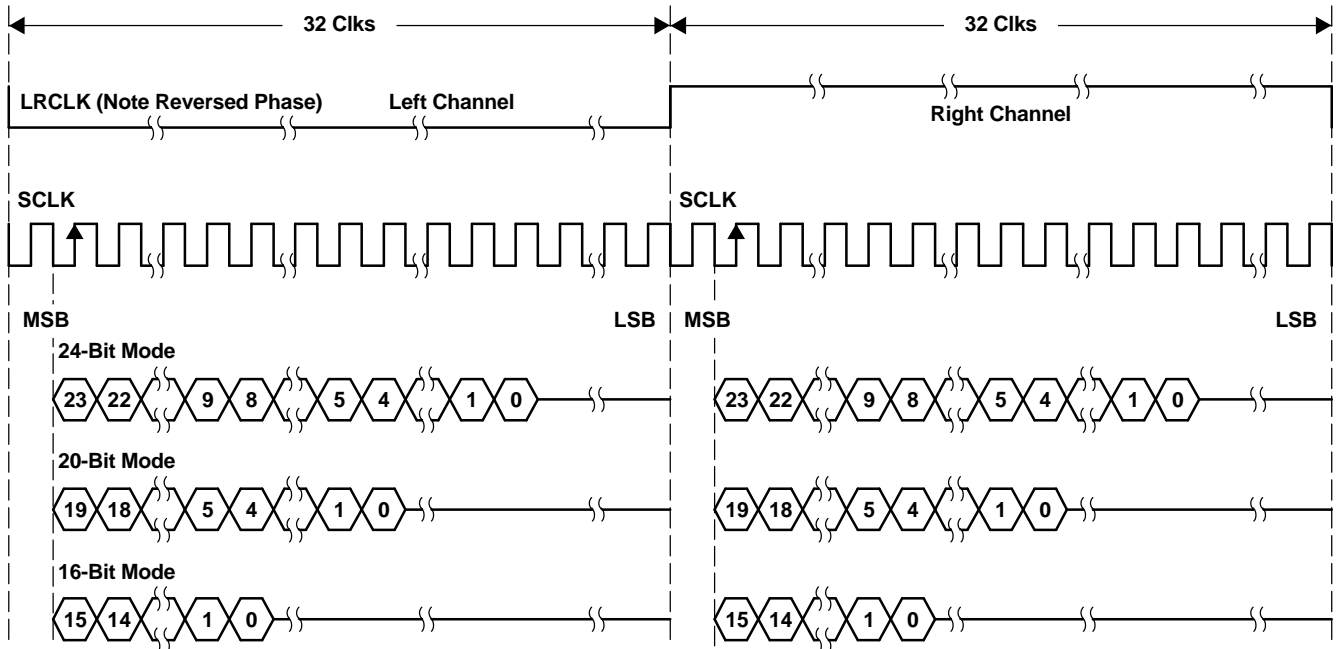

T0034-01

Figure 4-10. I<sup>2</sup>S 64- $f_s$  Format

### 4.8.2 Left-Justified Timing

Left-justified (LJ) timing uses LRCLK to define when the data being transmitted is for the left channel and when it is for the right channel. LRCLK is high for the left channel and low for the right channel. A bit clock running at  $64 f_s$  is used to clock in the data. The first bit of data appears on the data lines at the same time LRCLK toggles. The data is written MSB first and is valid on the rising edge of the bit clock. The TAS5508B masks unused trailing data bit positions.

#### 2-Channel Left-Justified Stereo Input

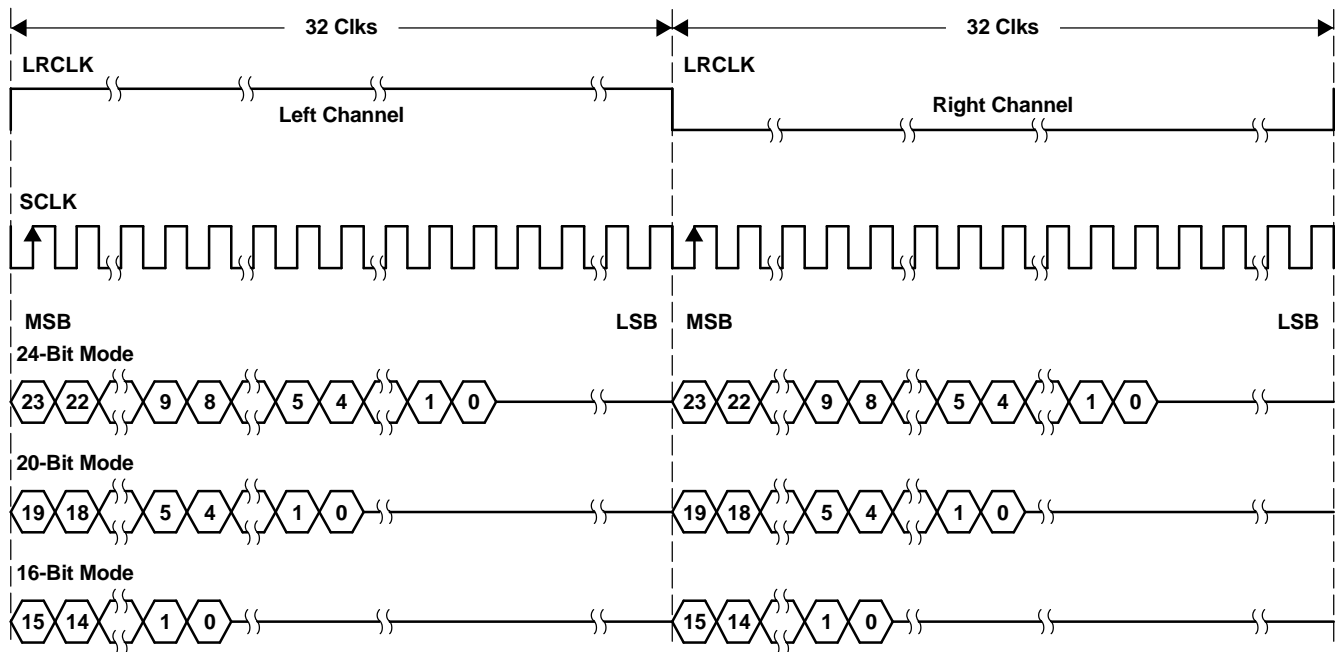

T0034-02

Figure 4-11. Left-Justified  $64 f_s$  Format



### 4.8.3 Right-Justified Timing

Right-justified (RJ) timing uses LRCLK to define when the data being transmitted is for the left channel and when it is for the right channel. LRCLK is high for the left channel and low for the right channel. A bit clock running at  $64 f_s$  is used to clock in the data. The first bit of data appears on the data lines eight bit-clock periods (for 24-bit data) after LRCLK toggles. In RJ mode the LSB of data is always clocked by the last bit clock before LRCLK transitions. The data is written MSB first and is valid on the rising edge of the bit clock. The TAS5508B masks unused leading data bit positions.

#### 2-Channel Right-Justified (Sony Format) Stereo Input

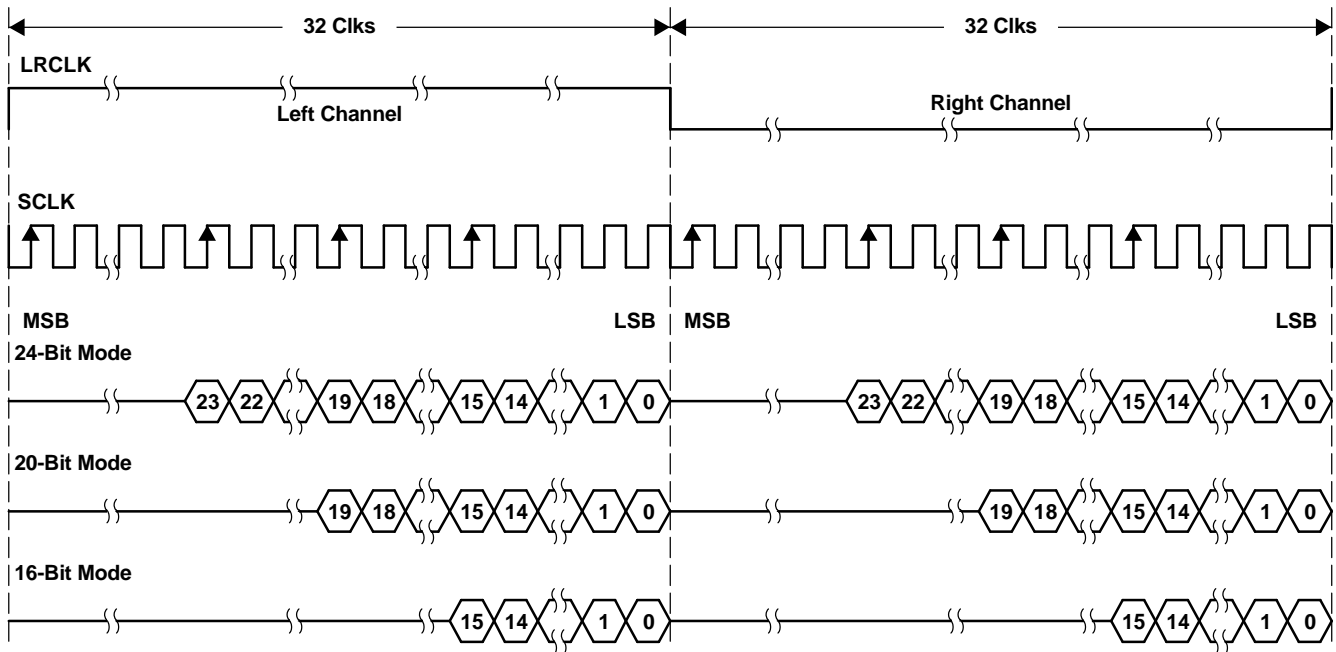

T0034-03

Figure 4-12. Right-Justified  $64\text{-}f_s$  Format

## 5 I<sup>2</sup>C Serial-Control Interface (Slave Addresses 0x36 and 0x37)

The TAS5508B has a bidirectional I<sup>2</sup>C interface that is compatible with the Inter-IC (I<sup>2</sup>C) bus protocol and supports both 100-kbps and 400-kbps data transfer rates for single- and multiple-byte write and read operations. This is a slave-only device that does not support a multimaster bus environment or wait state insertion. The control interface is used to program the registers of the device and to read device status.

The TAS5508B supports the standard-mode I<sup>2</sup>C bus operation (100 kHz maximum) and the fast I<sup>2</sup>C bus operation (400 kHz maximum). The TAS5508B performs all I<sup>2</sup>C operations without I<sup>2</sup>C wait cycles.

The I<sup>2</sup>C write address is 0x36 and the I<sup>2</sup>C read address is 0x37.

### 5.1 General I<sup>2</sup>C Operation

The I<sup>2</sup>C bus employs two signals—SDA (data) and SCL (clock)—to communicate between integrated circuits in a system. Data is transferred on the bus serially, one bit at a time. The address and data can be transferred in byte (8-bit) format, with the most significant bit (MSB) transferred first. In addition, each byte transferred on the bus is acknowledged by the receiving device with an acknowledge bit. Each transfer operation begins with the master device driving a start condition on the bus and ends with the master device driving a stop condition on the bus. The bus uses transitions on SDA while the clock is high to indicate start and stop conditions. A high-to-low transition on SDA indicates a start and a low-to-high transition indicates a stop. Normal data bit transitions must occur within the low time of the clock period. These conditions are shown in Figure 5-1. The master generates the 7-bit slave address and the read/write (R/W) bit to open communication with another device and then waits for an acknowledge condition. The TAS5508B holds SDA low during the acknowledge clock period to indicate an acknowledgement. When this occurs, the master transmits the next byte of the sequence. Each device is addressed by a unique 7-bit slave address plus R/W bit (1 byte). All compatible devices share the same signals via a bidirectional bus using a wired-AND connection. An external pullup resistor must be used for the SDA and SCL signals to set the high level for the bus.

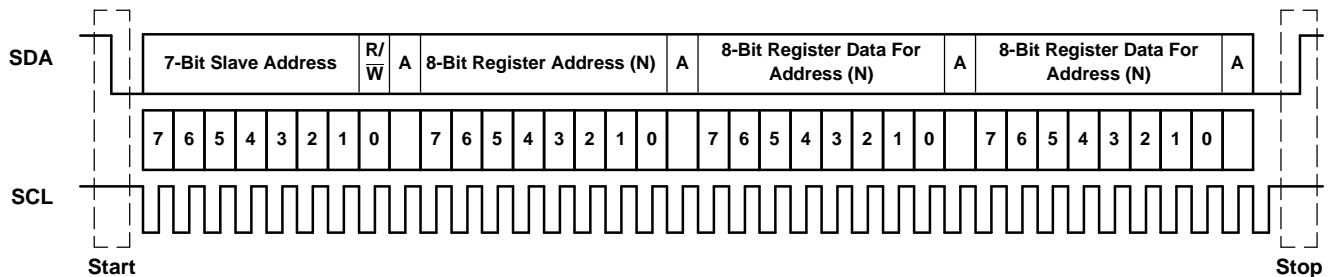

T0035-01

Figure 5-1. Typical I<sup>2</sup>C Sequence

The number of bytes that can be transmitted between start and stop conditions is unlimited. When the last word transfers, the master generates a stop condition to release the bus. A generic data transfer sequence is shown in Figure 5-1.

The 7-bit address for the TAS5508B is 0011011. When the R/W bit is added as the LSB, the I<sup>2</sup>C write address is 0x36 and the I<sup>2</sup>C read address is 0x37.

## 5.2 Single- and Multiple-Byte Transfers

The serial-control interface supports both single-byte and multiple-byte read/write operations for status registers and the general control registers associated with the PWM. However, for the DAP data processing registers, the serial-control interface supports only multiple-byte (four-byte) read/write operations.

During multiple-byte read operations, the TAS5508B responds with data, a byte at a time, starting at the subaddress assigned, as long as the master device continues to respond with acknowledges. If a particular subaddress does not contain 32 bits, the unused bits are read as logic 0.

During multiple-byte write operations, the TAS5508B compares the number of bytes transmitted to the number of bytes that are required for each specific subaddress. If a write command is received for a biquad subaddress, the TAS5508B expects to receive five 32-bit words. If fewer than five 32-bit data words have been received when a stop command (or another start command) is received, the data received is discarded. Similarly, if a write command is received for a mixer coefficient, the TAS5508B expects to receive one 32-bit word.

Supplying a subaddress for each subaddress transaction is referred to as random I<sup>2</sup>C addressing. The TAS5508B also supports sequential I<sup>2</sup>C addressing. For write transactions, if a subaddress is issued followed by data for that subaddress and the 15 subaddresses that follow, a sequential I<sup>2</sup>C write transaction has taken place, and the data for all 16 subaddresses is successfully received by the TAS5508B. For I<sup>2</sup>C sequential write transactions, the subaddress then serves as the start address and the amount of data subsequently transmitted, before a stop or start is transmitted, determines how many subaddresses are written. As is true for random addressing, sequential addressing requires that a complete set of data be transmitted. If only a partial set of data is written to the last subaddress, the data for the last subaddress is discarded. However, all other data written is accepted; only the incomplete data is discarded.

## 5.3 Single-Byte Write

As shown in Figure 5-2, a single-byte, data-write transfer begins with the master device transmitting a start condition followed by the I<sup>2</sup>C device address and the read/write bit. The read/write bit determines the direction of the data transfer. For a write data transfer, the read/write bit is a 0. After receiving the correct I<sup>2</sup>C device address and the read/write bit, the TAS5508B device responds with an acknowledge bit. Next, the master transmits the address byte or bytes corresponding to the TAS5508B internal memory address being accessed. After receiving the address byte, the TAS5508B again responds with an acknowledge bit. Next, the master device transmits the data byte to be written to the memory address being accessed. After receiving the data byte, the TAS5508B again responds with an acknowledge bit. Finally, the master device transmits a stop condition to complete the single-byte, data-write transfer.

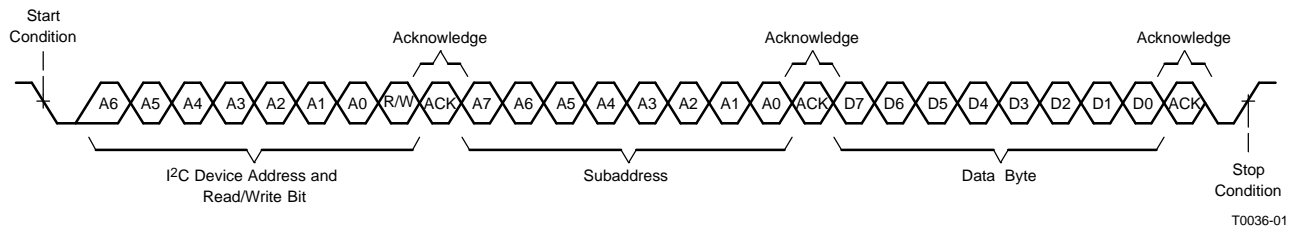

Figure 5-2. Single-Byte Write Transfer

## 5.4 Multiple-Byte Write

A multiple-byte, data-write transfer is identical to a single-byte, data-write transfer except that multiple data bytes are transmitted by the master device to TAS5508B, as shown in Figure 5-3. After receiving each data byte, the TAS5508B responds with an acknowledge bit.

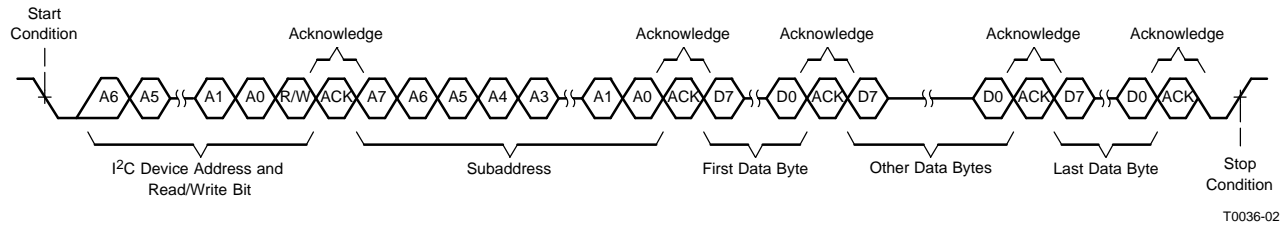

Figure 5-3. Multiple-Byte Write Transfer

## 5.5 Incremental Multiple-Byte Write

The I<sup>2</sup>C supports a special mode which permits I<sup>2</sup>C write operations to be broken up into multiple data write operations that are multiples of four data bytes. These are 6-byte, 10-byte, 14-byte, 18-byte, etc., write operations that are composed of a device address, read/write bit, subaddress, and any multiple of four bytes of data. This permits the system to write large register values incrementally without blocking other I<sup>2</sup>C transactions.

This feature is enabled by the append subaddress function in the TAS5508B. This function enables the TAS5508B to append four bytes of data to a register that was opened by a previous I<sup>2</sup>C register write operation but has not received its complete number of data bytes. Because the length of the long registers is a multiple of four bytes, using four-byte transfers has only an integral number of append operations.

When the correct number of bytes has been received, the TAS5508B starts processing the data.

The procedure to perform an incremental multibyte-write operation is as follows:

1. Start a normal I<sup>2</sup>C write operation by sending the device address, write bit, register subaddress, and the first four bytes of the data to be written. At the end of that sequence, send a stop condition. At this point, the register has been opened and accepts the remaining data that is sent by writing four-byte blocks of data to the append subaddress (0xFE).
2. At a later time, one or more append data transfers are performed to incrementally transfer the remaining number of bytes in sequential order to complete the register write operation. Each of these append operations is composed of the device address, write bit, append subaddress (0xFE), and four bytes of data followed by a stop condition.
3. The operation is terminated due to an error condition, and the data is flushed:
  - a. If a new subaddress is written to the TAS5508B before the correct number of bytes are written.
  - b. If more or fewer than four bytes are data written at the beginning or during any of the append operations.
  - c. If a read bit is sent.

## 5.6 Single-Byte Read

As shown in [Figure 5-4](#), a single-byte, data-read transfer begins with the master device transmitting a start condition followed by the I<sup>2</sup>C device address and the read/write bit. For the data-read transfer, both a write and then a read are actually performed. Initially, a write is performed to transfer the address byte or bytes of the internal memory address to be read. As a result, the read/write bit is a 0. After receiving the TAS5508B address and the read/write bit, the TAS5508B responds with an acknowledge bit. In addition, after sending the internal memory address byte or bytes, the master device transmits another start condition followed by the TAS5508B address and the read/write bit again. This time the read/write bit is a 1, indicating a read transfer. After receiving the TAS5508B address and the read/write bit, the TAS5508B again responds with an acknowledge bit. Next, the TAS5508B transmits the data byte from the memory address being read. After receiving the data byte, the master device transmits a not-acknowledge followed by a stop condition to complete the single-byte, data-read transfer.

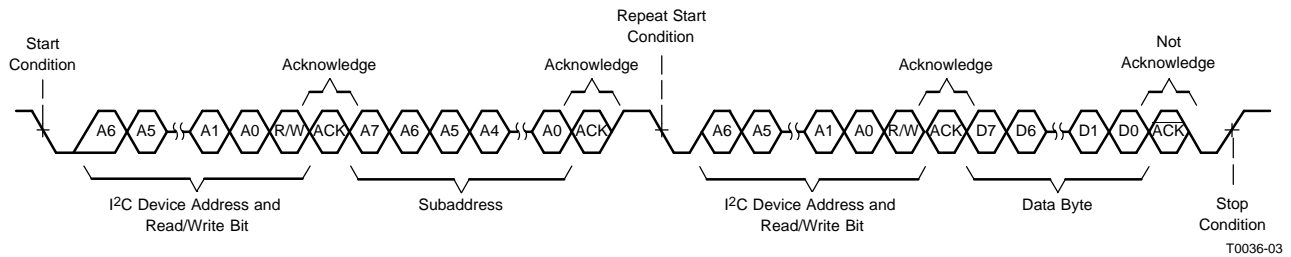

**Figure 5-4. Single-Byte Read Transfer**

## 5.7 Multiple-Byte Read

A multiple-byte, data-read transfer is identical to a single-byte, data-read transfer except that multiple data bytes are transmitted by the TAS5508B to the master device, as shown in [Figure 5-5](#). Except for the last data byte, the master device responds with an acknowledge bit after receiving each data byte.

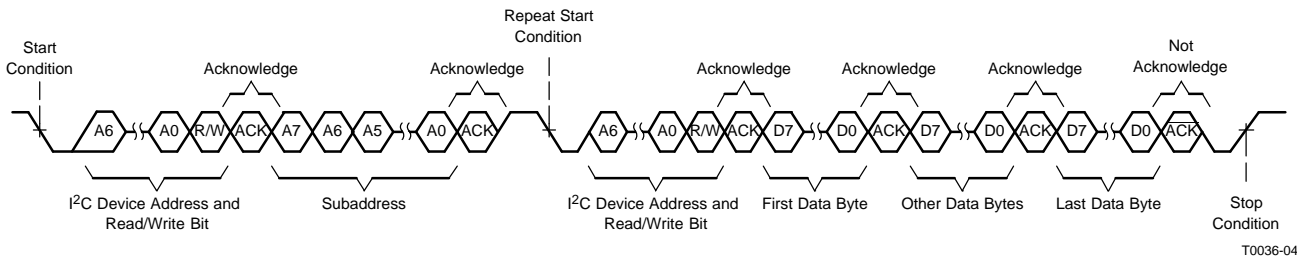

**Figure 5-5. Multiple-Byte Read Transfer**

## 6 Serial-Control I<sup>2</sup>C Register Summary

The TAS5508B slave write address is 0x36 and the read address is 0x37. See *Serial-Control Interface Register Definitions*, [Section 7](#) for complete bit definitions.

Note that u indicates unused bits.

| I <sup>2</sup> C SUBADDRESS | TOTAL BYTES | REGISTER FIELDS   | DESCRIPTION OF CONTENTS  | DEFAULT STATE   |
|-----------------------------|-------------|---|--|---|
| 0x00                        | 1           | Clock control register                                    | Set data rate and MCLK frequency   | 1. $f_S = 48$ kHz<br>2. MCLK = 256 $f_S = 12.288$ MHz   |
| 0x01                        | 1           | General status register                                   | Clip indicator and ID code for the TAS5508B  | 0x03  |
| 0x02                        |             |   | Reserved   |   |
| 0x03                        | 1           | System control register 1                                 | PWM high pass, clock set, unmute select, PSVC select                               | 1. PWM (dc blocking) high-pass filter enabled<br>2. Auto clock set<br>3. Hard unmute on clock error recovery<br>4. PSVC Hi-Z disabled   |
| 0x04                        | 1           | System control register 2                                 | Automute and de-emphasis control   | 1. Automute time-out disabled<br>2. Post-DAP detection automute enabled<br>3. 8-Ch device input detection automute enabled<br>4. Unmute threshold 6 dB over input<br>5. No de-emphasis  |
| 0x05–0x0C                   | 1/reg.      | Channel configuration control registers                   | Configure channels 1, 2, 3, 4, 5, 6, 7, and 8                                      | 1. Enable back-end reset.<br>2. VALID low for reset<br>3. VALID low for mute<br>4. Normal BEPolarity<br>5. Do not remap the output for the TAS5182.<br>6. Do not go low-low in mute.<br>7. Do not remap Hi-Z state to low-low state.  |
| 0x0D                        | 1           | Headphone configuration control register                  | Configure headphone output   | 1. Disable back-end reset sequence.<br>2. VALID does not have to be low for reset.<br>3. VALID does not have to be low for mute.<br>4. Normal BEPolarity<br>5. Do not remap output to comply with TAS5182.<br>6. Do not go low-low in mute.<br>7. Do not remap Hi-Z state to low-low state. |
| 0x0E                        | 1           | Serial data interface control register                    | Set serial data interface to right-justified, I <sup>2</sup> S, or left-justified. | 24-bit I <sup>2</sup> S   |
| 0x0F                        | 1           | Soft mute register  | Soft mute for channels 1, 2, 3, 4, 5, 6, 7, and 8                                  | Unmute all channels.  |
| 0x10–0x13                   |             |   | Reserved   |   |
| 0x14                        | 1           | Automute control register                                 | Set automute delay and threshold.  | 1. Set automute delay = 5 ms.<br>2. Set automute threshold less than bit 8.   |
| 0x15                        | 1           | Automute PWM threshold and back-end reset period register | Set PWM automute threshold; set back-end reset period.                             | 1. Set the PWM threshold the same as the TAS5508B input threshold.<br>2. Set back-end reset period = 5 ms.  |
| 0x16                        | 1           | Modulation index limit register                           | Set modulation index.  | 97.7%   |
| 0x17–0x3F                   |             |   | Reserved   |   |
| 0x40                        | 4           | Bank-switching command register                           | Set up DAP coefficients bank switching for banks 1, 2, and 3                       | Manual selection – bank 1   |
| 0x41–0x48                   | 32/reg.     | Input mixer registers, Ch1–Ch8                            | 8×8 input crossbar mixer setup   | SDIN1 – left to input mixer 1<br>SDIN1 – right to input mixer 2<br>SDIN2 – left to input mixer 3<br>SDIN2 – right to input mixer 4<br>SDIN3 – left to input mixer 5<br>SDIN3 – right to input mixer 6<br>SDIN4 – left to input mixer 7<br>SDIN4 – right to input mixer 8                    |
| 0x49                        | 4           | ipmix_1_to_ch8  | Input mixer 1 to Ch8 mixer coefficient   | 0.0   |
| 0x4A                        | 4           | ipmix_2_to_ch8  | Input mixer 2 to Ch8 mixer coefficient   | 0.0   |
| 0x4B                        | 4           | ipmix_7_to_ch2  | Input mixer 7 to Ch2 mixer coefficient   | 0.0   |
| 0x4C                        | 4           | Ch7_bp_bq2  | Bypass Ch7 biquad 2 coefficient  | 0.0   |
| 0x4D                        | 4           | Ch7_bq2   | Ch7 biquad 2 coefficient   | 1.0   |
| 0x4E                        | 4           | ipmix_8_to_ch12   | Ch8 biquad 2 output to Ch1 mixer and Ch2 mixer coefficient                         | 0.0   |

| PC SUBADDRESS | TOTAL BYTES | REGISTER FIELDS                          | DESCRIPTION OF CONTENTS             | DEFAULT STATE                             |
|---------------|-------------|--|-------------------------------------|---|
| 0x4F          | 4           | Ch8_bp_bq2                               | Bypass Ch8 biquad 2 coefficient     | 0.0                                       |
| 0x50          | 4           | Ch8_bq2                                  | Ch8 biquad 2 coefficient            | 1.0                                       |
| 0x51–0x88     | 20/reg.     | Biquad filter register                   | Ch1–Ch8 biquad filter coefficients  | All biquads = All pass for all channels   |
| 0x89–0x90     | 8           | Bass and treble bypass register, Ch1–Ch8 | Bypass bass and treble for Ch1–Ch8  | Bass and treble bypassed for all channels |
| 0x91          | 4           | Loudness Log2 LG                         | Loudness Log2 LG                    | 0.5                                       |
| 0x92          | 8           | Loudness Log2 LO                         | Loudness Log2 LO                    | 0.0                                       |
| 0x93          | 4           | Loudness G                               | Loudness G                          | 0.0                                       |
| 0x94          | 8           | Loudness O                               | Loudness O                          | 0.0                                       |
| 0x95          | 20          | Loudness biquad                          | Loudness biquad coefficient b0      | 0x00, 0x00, 0xD5, 0x13                    |
|               |             |  | Loudness biquad coefficient b1      | 0x00, 0x00, 0x00, 0x00                    |
|               |             |  | Loudness biquad coefficient b2      | 0x0F, 0xFF, 0x2A, 0xED                    |
|               |             |  | Loudness biquad coefficient a0      | 0x00, 0xFE, 0x50, 0x45                    |
|               |             |  | Loudness biquad coefficient a1      | 0x0F, 0x81, 0xAA, 0x27                    |
| 0x96          | 4           | DRC1 control Ch1–Ch7                     | DRC1 control Ch1–Ch7                | DRC1 disabled in Ch1–Ch7                  |
| 0x97          | 4           | DRC2 control register, Ch8               | DRC2 control Ch8                    | DRC2 disabled in Ch8                      |
| 0x98          | 8           | Ch1–Ch7, DRC1 energy                     | DRC1 energy                         | 0.0041579                                 |
|               |             | Ch1–Ch7, DRC1 (1 – energy)               | DRC1 (1 – energy)                   | 0.9958421                                 |
| 0x99          | 16          | Ch1–Ch7 DRC1 threshold T1                | DRC1 threshold (T1) – upper 2 bytes | 0x00, 0x00, 0x00, 0x00                    |
|               |             |  | DRC1 threshold (T1) – lower 4 bytes | 0x0B, 0x20, 0xE2, 0xB2                    |
|               |             | Ch1–Ch7 DRC1 threshold T2                | DRC1 threshold (T2) – upper 2 bytes | 0x00, 0x00, 0x00, 0x00                    |
|               |             |  | DRC1 threshold (T2) – lower 4 bytes | 0x06, 0xF9, 0xDE, 0x58                    |
| 0x9A          | 12          | Ch1–Ch7, DRC1 slope k0                   | DRC1 slope (k0)                     | 0x0F, 0xC0, 0x00, 0x00                    |
|               |             | Ch1–Ch7, DRC1 slope k1                   | DRC1 slope (k1)                     | 0x0F, 0xC0, 0x00, 0x00                    |
|               |             | Ch1–Ch7 DRC1 slope k2                    | DRC1 slope (k2)                     | 0x0F, 0x90, 0x00, 0x00                    |
| 0x9B          | 16          | Ch1–Ch7 DRC1 offset 1                    | DRC1 offset 1 (O1) – upper 2 bytes  | 0x00, 0x00, 0xFF, 0xFF                    |
|               |             |  | DRC1 offset 1 (O1) – lower 4 bytes  | 0xFF, 0x82, 0x30, 0x98                    |
|               |             | Ch1–Ch7 DRC1 offset 2                    | DRC1 offset 2 (O2) – upper 2 bytes  | 0x00, 0x00, 0x00, 0x00                    |
|               |             |  | DRC1 offset 2 (O2) – lower 4 bytes  | 0x01, 0x95, 0xB2, 0xC0                    |
| 0x9C          | 16          | Ch1–Ch7 DRC1 attack                      | DRC1 attack                         | 0x00, 0x00, 0x88, 0x3F                    |
|               |             | Ch1–Ch7 DRC1 (1 – attack)                | DRC1 (1 – attack)                   | 0x00, 0x7F, 0x77, 0xC0                    |
|               |             | Ch1–Ch7 DRC1 decay                       | DRC1 decay                          | 0x00, 0x00, 0x00, 0xAE                    |
|               |             | Ch1–Ch7 DRC1 (1 – decay)                 | DRC1 (1 – decay)                    | 0x00, 0x7F, 0xFF, 0x51                    |
| 0x9D          | 8           | Ch8 DRC2 energy                          | DRC2 energy                         | 0x00, 0x00, 0x88, 0x3F                    |
|               |             | Ch8 DRC2 (1 – energy)                    | DRC2 (1 – energy)                   | 0x00, 0x7F, 0x77, 0xC0                    |
| 0x9E          | 16          | Ch8 DRC2 threshold T1                    | DRC2 threshold (T1) – upper 2 bytes | 0x00, 0x00, 0x00, 0x00                    |
|               |             |  | DRC2 threshold (T1) – lower 4 bytes | 0x0B, 0x20, 0xE2, 0xB2                    |
|               |             | Ch8 DRC2 threshold T2                    | DRC2 threshold (T2) – upper 2 bytes | 0x00, 0x00, 0x00, 0x00                    |
|               |             |  | DRC2 threshold (T2) – lower 4 bytes | 0x06, 0xF9, 0xDE, 0x58                    |
| 0x9F          | 12          | Ch8 DRC2 slope k0                        | DRC2 slope (k0)                     | 0x00, 0x40, 0x00, 0x00                    |
|               |             | Ch8 DRC2 slope k1                        | DRC2 slope (k1)                     | 0x0F, 0xC0, 0x00, 0x00                    |
|               |             | Ch8 DRC2 slope k2                        | DRC2 slope (k2)                     | 0x0F, 0x90, 0x00, 0x00                    |
| 0xA0          | 16          | Ch8 DRC2 offset 1                        | DRC2 offset (O1) – upper 2 bytes    | 0x00, 0x00, 0xFF, 0xFF                    |
|               |             |  | DRC2 offset (O1) – lower 4 bytes    | 0xFF, 0x82, 0x30, 0x98                    |
|               |             | Ch8 DRC2 offset 2                        | DRC2 offset (O2) – upper 2 bytes    | 0x00, 0x00, 0x00, 0x00                    |
|               |             |  | DRC2 offset (O2) – lower 4 bytes    | 0x01, 0x95, 0xB2, 0xC0                    |
| 0xA1          | 16          | Ch8 DRC2 attack                          | DRC 2 attack                        | 0x00, 0x00, 0x88, 0x3F                    |
|               |             | Ch8 DRC2 (1 – attack)                    | DRC2 (1 – attack)                   | 0x00, 0x7F, 0x77, 0xC0                    |
|               |             | Ch8 DRC2 decay                           | DRC2 decay                          | 0x00, 0x00, 0x00, 0xAE                    |
|               |             | Ch8 DRC2 (1 – decay)                     | DRC2 (1 – decay)                    | 0x00, 0x7F, 0xFF, 0x51                    |

# TAS5508B

## 8-Channel Digital Audio PWM Processor

SLES162B—DECEMBER 2005—REVISED APRIL 2006

| PC SUBADDRESS | TOTAL BYTES | REGISTER FIELDS                              | DESCRIPTION OF CONTENTS                                 | DEFAULT STATE  |
|---------------|-------------|--|---|--|
| 0xA2          | 8           | DRC bypass 1                                 | Ch1 DRC1 bypass coefficient                             | 1.0  |
|               |             | DRC inline 1                                 | Ch1 DRC1 inline coefficient                             | 0.0  |
| 0xA3          | 8           | DRC bypass 2                                 | Ch2 DRC1 bypass coefficient                             | 1.0  |
|               |             | DRC inline 2                                 | Ch2 DRC1 inline coefficient                             | 0.0  |
| 0xA4          | 8           | DRC bypass 3                                 | Ch3 DRC1 bypass coefficient                             | 1.0  |
|               |             | DRC inline 3                                 | Ch3 DRC1 inline coefficient                             | 0.0  |
| 0xA5          | 8           | DRC bypass 4                                 | Ch4 DRC1 bypass coefficient                             | 1.0  |
|               |             | DRC inline 4                                 | Ch4 DRC1 inline coefficient                             | 0.0  |
| 0xA6          | 8           | DRC bypass 5                                 | Ch5 DRC1 bypass coefficient                             | 1.0  |
|               |             | DRC inline 5                                 | Ch5 DRC1 inline coefficient                             | 0.0  |
| 0xA7          | 8           | DRC bypass 6                                 | Ch6 DRC1 bypass coefficient                             | 1.0  |
|               |             | DRC inline 6                                 | Ch6 DRC1 inline coefficient                             | 0.0  |
| 0xA8          | 8           | DRC bypass 7                                 | Ch7 DRC1 bypass coefficient                             | 1.0  |
|               |             | DRC inline 7                                 | Ch7 DRC1 inline coefficient                             | 0.0  |
| 0xA9          | 8           | DRC bypass 8                                 | Ch8 DRC2 bypass coefficient                             | 1.0  |
|               |             | DRC inline 8                                 | Ch8 DRC2 inline coefficient                             | 0.0  |
| 0xAA          | 8           | sel op1–8 and mix to PWM1                    | Select 0 to 2 of eight channels to output mixer 1       | Mix channels to PWM1.  |
| 0xAB          | 8           | sel op1–8 and mix to PWM2                    | Select 0 to 2 of eight channels to output mixer 2       | Mix channels to PWM2.  |
| 0xAC          | 8           | sel op1–8 and mix to PWM3                    | Select 0 to 2 of eight channels to output mixer 3       | Mix channels to PWM3.  |
| 0xAD          | 8           | sel op1–8 and mix to PWM4                    | Select 0 to 2 of eight channels to output mixer 4       | Mix channels to PWM4.  |
| 0xAE          | 8           | sel op1–8 and mix to PWM5                    | Select 0 to 2 of eight channels to output mixer 5       | Mix channels to PWM5.  |
| 0xAF          | 8           | sel op1–8 and mix to PWM6                    | Select 0 to 2 of eight channels to output mixer 6       | Mix channels to PWM6.  |
| 0xB0          | 12          | sel op1–8 and mix to PWM7                    | Select 0 to 3 of eight channels to output mixer 7       | Mix channels to PWM7.  |
| 0xB1          | 12          | sel op1–8 and mix to PWM8                    | Select 0 to 3 of eight channels to output mixer 8       | Mix channels to PWM8.  |
| 0xB2–0xCE     |             |  | Reserved  |  |
| 0xCF          | 20          | Volume biquad                                | Volume biquad   | All pass   |
| 0xD0          | 4           | Volume, treble, and bass slew rates register | u [31:24], u [23:16], u [15:12]<br>VSR[11:8], TBSR[7:0] | 0x00, 0x00, 0x01, 0x3F   |
| 0xD1          | 4           | Ch1 volume                                   | Ch1 volume  | 0 dB   |
| 0xD2          | 4           | Ch2 volume                                   | Ch2 volume  | 0 dB   |
| 0xD3          | 4           | Ch3 volume                                   | Ch3 volume  | 0 dB   |
| 0xD4          | 4           | Ch4 volume                                   | Ch4 volume  | 0 dB   |
| 0xD5          | 4           | Ch5 volume                                   | Ch5 volume  | 0 dB   |
| 0xD6          | 4           | Ch6 volume                                   | Ch6 volume  | 0 dB   |
| 0xD7          | 4           | Ch7 volume                                   | Ch7 volume  | 0 dB   |
| 0xD8          | 4           | Ch8 volume                                   | Ch8 volume  | 0 dB   |
| 0xD9          | 4           | Master volume                                | Master volume   | Mute   |
| 0xDA          | 4           | Bass filter set register                     | Bass filter set (all channels)                          | Filter set 3   |
| 0xDB          | 4           | Bass filter index register                   | Bass filter level (all channels)                        | 0 dB   |
| 0xDC          | 4           | Treble filter set register                   | Treble filter set (all channels)                        | Filter set 3   |
| 0xDD          | 4           | Treble filter index register                 | Treble filter level (all channels)                      | 0 dB   |
| 0xDE          | 4           | AM mode register                             | Set up AM mode for AM-interference reduction            | AM mode disabled<br>Select sequence 1<br>IF frequency = 455 kHz<br>Use BCD-tuned frequency |
| 0xDF          | 4           | PSVC range register                          | Set PSVC control range                                  | 12-dB control range  |
| 0xE0          | 4           | General control register                     | 6- or 8-channel configuration, PSVC enable              | 8-channel configuration<br>Power-supply volume control disabled                            |



| I <sup>2</sup> C<br>SUBADDRESS | TOTAL<br>BYTES | REGISTER FIELDS                     | DESCRIPTION OF CONTENTS | DEFAULT STATE |
|--------------------------------|----------------|-------------------------------------|-------------------------|---------------|
| 0xE1–0xFD                      |                |                                     | Reserved                |               |
| 0xFE                           | 4 (min)        | Multiple-byte write-append register | Special register        | N/A           |
| 0xFF                           |                |                                     | Reserved                |               |

## 7 Serial-Control Interface Register Definitions

Unless otherwise noted, the I<sup>2</sup>C register default values are in **bold** font.

Note that u indicates unused bits.

### 7.1 Clock Control Register (0x00)

Bit D1 is *don't care*.

Table 7-1. Clock Control Register Format

| D7       | D6       | D5       | D4       | D3       | D2       | D1 | D0       | FUNCTION                                       |
|----------|----------|----------|----------|----------|----------|----|----------|--|
| 0        | 0        | 0        | –        | –        | –        |    | –        | 32-kHz data rate                               |
| 0        | 0        | 1        | –        | –        | –        |    | –        | 38-kHz data rate                               |
| 0        | 1        | 0        | –        | –        | –        |    | –        | 44.1-kHz data rate                             |
| <b>0</b> | <b>1</b> | <b>1</b> | –        | –        | –        |    | –        | <b>48-kHz data rate</b>                        |
| 1        | 0        | 0        | –        | –        | –        |    | –        | 88.2-kHz data rate                             |
| 1        | 0        | 1        | –        | –        | –        |    | –        | 96-kHz data rate                               |
| 1        | 1        | 0        | –        | –        | –        |    | –        | 176.4-kHz data rate                            |
| 1        | 1        | 1        | –        | –        | –        |    | –        | 192-kHz data rate                              |
| –        | –        | –        | 0        | 0        | 0        |    |          | MCLK frequency = 64                            |
| –        | –        | –        | 0        | 0        | 1        |    |          | MCLK frequency = 128                           |
| –        | –        | –        | 0        | 1        | 0        |    |          | MCLK frequency = 192                           |
| –        | –        | –        | <b>0</b> | <b>1</b> | <b>1</b> |    |          | <b>MCLK frequency = 256</b>                    |
| –        | –        | –        | 1        | 0        | 0        |    |          | MCLK frequency = 384                           |
| –        | –        | –        | 1        | 0        | 1        |    |          | MCLK frequency = 512                           |
| –        | –        | –        | 1        | 1        | 0        |    |          | MCLK frequency = 768                           |
| –        | –        | –        | 1        | 1        | 1        |    |          | Reserved                                       |
| –        | –        | –        | –        | –        | –        |    | 1        | Clock register is valid (read-only)            |
| –        | –        | –        | –        | –        | –        |    | <b>0</b> | <b>Clock register is not valid (read-only)</b> |

### 7.2 General Status Register 0 (0x01)

Table 7-2. General Status Register Format

| D7 | D6 | D5       | D4       | D3       | D2       | D1       | D0       | FUNCTION                                |
|----|----|----------|----------|----------|----------|----------|----------|---|
| 1  | –  | –        | –        | –        | –        | –        | –        | Clip indicator                          |
| –  | –  | <b>0</b> | <b>0</b> | <b>0</b> | <b>0</b> | <b>1</b> | <b>1</b> | <b>Identification code for TAS5508B</b> |

### 7.3 System Control Register 1 (0x03)

Bits D6, D5, D2, D1, and D0 are *don't care*.

Table 7-3. System Control Register-1 Format

| D7       | D6 | D5 | D4       | D3       | D2 | D1 | D0 | Function  |
|----------|----|----|----------|----------|----|----|----|---|
| 0        |    |    | –        | –        |    |    |    | PWM high pass disabled                          |
| <b>1</b> |    |    | –        | –        |    |    |    | <b>PWM high pass enabled</b>                    |
| –        |    |    | 0        | –        |    |    |    | Soft unmute on recovery from clock error        |
| –        |    |    | <b>1</b> | –        |    |    |    | <b>Hard unmute on recovery from clock error</b> |
| –        |    |    | –        | 1        |    |    |    | PSVC Hi-Z enabled                               |
| –        |    |    | –        | <b>0</b> |    |    |    | <b>PSVC Hi-Z disabled</b>                       |

## 7.4 System Control Register 2 (0x04)

Bits D3 and D2 are *don't care*.

**Table 7-4. System Control Register-2 Format**

| D7 | D6 | D5 | D4 | D3 | D2 | D1 | D0 | Function                                   |
|----|----|----|----|----|----|----|----|--|
| 0  | –  | –  | –  |    |    | –  | –  | Reserved                                   |
| –  | 0  | –  | –  |    |    | –  | –  | Output automute detection enabled          |
| –  | 1  | –  | –  |    |    | –  | –  | Output automute detection disabled         |
| –  | –  | 0  | –  |    |    | –  | –  | Input detection automute enabled           |
| –  | –  | 1  | –  |    |    | –  | –  | Input detection automute disabled          |
| –  | –  | –  | 0  |    |    | –  | –  | Unmute threshold 6 dB over input threshold |
| –  | –  | –  | 1  |    |    | –  | –  | Unmute threshold equal to input threshold  |
| –  | –  | –  | –  |    |    | 0  | 0  | No de-emphasis                             |
| –  | –  | –  | –  |    |    | 0  | 1  | De-emphasis for $f_S = 32$ kHz             |
| –  | –  | –  | –  |    |    | 1  | 0  | De-emphasis for $f_S = 44.1$ kHz           |
| –  | –  | –  | –  |    |    | 1  | 1  | De-emphasis for $f_S = 48$ kHz             |

## 7.5 Channel Configuration Control Registers (0x05–0x0C)

Channels 1, 2, 3, 4, 5, 6, 7, and 8 are mapped into 0x05, 0x06, 0x07, 0x08, 0x09, 0x0A, 0x0B, and 0x0C, respectively. **Note that in 6-channel mode, the channel configuration control registers for lineouts (Ch 5 = 0x09 and Ch 6 = 0x0A) must be 0x00.**

**Table 7-5. Channel Configuration Control Register Format**

| D7 | D6 | D5 | D4 | D3 | D2 | D1 | D0 | FUNCTION  |
|----|----|----|----|----|----|----|----|---|
| 0  | –  | –  | –  | –  | –  | –  |    | Disable back-end reset sequence for a channel.              |
| 1  | –  | –  | –  | –  | –  | –  |    | Enable back-end reset sequence for a channel.               |
| –  | 0  | –  | –  | –  | –  | –  |    | Valid does not have to be low for this channel to be reset. |
| –  | 1  | –  | –  | –  | –  | –  |    | Valid must be low for this channel to be reset.             |
| –  | –  | 0  | –  | –  | –  | –  |    | Valid does not have to be low for this channel to be muted. |
| –  | –  | 1  | –  | –  | –  | –  |    | Valid must be low for this channel to be muted.             |
| –  | –  | –  | 0  | –  | –  | –  |    | Normal BEPolarity   |
| –  | –  | –  | 1  | –  | –  | –  |    | Switches PWM+ and PWM– and inverts audio signal             |
| –  | –  | –  | –  | 0  | –  | –  |    | Do not remap output to comply with 5182 interface.          |
| –  | –  | –  | –  | 1  | –  | –  |    | Remap output to comply with 5182 interface.                 |
| –  | –  | –  | –  | –  | 0  | –  |    | Do not go to low-low in mute.                               |
| –  | –  | –  | –  | –  | 1  | –  |    | Go to low-low in mute.                                      |
| –  | –  | –  | –  | –  | –  | 0  |    | Do not remap Hi-Z state to low-low state.                   |
| –  | –  | –  | –  | –  | –  | 1  |    | Remap Hi-Z state to low-low state.                          |

## 7.6 Headphone Configuration Control Register (0x0D)

Bit D0 is *don't care*.

**Table 7-6. Headphone Configuration Control Register Format**

| D7 | D6 | D5 | D4 | D3 | D2 | D1 | D0 | FUNCTION   |
|----|----|----|----|----|----|----|----|--|
| 0  | –  | –  | –  | –  | –  | –  |    | Disable back-end reset sequence for a channel.                     |
| 1  | –  | –  | –  | –  | –  | –  |    | Enable back-end reset sequence for a channel.                      |
| –  | 0  | –  | –  | –  | –  | –  |    | <b>Valid does not have to be low for this channel to be reset.</b> |
| –  | 1  | –  | –  | –  | –  | –  |    | Valid must be low for this channel to be reset.                    |
| –  | –  | 0  | –  | –  | –  | –  |    | <b>Valid does not have to be low for this channel to be muted.</b> |
| –  | –  | 1  | –  | –  | –  | –  |    | Valid must be low for this channel to be muted.                    |
| –  | –  | –  | 0  | –  | –  | –  |    | <b>Normal BEPolarity</b>   |
| –  | –  | –  | 1  | –  | –  | –  |    | Switches PWM+ and PWM– and inverts audio signal                    |
| –  | –  | –  | –  | 0  | –  | –  |    | <b>Do not remap output to comply with 5182 interface.</b>          |
| –  | –  | –  | –  | 1  | –  | –  |    | Remap output to comply with 5182 interface.                        |
| –  | –  | –  | –  | –  | 0  | –  |    | <b>Do not go to low-low in mute.</b>                               |
| –  | –  | –  | –  | –  | 1  | –  |    | Go to low-low in mute.   |
| –  | –  | –  | –  | –  | –  | 0  |    | <b>Do not remap Hi-Z state to low-low state.</b>                   |
| –  | –  | –  | –  | –  | –  | 1  |    | Remap Hi-Z state to low-low state.                                 |

## 7.7 Serial Data Interface Control Register (0x0E)

Nine serial modes can be programmed via the I<sup>2</sup>C interface.

**Table 7-7. Serial Data Interface Control Register Format**

| RECEIVE SERIAL DATA<br>INTERFACE FORMAT | WORD LENGTHS | D7–D4 | D3       | D2       | D1       | D0       |
|---|--------------|-------|----------|----------|----------|----------|
| Right-justified                         | 16           | 0000  | 0        | 0        | 0        | 0        |
| Right-justified                         | 20           | 0000  | 0        | 0        | 0        | 1        |
| Right-justified                         | 24           | 0000  | 0        | 0        | 1        | 0        |
| I <sup>2</sup> S                        | 16           | 0000  | 0        | 0        | 1        | 1        |
| I <sup>2</sup> S                        | 20           | 0000  | 0        | 1        | 0        | 0        |
| <b>I<sup>2</sup>S</b>                   | <b>24</b>    | 0000  | <b>0</b> | <b>1</b> | <b>0</b> | <b>1</b> |
| Left-justified                          | 16           | 0000  | 0        | 1        | 1        | 0        |
| Left-justified                          | 20           | 0000  | 0        | 1        | 1        | 1        |
| Left-justified                          | 24           | 0000  | 1        | 0        | 0        | 0        |
| Reserved                                |              | 0000  | 1        | 0        | 0        | 1        |
| Reserved                                |              | 0000  | 1        | 0        | 1        | 0        |
| Reserved                                |              | 0000  | 1        | 0        | 1        | 1        |
| Reserved                                |              | 0000  | 1        | 1        | 0        | 0        |
| Reserved                                |              | 0000  | 1        | 1        | 0        | 1        |
| Reserved                                |              | 0000  | 1        | 1        | 1        | 0        |
| Reserved                                |              | 0000  | 1        | 1        | 1        | 1        |

## 7.8 Soft Mute Register (0x0F)

Do not use this register if using the remapped output mixer configuration.

**Table 7-8. Soft Mute Register Format**

| D7       | D6       | D5       | D4       | D3       | D2       | D1       | D0       | FUNCTION                   |
|----------|----------|----------|----------|----------|----------|----------|----------|----------------------------|
| –        | –        | –        | –        | –        | –        | –        | 1        | Soft mute channel 1        |
| –        | –        | –        | –        | –        | –        | 1        | –        | Soft mute channel 2        |
| –        | –        | –        | –        | –        | 1        | –        | –        | Soft mute channel 3        |
| –        | –        | –        | –        | 1        | –        | –        | –        | Soft mute channel 4        |
| –        | –        | –        | 1        | –        | –        | –        | –        | Soft mute channel 5        |
| –        | –        | 1        | –        | –        | –        | –        | –        | Soft mute channel 6        |
| –        | 1        | –        | –        | –        | –        | –        | –        | Soft mute channel 7        |
| 1        | –        | –        | –        | –        | –        | –        | –        | Soft mute channel 8        |
| <b>0</b> | <b>0</b> | <b>0</b> | <b>0</b> | <b>0</b> | <b>0</b> | <b>0</b> | <b>0</b> | <b>Unmute all channels</b> |

## 7.9 Automute Control Register (0x14)

For more information on how to use this register, see *Automute and Mute Channel Controls*, [Section 2.8](#).

**Table 7-9. Automute Control Register Format**

| D7       | D6       | D5       | D4       | D3       | D2       | D1       | D0       | FUNCTION   |
|----------|----------|----------|----------|----------|----------|----------|----------|--|
| –        | –        | –        | –        | 0        | 0        | 0        | 0        | Set input automute and output automute delay to 1 ms   |
| –        | –        | –        | –        | 0        | 0        | 0        | 1        | Set input automute and output automute delay to 2 ms   |
| –        | –        | –        | –        | 0        | 0        | 1        | 0        | Set input automute and output automute delay to 3 ms   |
| –        | –        | –        | –        | 0        | 0        | 1        | 1        | Set input automute and output automute delay to 4 ms   |
| –        | –        | –        | –        | <b>0</b> | <b>1</b> | <b>0</b> | <b>0</b> | <b>Set input automute and output automute delay to 5 ms</b>                                  |
| –        | –        | –        | –        | 0        | 1        | 0        | 1        | Set input automute and output automute delay to 10 ms  |
| –        | –        | –        | –        | 0        | 1        | 1        | 0        | Set input automute and output automute delay to 20 ms  |
| –        | –        | –        | –        | 0        | 1        | 1        | 1        | Set input automute and output automute delay to 30 ms  |
| –        | –        | –        | –        | 1        | 0        | 0        | 0        | Set input automute and output automute delay to 40 ms  |
| –        | –        | –        | –        | 1        | 0        | 0        | 1        | Set input automute and output automute delay to 50 ms  |
| –        | –        | –        | –        | 1        | 0        | 1        | 0        | Set input automute and output automute delay to 60 ms  |
| –        | –        | –        | –        | 1        | 0        | 1        | 1        | Set input automute and output automute delay to 70ms   |
| –        | –        | –        | –        | 1        | 1        | 0        | 0        | Set input automute and output automute delay to 80 ms  |
| –        | –        | –        | –        | 1        | 1        | 0        | 1        | Set input automute and output automute delay to 90 ms  |
| –        | –        | –        | –        | 1        | 1        | 1        | 0        | Set input automute and output automute delay to 100 ms                                       |
| –        | –        | –        | –        | 1        | 1        | 1        | 1        | Set input automute and output automute delay to 110 ms                                       |
| 0        | 0        | 0        | 0        | –        | –        | –        | –        | Set input automute threshold less than bit 1 (zero input signal), lowest automute threshold. |
| 0        | 0        | 0        | 1        | –        | –        | –        | –        |  |
| 0        | 0        | 1        | 0        | –        | –        | –        | –        | Set input automute threshold less than bit 2   |
| 0        | 0        | 1        | 1        | –        | –        | –        | –        | Set input automute threshold less than bit 3   |
| 0        | 1        | 0        | 0        | –        | –        | –        | –        | Set input automute threshold less than bit 4   |
| 0        | 1        | 0        | 1        | –        | –        | –        | –        | Set input automute threshold less than bit 5   |
| 0        | 1        | 1        | 0        | –        | –        | –        | –        | Set input automute threshold less than bit 6   |
| 0        | 1        | 1        | 1        | –        | –        | –        | –        | Set input automute threshold less than bit 7   |
| <b>1</b> | <b>0</b> | <b>0</b> | <b>0</b> | –        | –        | –        | –        | <b>Set input automute threshold less than bit 8</b>  |
| 1        | 0        | 0        | 1        | –        | –        | –        | –        | Set input automute threshold less than bit 9   |
| 1        | 0        | 1        | 0        | –        | –        | –        | –        | Set input automute threshold less than bit 10  |
| 1        | 0        | 1        | 1        | –        | –        | –        | –        | Set input automute threshold less than bit 11  |
| 1        | 1        | 0        | 0        | –        | –        | –        | –        | Set input automute threshold less than bit 12  |
| 1        | 1        | 0        | 1        | –        | –        | –        | –        | Set input automute threshold less than bit 13  |
| 1        | 1        | 1        | 0        | –        | –        | –        | –        | Set input automute threshold less than bit 14  |
| 1        | 1        | 1        | 1        | –        | –        | –        | –        | Set input automute threshold less than bit 15  |

## 7.10 Output Automute PWM Threshold and Back-End Reset Period Register (0x15)

For more information on how to use this register, see *Automute and Mute Channel Controls*, [Section 2.8](#).

**Table 7-10. Automute PWM Threshold and Back-End Reset Period Register Format**

| D7 | D6 | D5 | D4 | D3 | D2 | D1 | D0 | FUNCTION  |
|----|----|----|----|----|----|----|----|---|
| 0  | 0  | 0  | 0  | –  | –  | –  | –  | <b>Set output automute threshold equal to input automute threshold</b>  |
| 0  | 0  | 0  | 1  | –  | –  | –  | –  | Set output automute threshold 1 bit more than input automute threshold  |
| 0  | 0  | 1  | 0  | –  | –  | –  | –  | Set output automute threshold 2 bits more than input automute threshold |
| 0  | 0  | 1  | 1  | –  | –  | –  | –  | Set output automute threshold 3 bits more than input automute threshold |
| 0  | 1  | 0  | 0  | –  | –  | –  | –  | Set output automute threshold 4 bits more than input automute threshold |
| 0  | 1  | 0  | 1  | –  | –  | –  | –  | Set output automute threshold 5 bits more than input automute threshold |
| 0  | 1  | 1  | 0  | –  | –  | –  | –  | Set output automute threshold 6 bits more than input automute threshold |
| 0  | 1  | 1  | 1  | –  | –  | –  | –  | Set output automute threshold 7 bits more than input automute threshold |
| 1  | 0  | 0  | 0  | –  | –  | –  | –  | Set output automute threshold equal to input automute threshold         |
| 1  | 0  | 0  | 1  | –  | –  | –  | –  | Set output automute threshold 1 bit less than input automute threshold  |
| 1  | 0  | 1  | 0  | –  | –  | –  | –  | Set output automute threshold 2 bits less than input automute threshold |
| 1  | 0  | 1  | 1  | –  | –  | –  | –  | Set output automute threshold 3 bits less than input automute threshold |
| 1  | 1  | 0  | 0  | –  | –  | –  | –  | Set output automute threshold 4 bits less than input automute threshold |
| 1  | 1  | 0  | 1  | –  | –  | –  | –  | Set output automute threshold 5 bits less than input automute threshold |
| 1  | 1  | 1  | 0  | –  | –  | –  | –  | Set output automute threshold 6 bits less than input automute threshold |
| 1  | 1  | 1  | 1  | –  | –  | –  | –  | Set output automute threshold 7 bits less than input automute threshold |
| –  | –  | –  | –  | 0  | 0  | 0  | 0  | Set back-end reset period < 1 ms  |
| –  | –  | –  | –  | 0  | 0  | 0  | 1  | Set back-end reset period 1 ms  |
| –  | –  | –  | –  | 0  | 0  | 1  | 0  | Set back-end reset period 2 ms  |
| –  | –  | –  | –  | 0  | 0  | 1  | 1  | Set back-end reset period 3 ms  |
| –  | –  | –  | –  | 0  | 1  | 0  | 0  | Set back-end reset period 4 ms  |
| –  | –  | –  | –  | 0  | 1  | 0  | 1  | <b>Set back-end reset period 5 ms</b>                                   |
| –  | –  | –  | –  | 0  | 1  | 1  | 0  | Set back-end reset period 6 ms  |
| –  | –  | –  | –  | 0  | 1  | 1  | 1  | Set back-end reset period 7 ms  |
| –  | –  | –  | –  | 1  | 0  | 0  | 0  | Set back-end reset period 8 ms  |
| –  | –  | –  | –  | 1  | 0  | 0  | 1  | Set back-end reset period 9 ms  |
| –  | –  | –  | –  | 1  | 0  | 1  | 0  | Set back-end reset period 10 ms   |
| –  | –  | –  | –  | 1  | 0  | 1  | 1  | Set back-end reset period 10 ms   |
| –  | –  | –  | –  | 1  | 1  | X  | X  | Set back-end reset period 10 ms   |

### 7.11 Modulation Index Limit Register (0x16)

Bits D7–D3 are *don't care*. Note that some power stages require a lower modulation limit than the default of 97.7%. Contact Texas Instruments for more details about the requirements for a particular power stage.

**Table 7-11. Modulation Index Limit Register Format**

| D7 | D6 | D5 | D4 | D3 | D2       | D1       | D0       | LIMIT<br>[DCLKs] | MIN WIDTH<br>[DCLKs] | MODULATION<br>INDEX |
|----|----|----|----|----|----------|----------|----------|------------------|----------------------|---------------------|
|    |    |    |    |    | 0        | 0        | 0        | 1                | 2                    | 99.2%               |
|    |    |    |    |    | 0        | 0        | 1        | 2                | 4                    | 98.4%               |
|    |    |    |    |    | <b>0</b> | <b>1</b> | <b>0</b> | <b>3</b>         | <b>6</b>             | <b>97.7%</b>        |
|    |    |    |    |    | 0        | 1        | 1        | 4                | 8                    | 96.9%               |
|    |    |    |    |    | 1        | 0        | 0        | 5                | 10                   | 96.1%               |
|    |    |    |    |    | 1        | 0        | 1        | 6                | 12                   | 95.3%               |
|    |    |    |    |    | 1        | 1        | 0        | 7                | 14                   | 94.5%               |
|    |    |    |    |    | 1        | 1        | 1        | 8                | 16                   | 93.8%               |



## 7.12 Bank-Switching Command Register (0x40)

Bits D31–D24, D22–D19 are *don't care*.

**Table 7-12. Bank-Switching Command Register Format**

| D31 | D30 | D29 | D28 | D27 | D26 | D25 | D24 | FUNCTION  |
|-----|-----|-----|-----|-----|-----|-----|-----|---|
|     |     |     |     |     |     |     |     | Unused bits                                       |
| D23 | D22 | D21 | D20 | D19 | D18 | D17 | D16 | FUNCTION  |
| –   |     |     |     |     | 0   | 0   | 0   | Manual selection bank 1                           |
| –   |     |     |     |     | 0   | 0   | 1   | Manual selection bank 2                           |
| –   |     |     |     |     | 0   | 1   | 0   | Manual selection bank 3                           |
| –   |     |     |     |     | 0   | 1   | 1   | Automatic bank selection                          |
| –   |     |     |     |     | 1   | 0   | 0   | Update the values in bank 1                       |
| –   |     |     |     |     | 1   | 0   | 1   | Update the values in bank 2                       |
| –   |     |     |     |     | 1   | 1   | 0   | Update the values in bank 3                       |
| –   |     |     |     |     | 1   | 1   | 1   | Update only the bank map                          |
| 0   |     |     |     |     | –   | –   | –   | Update the bank map using values in D15–D0        |
| 1   |     |     |     |     | –   | –   | –   | Do not update the bank map using values in D15–D0 |
| D15 | D14 | D13 | D12 | D11 | D10 | D9  | D8  | FUNCTION  |
| 1   | –   | –   | –   | –   | –   | –   | –   | 32-kHz data rate—use bank 1                       |
| –   | 1   | –   | –   | –   | –   | –   | –   | 38-kHz data rate—use bank 1                       |
| –   | –   | 1   | –   | –   | –   | –   | –   | 44.1-kHz data rate—use bank 1                     |
| –   | –   | –   | 1   | –   | –   | –   | –   | 48-kHz data rate—use bank 1                       |
| –   | –   | –   | –   | 1   | –   | –   | –   | 88.2-kHz data rate—use bank 1                     |
| –   | –   | –   | –   | –   | 1   | –   | –   | 96-kHz data rate—use bank 1                       |
| –   | –   | –   | –   | –   | –   | 1   | –   | 176.4-kHz data rate—use bank 1                    |
| –   | –   | –   | –   | –   | –   | –   | 1   | 192-kHz data rate—use bank 1                      |
| 1   | 1   | 1   | 1   | 1   | 1   | 1   | 1   | Default   |
| D7  | D6  | D5  | D4  | D3  | D2  | D1  | D0  | FUNCTION  |
| 1   | –   | –   | –   | –   | –   | –   | –   | 32-kHz data rate—use bank 2                       |
| –   | 1   | –   | –   | –   | –   | –   | –   | 38-kHz data rate—use bank 2                       |
| –   | –   | 1   | –   | –   | –   | –   | –   | 44.1-kHz data rate—use bank 2                     |
| –   | –   | –   | 1   | –   | –   | –   | –   | 48-kHz data rate—use bank 2                       |
| –   | –   | –   | –   | 1   | –   | –   | –   | 88.2-kHz data rate—use bank 2                     |
| –   | –   | –   | –   | –   | 1   | –   | –   | 96-kHz data rate—use bank 2                       |
| –   | –   | –   | –   | –   | –   | 1   | –   | 176.4-kHz data rate—use bank 2                    |
| –   | –   | –   | –   | –   | –   | –   | 1   | 192-kHz data rate—use bank 2                      |
| 0   | 0   | 0   | 0   | 0   | 0   | 0   | 0   | Default   |

### 7.13 Input Mixer Registers, Channels 1–8 (0x41–0x48)

Input mixers 1, 2, 3, 4, 5, 6, 7, and 8 are mapped into registers 0x41, 0x42, 0x43, 0x44, 0x45, 0x46, 0x47, and 0x48, respectively.

Each gain coefficient is in 28-bit (5.23) format, so 0x80 0000 is a gain of 1. Each gain coefficient is written as a 32-bit word with the upper four bits not used. For eight gain coefficients, the total is 32 bytes.

**Bold** indicates the one channel that is passed through the mixer.

**Table 7-13. Channel 1–8 Input Mixer Register Format**

| I <sup>2</sup> C SUBADDRESS | TOTAL BYTES | REGISTER FIELDS      | DESCRIPTION OF CONTENTS  | DEFAULT STATE                 |
|-----------------------------|-------------|----------------------|--|-------------------------------|
| 0x41                        | 32          | A_to_ipmix[1]        | <b>SDIN1-left (Ch1) A to input mixer 1 coefficient (default = 1)</b><br>u[31:28], A_1[27:24], A_1[23:16], A_1[15:8], A_1[7:0]  | <b>0x00, 0x80, 0x00, 0x00</b> |
|                             |             | B_to_ipmix[1]        | SDIN1-right (Ch2) B to input mixer 1 coefficient (default = 0)<br>u[31:28], B_1[27:24], B_1[23:16], B_1[15:8], B_1[7:0]        | 0x00, 0x00, 0x00, 0x00        |
|                             |             | C_to_ipmix[1]        | SDIN2-left (Ch3) C to input mixer 1 coefficient (default = 0)<br>u[31:28], C_1[27:24], C_1[23:16], C_1[15:8], C_1[7:0]         | 0x00, 0x00, 0x00, 0x00        |
|                             |             | D_to_ipmix[1]        | SDIN2-right (Ch4) D to input mixer 1 coefficient (default = 0)<br>u[31:28], D_1[27:24], D_1[23:16], D_1[15:8], D_1[7:0]        | 0x00, 0x00, 0x00, 0x00        |
|                             |             | E_to_ipmix[1]        | SDIN3-left (Ch5) E to input mixer 1 coefficient (default = 0)<br>u[31:28], E_1[27:24], E_1[23:16], E_1[15:8], E_1[7:0]         | 0x00, 0x00, 0x00, 0x00        |
|                             |             | F_to_ipmix[1]        | SDIN3-right (Ch6) F to input mixer 1 coefficient (default = 0)<br>u[31:28], F_1[27:24], F_1[23:16], F_1[15:8], F_1[7:0]        | 0x00, 0x00, 0x00, 0x00        |
|                             |             | G_to_ipmix[1]        | SDIN4-left (Ch7) G to input mixer 1 coefficient (default = 0)<br>u[31:28], G_1[27:24], G_1[23:16], G_1[15:8], G_1[7:0]         | 0x00, 0x00, 0x00, 0x00        |
|                             |             | H_to_ipmix[1]        | SDIN4-right (Ch8) H to input mixer 1 coefficient (default = 0)<br>u[31:28], H_1[27:24], H_1[23:16], H_1[15:8], H_1[7:0]        | 0x00, 0x00, 0x00, 0x00        |
| 0x42                        | 32          | A_to_ipmix[2]        | SDIN1-left (Ch1) A to input mixer 2 coefficient (default = 0)<br>u[31:28], A_2[27:24], A_2[23:16], A_2[15:8], A_2[7:0]         | 0x00, 0x00, 0x00, 0x00        |
|                             |             | <b>B_to_ipmix[2]</b> | <b>SDIN1-right (Ch2) B to input mixer 2 coefficient (default = 1)</b><br>u[31:28], B_2[27:24], B_2[23:16], B_2[15:8], B_2[7:0] | <b>0x00, 0x80, 0x00, 0x00</b> |
|                             |             | C_to_ipmix[2]        | SDIN2-left (Ch3) C to input mixer 2 coefficient (default = 0)<br>u[31:28], C_2[27:24], C_2[23:16], C_2[15:8], C_2[7:0]         | 0x00, 0x00, 0x00, 0x00        |
|                             |             | D_to_ipmix[2]        | SDIN2-right (Ch4) D to input mixer 2 coefficient (default = 0)<br>u[31:28], D_2[27:24], D_2[23:16], D_2[15:8], D_2[7:0]        | 0x00, 0x00, 0x00, 0x00        |
|                             |             | E_to_ipmix[2]        | SDIN3-left (Ch5) E to input mixer 2 coefficient (default = 0)<br>u[31:28], E_2[27:24], E_2[23:16], E_2[15:8], E_2[7:0]         | 0x00, 0x00, 0x00, 0x00        |
|                             |             | F_to_ipmix[2]        | SDIN3-right (Ch6) F to input mixer 2 coefficient (default = 0)<br>u[31:28], F_2[27:24], F_2[23:16], F_2[15:8], F_2[7:0]        | 0x00, 0x00, 0x00, 0x00        |
|                             |             | G_to_ipmix[2]        | SDIN4-left (Ch7) G to input mixer 2 coefficient (default = 0)<br>u[31:28], G_2[27:24], G_2[23:16], G_2[15:8], G_2[7:0]         | 0x00, 0x00, 0x00, 0x00        |
|                             |             | H_to_ipmix[2]        | SDIN4-right (Ch8) H to input mixer 2 coefficient (default = 0)<br>u[31:28], H_2[27:24], H_2[23:16], H_2[15:8], H_2[7:0]        | 0x00, 0x00, 0x00, 0x00        |

**Table 7-13. Channel 1–8 Input Mixer Register Format (continued)**

| PC SUBADDRESS | TOTAL BYTES | REGISTER FIELDS      | DESCRIPTION OF CONTENTS   | DEFAULT STATE                 |
|---------------|-------------|----------------------|---|-------------------------------|
| 0x43          | 32          | A_to_ipmix[3]        | SDIN1-left (Ch1) A to input mixer 3 coefficient (default = 0)<br>u[31:28], A_3[27:24], A_3[23:16], A_3[15:8], A_3[7:0]          | 0x00, 0x00, 0x00, 0x00        |
|               |             | B_to_ipmix[3]        | SDIN1-right (Ch2) B to input mixer 3 coefficient (default = 0)<br>u[31:28], B_3[27:24], B_3[23:16], B_3[15:8], B_3[7:0]         | 0x00, 0x00, 0x00, 0x00        |
|               |             | <b>C_to_ipmix[3]</b> | <b>SDIN2-left (Ch3) C to input mixer 3 coefficient (default = 1)<br/>u[31:28], C_3[27:24], C_3[23:16], C_3[15:8], C_3[7:0]</b>  | <b>0x00, 0x80, 0x00, 0x00</b> |
|               |             | D_to_ipmix[3]        | SDIN2-right (Ch4) D to input mixer 3 coefficient (default = 0)<br>u[31:28], D_3[27:24], D_3[23:16], D_3[15:8], D_3[7:0]         | 0x00, 0x00, 0x00, 0x00        |
|               |             | E_to_ipmix[3]        | SDIN3-left (Ch5) E to input mixer 3 coefficient (default = 0)<br>u[31:28], E_3[27:24], E_3[23:16], E_3[15:8], E_3[7:0]          | 0x00, 0x00, 0x00, 0x00        |
|               |             | F_to_ipmix[3]        | SDIN3-right (Ch6) F to input mixer 3 coefficient (default = 0)<br>u[31:28], F_3[27:24], F_3[23:16], F_3[15:8], F_3[7:0]         | 0x00, 0x00, 0x00, 0x00        |
|               |             | G_to_ipmix[3]        | SDIN4-left (Ch7) G to input mixer 3 coefficient (default = 0)<br>u[31:28], G_3[27:24], G_3[23:16], G_3[15:8], G_3[7:0]          | 0x00, 0x00, 0x00, 0x00        |
|               |             | H_to_ipmix[3]        | SDIN4-right (Ch8) H to input mixer 3 coefficient (default = 0)<br>u[31:28], H_3[27:24], H_3[23:16], H_3[15:8], H_3[7:0]         | 0x00, 0x00, 0x00, 0x00        |
| 0x44          | 32          | A_to_ipmix[4]        | SDIN1-left (Ch1) A to input mixer 4 coefficient (default = 0)<br>u[31:28], A_4[27:24], A_4[23:16], A_4[15:8], A_4[7:0]          | 0x00, 0x00, 0x00, 0x00        |
|               |             | B_to_ipmix[4]        | SDIN1-right (Ch2) B to input mixer 4 coefficient (default = 0)<br>u[31:28], B_4[27:24], B_4[23:16], B_4[15:8], B_4[7:0]         | 0x00, 0x00, 0x00, 0x00        |
|               |             | C_to_ipmix[4]        | SDIN2-left (Ch3) C to input mixer 4 coefficient (default = 0)<br>u[31:28], C_4[27:24], C_4[23:16], C_4[15:8], C_4[7:0]          | 0x00, 0x00, 0x00, 0x00        |
|               |             | <b>D_to_ipmix[4]</b> | <b>SDIN2-right (Ch4) D to input mixer 4 coefficient (default = 1)<br/>u[31:28], D_4[27:24], D_4[23:16], D_4[15:8], D_4[7:0]</b> | <b>0x00, 0x80, 0x00, 0x00</b> |
|               |             | E_to_ipmix[4]        | SDIN3-left (Ch5) E to input mixer 4 coefficient (default = 0)<br>u[31:28], E_4[27:24], E_4[23:16], E_4[15:8], E_4[7:0]          | 0x00, 0x00, 0x00, 0x00        |
|               |             | F_to_ipmix[4]        | SDIN3-right (Ch6) F to input mixer 4 coefficient (default = 0)<br>u[31:28], F_4[27:24], F_4[23:16], F_4[15:8], F_4[7:0]         | 0x00, 0x00, 0x00, 0x00        |
|               |             | G_to_ipmix[4]        | SDIN4-left (Ch7) G to input mixer 4 coefficient (default = 0)<br>u[31:28], G_4[27:24], G_4[23:16], G_4[15:8], G_4[7:0]          | 0x00, 0x00, 0x00, 0x00        |
|               |             | H_to_ipmix[4]        | SDIN4-right (Ch8) H to input mixer 4 coefficient (default = 0)<br>u[31:28], H_4[27:24], H_4[23:16], H_4[15:8], H_4[7:0]         | 0x00, 0x00, 0x00, 0x00        |
| 0x45          | 32          | A_to_ipmix[5]        | SDIN1-left (Ch1) A to input mixer 5 coefficient (default = 0)<br>u[31:28], A_5[27:24], A_5[23:16], A_5[15:8], A_5[7:0]          | 0x00, 0x00, 0x00, 0x00        |
|               |             | B_to_ipmix[5]        | SDIN1-right (Ch2) B to input mixer 5 coefficient (default = 0)<br>u[31:28], B_5[27:24], B_5[23:16], B_5[15:8], B_5[7:0]         | 0x00, 0x00, 0x00, 0x00        |
|               |             | C_to_ipmix[5]        | SDIN2-left (Ch3) C to input mixer 5 coefficient (default = 0)<br>u[31:28], C_5[27:24], C_5[23:16], C_5[15:8], C_5[7:0]          | 0x00, 0x00, 0x00, 0x00        |
|               |             | D_to_ipmix[5]        | SDIN2-right (Ch4) D to input mixer 5 coefficient (default = 0)<br>u[31:28], D_5[27:24], D_5[23:16], D_5[15:8], D_5[7:0]         | 0x00, 0x00, 0x00, 0x00        |
|               |             | <b>E_to_ipmix[5]</b> | <b>SDIN3-left (Ch5) E to input mixer 5 coefficient (default = 1)<br/>u[31:28], E_5[27:24], E_5[23:16], E_5[15:8], E_5[7:0]</b>  | <b>0x00, 0x80, 0x00, 0x00</b> |
|               |             | F_to_ipmix[5]        | SDIN3-right (Ch6) F to input mixer 5 coefficient (default = 0)<br>u[31:28], F_5[27:24], F_5[23:16], F_5[15:8], F_5[7:0]         | 0x00, 0x00, 0x00, 0x00        |
|               |             | G_to_ipmix[5]        | SDIN4-left (Ch7) G to input mixer 5 coefficient (default = 0)<br>u[31:28], G_5[27:24], G_5[23:16], G_5[15:8], G_5[7:0]          | 0x00, 0x00, 0x00, 0x00        |
|               |             | H_to_ipmix[5]        | SDIN4-right (Ch8) H to input mixer 5 coefficient (default = 0)<br>u[31:28], H_5[27:24], H_5[23:16], H_5[15:8], H_5[7:0]         | 0x00, 0x00, 0x00, 0x00        |

Table 7-13. Channel 1–8 Input Mixer Register Format (continued)

| I <sup>2</sup> C SUBADDRESS | TOTAL BYTES | REGISTER FIELDS      | DESCRIPTION OF CONTENTS   | DEFAULT STATE                 |
|-----------------------------|-------------|----------------------|---|-------------------------------|
| 0x46                        | 32          | A_to_ipmix[6]        | SDIN1-left (Ch1) A to input mixer 6 coefficient (default = 0)<br>u[31:28], A_6[27:24], A_6[23:16], A_6[15:8], A_6[7:0]          | 0x00, 0x00, 0x00, 0x00        |
|                             |             | B_to_ipmix[6]        | SDIN1-right (Ch2) B to input mixer 6 coefficient (default = 0)<br>u[31:28], B_6[27:24], B_6[23:16], B_6[15:8], B_6[7:0]         | 0x00, 0x00, 0x00, 0x00        |
|                             |             | C_to_ipmix[6]        | SDIN2-left (Ch3) C to input mixer 6 coefficient (default = 0)<br>u[31:28], C_6[27:24], C_6[23:16], C_6[15:8], C_6[7:0]          | 0x00, 0x00, 0x00, 0x00        |
|                             |             | D_to_ipmix[6]        | SDIN2-right (Ch4) D to input mixer 6 coefficient (default = 0)<br>u[31:28], D_6[27:24], D_6[23:16], D_6[15:8], D_6[7:0]         | 0x00, 0x00, 0x00, 0x00        |
|                             |             | E_to_ipmix[6]        | SDIN3-left (Ch5) E to input mixer 6 coefficient (default = 0)<br>u[31:28], E_6[27:24], E_6[23:16], E_6[15:8], E_6[7:0]          | 0x00, 0x00, 0x00, 0x00        |
|                             |             | <b>F_to_ipmix[6]</b> | <b>SDIN3-right (Ch6) F to input mixer 6 coefficient (default = 1)<br/>u[31:28], F_6[27:24], F_6[23:16], F_6[15:8], F_6[7:0]</b> | <b>0x00, 0x80, 0x00, 0x00</b> |
|                             |             | G_to_ipmix[6]        | SDIN4-left (Ch7) G to input mixer 6 coefficient (default = 0)<br>u[31:28], G_6[27:24], G_6[23:16], G_6[15:8], G_6[7:0]          | 0x00, 0x00, 0x00, 0x00        |
|                             |             | H_to_ipmix[6]        | SDIN4-right (Ch8) H to input mixer 6 coefficient (default = 0)<br>u[31:28], H_6[27:24], H_6[23:16], H_6[15:8], H_6[7:0]         | 0x00, 0x00, 0x00, 0x00        |
| 0x47                        | 32          | A_to_ipmix[7]        | SDIN1-left (Ch1) A to input mixer 7 coefficient (default = 0)<br>u[31:28], A_7[27:24], A_7[23:16], A_7[15:8], A_7[7:0]          | 0x00, 0x00, 0x00, 0x00        |
|                             |             | B_to_ipmix[7]        | SDIN1-right (Ch2) B to input mixer 7 coefficient (default = 0)<br>u[31:28], B_7[27:24], B_7[23:16], B_7[15:8], B_7[7:0]         | 0x00, 0x00, 0x00, 0x00        |
|                             |             | C_to_ipmix[7]        | SDIN2-left (Ch3) C to input mixer 7 coefficient (default = 0)<br>u[31:28], C_7[27:24], C_7[23:16], C_7[15:8], C_7[7:0]          | 0x00, 0x00, 0x00, 0x00        |
|                             |             | D_to_ipmix[7]        | SDIN2-right (Ch4) D to input mixer 7 coefficient (default = 0)<br>u[31:28], D_7[27:24], D_7[23:16], D_7[15:8], D_7[7:0]         | 0x00, 0x00, 0x00, 0x00        |
|                             |             | E_to_ipmix[7]        | SDIN3-left (Ch5) E to input mixer 7 coefficient (default = 0)<br>u[31:28], E_7[27:24], E_7[23:16], E_7[15:8], E_7[7:0]          | 0x00, 0x00, 0x00, 0x00        |
|                             |             | F_to_ipmix[7]        | SDIN3-right (Ch6) F to input mixer 7 coefficient (default = 0)<br>u[31:28], F_7[27:24], F_7[23:16], F_7[15:8], F_7[7:0]         | 0x00, 0x00, 0x00, 0x00        |
|                             |             | <b>G_to_ipmix[7]</b> | <b>SDIN4-left (Ch7) G to input mixer 7 coefficient (default = 1)<br/>u[31:28], G_7[27:24], G_7[23:16], G_7[15:8], G_7[7:0]</b>  | <b>0x00, 0x80, 0x00, 0x00</b> |
|                             |             | H_to_ipmix[7]        | SDIN4-right (Ch8) H to input mixer 7 coefficient (default = 0)<br>u[31:28], H_7[27:24], H_7[23:16], H_7[15:8], H_7[7:0]         | 0x00, 0x00, 0x00, 0x00        |
| 0x48                        | 32          | A_to_ipmix[8]        | SDIN1-left (Ch1) A to input mixer 8 coefficient (default = 0)<br>u[31:28], A_8[27:24], A_8[23:16], A_8[15:8], A_8[7:0]          | 0x00, 0x00, 0x00, 0x00        |
|                             |             | B_to_ipmix[8]        | SDIN1-right (Ch2) B to input mixer 8 coefficient (default = 0)<br>u[31:28], B_8[27:24], B_8[23:16], B_8[15:8], B_8[7:0]         | 0x00, 0x00, 0x00, 0x00        |
|                             |             | C_to_ipmix[8]        | SDIN2-left (Ch3) C to input mixer 8 coefficient (default = 0)<br>u[31:28], C_8[27:24], C_8[23:16], C_8[15:8], C_8[7:0]          | 0x00, 0x00, 0x00, 0x00        |
|                             |             | D_to_ipmix[8]        | SDIN2-right (Ch4) D to input mixer 8 coefficient (default = 0)<br>u[31:28], D_8[27:24], D_8[23:16], D_8[15:8], D_8[7:0]         | 0x00, 0x00, 0x00, 0x00        |
|                             |             | E_to_ipmix[8]        | SDIN3-left (Ch5) E to input mixer 8 coefficient (default = 0)<br>u[31:28], E_8[27:24], E_8[23:16], E_8[15:8], E_8[7:0]          | 0x00, 0x00, 0x00, 0x00        |
|                             |             | F_to_ipmix[8]        | SDIN3-right (Ch6) F to input mixer 8 coefficient (default = 0)<br>u[31:28], F_8[27:24], F_8[23:16], F_8[15:8], F_8[7:0]         | 0x00, 0x00, 0x00, 0x00        |
|                             |             | G_to_ipmix[8]        | SDIN4-left (Ch7) G to input mixer 8 coefficient (default = 0)<br>u[31:28], G_8[27:24], G_8[23:16], G_8[15:8], G_8[7:0]          | 0x00, 0x00, 0x00, 0x00        |
|                             |             | <b>H_to_ipmix[8]</b> | <b>SDIN4-right (Ch8) H to input mixer 8 coefficient (default = 1)<br/>u[31:28], H_8[27:24], H_8[23:16], H_8[15:8], H_8[7:0]</b> | <b>0x00, 0x80, 0x00, 0x00</b> |

## 7.14 Bass Management Registers (0x49–0x50)

Registers 0x49–0x50 provide configuration control for bass management.

Each gain coefficient is in 28-bit (5.23) format, so 0x80 0000 is a gain of 1. Each gain coefficient is written as a 32-bit word with the upper four bits not used.

**Table 7-14. Bass Management Register Format**

| SUB-ADDRESS | TOTAL BYTES | REGISTER NAME   | DESCRIPTION OF CONTENTS   | DEFAULT STATE          |
|-------------|-------------|-----------------|---|------------------------|
| 0x49        | 4           | ipmix_1_to_ch8  | Input mixer 1 to Ch8 mixer coefficient (default = 0)<br>u[31:28], ipmix18[27:24], ipmix18[23:16], ipmix18[15:8],<br>ipmix18[7:0]                                | 0x00, 0x00, 0x00, 0x00 |
| 0x4A        | 4           | ipmix_2_to_ch8  | Input mixer 2 to Ch8 mixer coefficient (default = 0)<br>u[31:28], ipmix28[27:24], ipmix28[23:16], ipmix28[15:8],<br>ipmix28[7:0]                                | 0x00, 0x00, 0x00, 0x00 |
| 0x4B        | 4           | ipmix_7_to_ch12 | Input mixer 7 to Ch1 and Ch2 mixer coefficient (default = 0)<br>u[31:28], ipmix72[27:24], ipmix72[23:16], ipmix72[15:8],<br>ipmix72[7:0]                        | 0x00, 0x00, 0x00, 0x00 |
| 0x4C        | 4           | Ch7_bp_bq2      | Ch7 biquad-2 bypass coefficient (default = 0)<br>u[31:28], ch7_bp_bq2[27:24], ch7_bp_bq2[23:16],<br>ch7_bp_bq2[15:8], ch7_bp_bq2[7:0]                           | 0x00, 0x00, 0x00, 0x00 |
| 0x4D        | 4           | Ch7_bq2         | Ch7 biquad-2 inline coefficient (default = 1)<br>u[31:28], ch6_bq2[27:24], ch6_bq2[23:16], ch6_bq2[15:8],<br>ch6_bq2[7:0]                                       | 0x00, 0x80, 0x00, 0x00 |
| 0x4E        | 4           | ipmix_8_to_ch12 | Ch8 biquad-2 output to Ch1 mixer and Ch2 mixer coefficient<br>(default = 0)<br>u[31:28], ipmix8_12[27:24], ipmix8_12[23:16],<br>ipmix8_12[15:8], ipmix8_12[7:0] | 0x00, 0x00, 0x00, 0x00 |
| 0x4F        | 4           | Ch8_bp_bq2      | Ch8 biquad-2 bypass coefficient (default = 0)<br>u[31:28], ch8_bp_bq2[27:24], ch8_bp_bq2[23:16],<br>ch8_bp_bq2[15:8], ch8_bp_bq2[7:0]                           | 0x00, 0x00, 0x00, 0x00 |
| 0x50        | 4           | Ch8_bq2         | Ch8 biquad-2 inline coefficient (default = 1)<br>u[31:28], ch7_bq2[27:24], ch7_bq2[23:16], ch7_bq2[15:8],<br>ch7_bq2[7:0]                                       | 0x00, 0x80, 0x00, 0x00 |

## 7.15 Biquad Filter Register (0x51–0x88)

**Table 7-15. Biquad Filter Register Format**

| I <sup>2</sup> C SUBADDRESS | TOTAL BYTES | REGISTER NAME | DESCRIPTION OF CONTENTS   | DEFAULT STATE                  |
|-----------------------------|-------------|---------------|---|--------------------------------|
| 0x51–0x57                   | 20/reg.     | Ch1_bq[1:7]   | Ch1 biquads 1–7. See <a href="#">Table 7-16</a> for bit definition. | See <a href="#">Table 7-16</a> |
| 0x58–0x5E                   | 20/reg.     | Ch2_bq[1:7]   | Ch2 biquads 1–7. See <a href="#">Table 7-16</a> for bit definition. | See <a href="#">Table 7-16</a> |
| 0x5F–0x65                   | 20/reg.     | Ch3_bq[1:7]   | Ch3 biquads 1–7. See <a href="#">Table 7-16</a> for bit definition. | See <a href="#">Table 7-16</a> |
| 0x66–0x6C                   | 20/reg.     | Ch4_bq[1:7]   | Ch4 biquads 1–7. See <a href="#">Table 7-16</a> for bit definition. | See <a href="#">Table 7-16</a> |
| 0x6D–0x73                   | 20/reg.     | Ch5_bq[1:7]   | Ch5 biquads 1–7. See <a href="#">Table 7-16</a> for bit definition. | See <a href="#">Table 7-16</a> |
| 0x74–0x7A                   | 20/reg.     | Ch6_bq[1:7]   | Ch6 biquads 1–7. See <a href="#">Table 7-16</a> for bit definition. | See <a href="#">Table 7-16</a> |
| 0x7B–0x81                   | 20/reg.     | Ch7_bq[1:7]   | Ch7 biquads 1–7. See <a href="#">Table 7-16</a> for bit definition. | See <a href="#">Table 7-16</a> |
| 0x82–0x88                   | 20/reg.     | Ch8_bq[1:7]   | Ch8 biquads 1–7. See <a href="#">Table 7-16</a> for bit definition. | See <a href="#">Table 7-16</a> |

Each gain coefficient is in 28-bit (5.23) format, so 0x80 0000 is a gain of 1. Each gain coefficient is written as a 32-bit word with the upper four bits not used.

**Table 7-16. Contents of One 20-Byte Biquad Filter Register (Default = All-Pass)**

| DESCRIPTION                | REGISTER FIELD CONTENTS                           | DEFAULT GAIN COEFFICIENT VALUES |                        |
|----------------------------|---|---------------------------------|------------------------|
|                            |   | DECIMAL                         | HEX                    |
| b <sub>0</sub> coefficient | u[31:28], b0[27:24], b0[23:16], b0[15:8], b0[7:0] | 1.0                             | 0x00, 0x80, 0x00, 0x00 |
| b <sub>1</sub> coefficient | u[31:28], b1[27:24], b1[23:16], b1[15:8], b1[7:0] | 0.0                             | 0x00, 0x00, 0x00, 0x00 |
| b <sub>2</sub> coefficient | u[31:28], b2[27:24], b2[23:16], b2[15:8], b2[7:0] | 0.0                             | 0x00, 0x00, 0x00, 0x00 |
| a <sub>1</sub> coefficient | u[31:28], a1[27:24], a1[23:16], a1[15:8], a1[7:0] | 0.0                             | 0x00, 0x00, 0x00, 0x00 |
| a <sub>2</sub> coefficient | u[31:28], a2[27:24], a2[23:16], a2[15:8], a2[7:0] | 0.0                             | 0x00, 0x00, 0x00, 0x00 |

### 7.16 Bass and Treble Bypass Register, Channels 1–8 (0x89–0x90)

Channels 1, 2, 3, 4, 5, 6, 7, and 8 are mapped into registers 0x89, 0x8A, 0x8B, 0x8C, 0x8D, 0x8E, 0x8F, and 0x90, respectively. Eight bytes are written for each channel. Each gain coefficient is in 28-bit (5.23) format, so 0x80 0000 is a gain of 1. Each gain coefficient is written as a 32-bit word with the upper four bits not used.

**Table 7-17. Channel 1–8 Bass and Treble Bypass Register Format**

| REGISTER NAME                  | TOTAL BYTES | CONTENTS  | DEFAULT VALUE          |
|--------------------------------|-------------|---|------------------------|
| Channel bass and treble bypass | 8           | u[31:28], bypass[27:24], bypass[23:16], bypass[15:8], bypass[7:0] | 0x00, 0x80, 0x00, 0x00 |
| Channel bass and treble inline |             | u[31:28], inline[27:24], inline[23:16], inline[15:8], inline[7:0] | 0x00, 0x00, 0x00, 0x00 |

### 7.17 Loudness Registers (0x91–0x95)

**Table 7-18. Loudness Register Format**

| I <sup>2</sup> C SUB-ADDRESS | TOTAL BYTES | REGISTER NAME                     | DESCRIPTION OF CONTENTS                           | DEFAULT STATE          |
|------------------------------|-------------|-----------------------------------|---|------------------------|
| 0x91                         | 4           | Loudness Log2 gain (LG)           | u[31:28], LG[27:24], LG[23:16], LG[15:8], LG[7:0] | 0xFF, 0xC0, 0x00, 0x00 |
| 0x92                         | 8           | Loudness Log2 offset (LO)         | u[31:24], u[23:16], LO[15:8], LO[7:0]             | 0x00, 0x00, 0x00, 0x00 |
|                              |             | Loudness Log2 offset (LO)         | LO[31:24], LO[23:16], LO[15:8], LO[7:0]           | 0x00, 0x00, 0x00, 0x00 |
| 0x93                         | 4           | Loudness gain (G)                 | u[31:28], G[27:24], G[23:16], G[15:8], G[7:0]     | 0x00, 0x00, 0x00, 0x00 |
| 0x94                         | 8           | Loudness offset upper 16 bits (O) | u[31:24], u[23:16], O[15:8], O[7:0]               | 0x00, 0x00, 0x00, 0x00 |
|                              |             | Loudness offset lower 32 bits (O) | O[31:24], O[23:16], O[15:8], O[7:0]               | 0x00, 0x00, 0x00, 0x00 |
| 0x95                         | 20          | Loudness biquad (b <sub>0</sub> ) | u[31:28], b0[27:24], b0[23:16], b0[15:8], b0[7:0] | 0x00, 0x00, 0xD5, 0x13 |
|                              |             | Loudness biquad (b <sub>1</sub> ) | u[31:28], b1[27:24], b1[23:16], b1[15:8], b1[7:0] | 0x00, 0x00, 0x00, 0x00 |
|                              |             | Loudness biquad (b <sub>2</sub> ) | u[31:28], b2[27:24], b2[23:16], b2[15:8], b2[7:0] | 0x0F, 0xFF, 0x2A, 0xED |
|                              |             | Loudness biquad (a <sub>1</sub> ) | u[31:28], a1[27:24], a1[23:16], a1[15:8], a1[7:0] | 0x00, 0xFE, 0x50, 0x45 |
|                              |             | Loudness biquad (a <sub>2</sub> ) | u[31:28], a2[27:24], a2[23:16], a2[15:8], a2[7:0] | 0x0F, 0x81, 0xAA, 0x27 |

## 7.18 DRC1 Control Registers, Channels 1–7 (0x96)

Bits D31–D14 are *don't care*. Note that there must be a 10-ms delay between a write to register 0x96 and a write to register 0x97.

Table 7-19. Channel 1–7 DCR1 Control Register Format

| D31 | D30 | D29 | D28 | D27 | D26 | D25 | D24 | FUNCTION                          |
|-----|-----|-----|-----|-----|-----|-----|-----|-----------------------------------|
|     |     |     |     |     |     |     |     | Unused bits                       |
| D23 | D22 | D21 | D20 | D19 | D18 | D17 | D16 | FUNCTION                          |
|     |     |     |     |     |     |     |     | Unused bits                       |
| D15 | D14 | D13 | D12 | D11 | D10 | D9  | D8  | FUNCTION                          |
|     |     | 0   | 0   | –   | –   | –   | –   | <b>Channel 1 (node j): No DRC</b> |
|     |     | 0   | 1   | –   | –   | –   | –   | Channel 1: Pre-volume DRC         |
|     |     | 1   | 0   | –   | –   | –   | –   | Channel 1: Post-volume DRC        |
|     |     | 1   | 1   | –   | –   | –   | –   | Channel 1: No DRC                 |
|     |     | –   | –   | 0   | 0   | –   | –   | <b>Channel 2: No DRC</b>          |
|     |     | –   | –   | 0   | 1   | –   | –   | Channel 2: Pre-volume DRC         |
|     |     | –   | –   | 1   | 0   | –   | –   | Channel 2: Post-volume DRC        |
|     |     | –   | –   | 1   | 1   | –   | –   | Channel 2: No DRC                 |
|     |     | –   | –   | –   | –   | 0   | 0   | <b>Channel 3: No DRC</b>          |
|     |     | –   | –   | –   | –   | 0   | 1   | Channel 3: Pre-volume DRC         |
|     |     | –   | –   | –   | –   | 1   | 0   | Channel 3: Post-volume DRC        |
|     |     | –   | –   | –   | –   | 1   | 1   | Channel 3: No DRC                 |
| D7  | D6  | D5  | D4  | D3  | D2  | D1  | D0  | FUNCTION                          |
| 0   | 0   | –   | –   | –   | –   | –   | –   | <b>Channel 4: No DRC</b>          |
| 0   | 1   | –   | –   | –   | –   | –   | –   | Channel 4: Pre-volume DRC         |
| 1   | 0   | –   | –   | –   | –   | –   | –   | Channel 4: Post-volume DRC        |
| 1   | 1   | –   | –   | –   | –   | –   | –   | Channel 4: No DRC                 |
| –   | –   | 0   | 0   | –   | –   | –   | –   | <b>Channel 5: No DRC</b>          |
| –   | –   | 0   | 1   | –   | –   | –   | –   | Channel 5: Pre-volume DRC         |
| –   | –   | 1   | 0   | –   | –   | –   | –   | Channel 5: Post-volume DRC        |
| –   | –   | 1   | 1   | –   | –   | –   | –   | Channel 5: No DRC                 |
| –   | –   | –   | –   | 0   | 0   | –   | –   | <b>Channel 6: No DRC</b>          |
| –   | –   | –   | –   | 0   | 1   | –   | –   | Channel 6: Pre-volume DRC         |
| –   | –   | –   | –   | 1   | 0   | –   | –   | Channel 6: Post-volume DRC        |
| –   | –   | –   | –   | 1   | 1   | –   | –   | Channel 6: No DRC                 |
| –   | –   | –   | –   | –   | –   | 0   | 0   | <b>Channel 7: No DRC</b>          |
| –   | –   | –   | –   | –   | –   | 0   | 1   | Channel 7: Pre-volume DRC         |
| –   | –   | –   | –   | –   | –   | 1   | 0   | Channel 7: Post-volume DRC        |
| –   | –   | –   | –   | –   | –   | 1   | 1   | Channel 7: No DRC                 |

## 7.19 DRC2 Control Register, Channel 8 (0x97)

Note that there must be a 10-ms delay between a write to register 0x96 and a write to register 0x97.

**Table 7-20. Channel-8 DRC2 Control Register Format**

| D31–D2 |   | D1 | D0 | FUNCTION                            |
|--------|---|----|----|-------------------------------------|
| 0      | 0 | 0  | 0  | Channel 8 (node r): no DRC          |
| 0      | 0 | 0  | 1  | Channel 8 (node r): pre-volume DRC  |
| 0      | 0 | 1  | 0  | Channel 8 (node r): post-volume DRC |
| 0      | 0 | 1  | 1  | Channel 8 (node r): no DRC          |

## 7.20 DRC1 Data Registers (0x98–0x9C)

DRC1 applies to channels 1, 2, 3, 4, 5, 6, and 7.

**Table 7-21. DRC1 Data Register Format**

| I <sup>2</sup> C SUB-ADDRESS | TOTAL BYTES | REGISTER NAME   | DESCRIPTION OF CONTENTS                               | DEFAULT STATE          |
|------------------------------|-------------|---|---|------------------------|
| 0x98                         | 8           | Channel 1, 2, 3, 4, 5, 6, and 7 DRC1 energy                       | u[31:28], E[27:24], E[23:16], E[15:8], E[7:0]         | 0x00, 0x00, 0x88, 0x3F |
|                              |             | Channel 1, 2, 3, 4, 5, 6, and 7 DRC1 (1 – energy)                 | u[31:28], 1–E[27:24], 1–E[23:16], 1–E[15:8], 1–E[7:0] | 0x00, 0x7F, 0x77, 0xC0 |
| 0x99                         | 16          | Channel 1, 2, 3, 4, 5, 6, and 7 DRC1 threshold upper 16 bits (T1) | u[31:24], u[23:16], T1[15:8], T1[7:0]                 | 0x00, 0x00, 0x00, 0x00 |
|                              |             | Channel 1, 2, 3, 4, 5, 6, and 7 DRC1 threshold lower 32 bits (T1) | T1[31:24], T1[23:16], T1[15:8], T1[7:0]               | 0x0B, 0x20, 0xE2, 0xB2 |
|                              |             | Channel 1, 2, 3, 4, 5, 6, and 7 DRC1 threshold upper 16 bits (T2) | u[31:24], u[23:16], T2[15:8], T2[7:0]                 | 0x00, 0x00, 0x00, 0x00 |
|                              |             | Channel 1, 2, 3, 4, 5, 6, and 7 DRC1 threshold lower 32 bits (T2) | T2[31:24], T2[23:16], T2[15:8], T2[7:0]               | 0x06, 0xF9, 0xDE, 0x58 |
| 0x9A                         | 12          | Channel 1, 2, 3, 4, 5, 6, and 7 DRC1 slope (k0)                   | u[31:28], k0[27:24], k0[23:16], k0[15:8], k0[7:0]     | 0x00, 0x40, 0x00, 0x00 |
|                              |             | Channel 1, 2, 3, 4, 5, 6, and 7 DRC1 slope (k1)                   | u[31:28], k1[27:24], k1[23:16], k1[15:8], k1[7:0]     | 0x0F, 0xC0, 0x00, 0x00 |
|                              |             | Channel 1, 2, 3, 4, 5, 6, and 7 DRC1 slope (k2)                   | u[31:28], k2[27:24], k2[23:16], k2[15:8], k2[7:0]     | 0x0F, 0x90, 0x00, 0x00 |
| 0x9B                         | 16          | Channel 1, 2, 3, 4, 5, 6, and 7 DRC1 offset-1 upper 16 bits (O1)  | u[31:24], u[23:16], O1[15:8], O1[7:0]                 | 0x00, 0x00, 0xFF, 0xFF |
|                              |             | Channel 1, 2, 3, 4, 5, 6, and 7 DRC1 offset-1 lower 32 bits (O1)  | O1[31:24], O1[23:16], O1[15:8], O1[7:0]               | 0xFF, 0x82, 0x30, 0x98 |
|                              |             | Channel 1, 2, 3, 4, 5, 6, and 7 DRC1 offset-2 upper 16 bits (O2)  | u[31:24], u[23:16], O2[15:8], O2[7:0]                 | 0x00, 0x00, 0x00, 0x00 |
|                              |             | Channel 1, 2, 3, 4, 5, 6, and 7 DRC1 offset-2 lower 32 bits (O2)  | O2[31:24], O2[23:16], O2[15:8], O2[7:0]               | 0x01, 0x95, 0xB2, 0xC0 |
| 0x9C                         | 16          | Channel 1, 2, 3, 4, 5, 6, and 7 DRC1 attack                       | u[31:28], A[27:24], A[23:16], A[15:8], A[7:0]         | 0x00, 0x00, 0x88, 0x3F |
|                              |             | Channel 1, 2, 3, 4, 5, 6, and 7 DRC1 (1 – attack)                 | u[31:28], 1–A[27:24], 1–A[23:16], 1–A[15:8], 1–A[7:0] | 0x00, 0x7F, 0x77, 0xC0 |
|                              |             | Channel 1, 2, 3, 4, 5, 6, and 7 DRC1 decay                        | u[31:28], D[27:24], D[23:16], D[15:8], D[7:0]         | 0x00, 0x00, 0x00, 0x56 |
|                              |             | Channel 1, 2, 3, 4, 5, 6, and 7 DRC1 (1 – decay)                  | u[31:28], 1–D[27:24], 1–D[23:16], 1–D[15:8], 1–D[7:0] | 0x00, 0x3F, 0xFF, 0xA8 |



## 7.21 DRC2 Data Registers (0x9D–0xA1)

DRC2 applies to channel 8.

Table 7-22. DRC2 Data Register Format

| I <sup>2</sup> C SUBADDRESS | TOTAL BYTES | REGISTER NAME                               | DESCRIPTION OF CONTENTS                               | DEFAULT STATE          |
|-----------------------------|-------------|---|---|------------------------|
| 0x9D                        | 8           | Channel 8 DRC2 energy                       | u[31:28], E[27:24], E[23:16], E[15:8], E[7:0]         | 0x00, 0x00, 0x88, 0x3F |
|                             |             | Channel 8 DRC2 (1 – energy)                 | u[31:28], 1–E[27:24], 1–E[23:16], 1–E[15:8], 1–E[7:0] | 0x00, 0x7F, 0x77, 0xC0 |
| 0x9E                        | 16          | Channel 8 DRC2 threshold upper 16 bits (T1) | u[31:24], u[23:16], T1[15:8], T1[7:0]                 | 0x00, 0x00, 0x00, 0x00 |
|                             |             | Channel 8 DRC2 threshold lower 32 bits (T1) | T1[31:24], T1[23:16], T1[15:8], T1[7:0]               | 0x0B, 0x20, 0xE2, 0xB2 |
|                             |             | Channel 8 DRC2 threshold upper 16 bits (T2) | u[31:24], u[23:16], T2[15:8], T2[7:0]                 | 0x00, 0x00, 0x00, 0x00 |
|                             |             | Channel 8 DRC2 threshold lower 32 bits (T2) | T2[31:24], T2[23:16], T2[15:8], T2[7:0]               | 0x06, 0xF9, 0xDE, 0x58 |
| 0x9F                        | 12          | Channel 8 DRC2 slope (k0)                   | u[31:28], k0[27:24], k0[23:16], k0[15:8], k0[7:0]     | 0x00, 0x40, 0x00, 0x00 |
|                             |             | Channel 8 DRC2 slope (k1)                   | u[31:28], k1[27:24], k1[23:16], k1[15:8], k1[7:0]     | 0x0F, 0xC0, 0x00, 0x00 |
|                             |             | Channel 8 DRC2 slope (k2)                   | u[31:28], k2[27:24], k2[23:16], k2[15:8], k2[7:0]     | 0x0F, 0x90, 0x00, 0x00 |
| 0xA0                        | 16          | Channel 8 DRC2 offset 1 upper 16 bits (O1)  | u[31:24], u[23:16], O1[15:8], O1[7:0]                 | 0x00, 0x00, 0xFF, 0xFF |
|                             |             | Channel 8 DRC2 offset 1 lower 32 bits (O1)  | O1[31:24], O1[23:16], O1[15:8], O1[7:0]               | 0xFF, 0x82, 0x30, 0x98 |
|                             |             | Channel 8 DRC2 offset 2 upper 16 bits (O2)  | u[31:24], u[23:16], O2[15:8], O2[7:0]                 | 0x00, 0x00, 0x00, 0x00 |
|                             |             | Channel 8 DRC2 offset 2 lower 32 bits (O2)  | O2[31:24], O2[23:16], O2[15:8], O2[7:0]               | 0x01, 0x95, 0xB2, 0xC0 |
| 0xA1                        | 16          | Channel 8 DRC2 attack                       | u[31:28], A[27:24], A[23:16], A[15:8], A[7:0]         | 0x00, 0x00, 0x88, 0x3F |
|                             |             | Channel 8 DRC2 (1 – attack)                 | u[31:28], 1–A[27:24], 1–A[23:16], 1–A[15:8], 1–A[7:0] | 0x00, 0x7F, 0x77, 0xC0 |
|                             |             | Channel 8 DRC2 decay                        | u[31:28], D[27:24], D[23:16], D[15:8], D[7:0]         | 0x00, 0x00, 0x00, 0x56 |
|                             |             | Channel 8 DRC2 (1 – decay)                  | u[31:28], 1–D[27:24], 1–D[23:16], 1–D[15:8], 1–D[7:0] | 0x00, 0x3F, 0xFF, 0xA8 |

## 7.22 DRC Bypass Registers (0xA2–0xA9)

DRC bypass/inline for channels 1, 2, 3, 4, 5, 6, 7, and 8 are mapped into registers 0xA2, 0xA3, 0xA4, 0xA5, 0xA6, 0xA7, 0xA8, and 0xA9, respectively. Eight bytes are written for each channel. Each gain coefficient is in 28-bit (5.23) format, so 0x0080 0000 is a gain of 1. Each gain coefficient is written as a 32-bit word with the upper 4 bits not used.

To enable DRC for a given channel (with unity gain), bypass = 0x0000 0000 and inline = 0x0080 0000.

To disable DRC for a given channel, bypass = 0x0080 0000 and inline = 0x0000 0000.

Table 7-23. DRC Bypass Register Format

| REGISTER NAME           | TOTAL BYTES | CONTENTS  | DEFAULT VALUE          |
|-------------------------|-------------|---|------------------------|
| Channel bass DRC bypass | 8           | u[31:28], bypass[27:24], bypass[23:16], bypass[15:8], bypass[7:0] | 0x00, 0x80, 0x00, 0x00 |
| Channel DRC inline      |             | u[31:28], inline[27:24], inline[23:16], inline[15:8], inline[7:0] | 0x00, 0x00, 0x00, 0x00 |

## 7.23 8×2 Output Mixer Registers (0xAA–0xAF)

The pass-through output mixer setting is:

- DAP channel 1 is mapped through the 8×2 crossbar mixer (0xAA) to PWM channel 1
- DAP channel 2 is mapped through the 8×2 crossbar mixer (0xAB) to PWM channel 2
- DAP channel 3 is mapped through the 8×2 crossbar mixer (0xAC) to PWM channel 3

- DAP channel 4 is mapped though the 8x2 crossbar mixer (0xAD) to PWM channel 4
- DAP channel 5 is mapped though the 8x2 crossbar mixer (0xAE) to PWM channel 5
- DAP channel 6 is mapped though the 8x2 crossbar mixer (0xAF) to PWM channel 6

Note that the pass-through output mixer configuration (0xD0 bit 30 = 1) is recommended. Using the remapped output mixer configuration (0xD0 bit 30 = 0) increases the complexity of using some features such as volume and mute. See *TAS5508B Errata* ([SLEZ006](#)).

Total data per register is 8 bytes. The default gain for each selected channel is 1 (0x0 80 00 00).

**Table 7-24. Output Mixer Register Format (Upper 4 Bytes)**

| D31 | D30 | D29 | D28 | D27 | D26 | D25 | D24 | FUNCTION                             |
|-----|-----|-----|-----|-----|-----|-----|-----|--------------------------------------|
| 0   | 0   | 0   | 0   |     |     |     |     | Select channel 1 to output mixer     |
| 0   | 0   | 0   | 1   |     |     |     |     | Select channel 2 to output mixer     |
| 0   | 0   | 1   | 0   |     |     |     |     | Select channel 3 to output mixer     |
| 0   | 0   | 1   | 1   |     |     |     |     | Select channel 4 to output mixer     |
| 0   | 1   | 0   | 0   |     |     |     |     | Select channel 5 to output mixer     |
| 0   | 1   | 0   | 1   |     |     |     |     | Select channel 6 to output mixer     |
| 0   | 1   | 1   | 0   |     |     |     |     | Select channel 7 to output mixer     |
| 0   | 1   | 1   | 1   |     |     |     |     | Select channel 8 to output mixer     |
|     |     |     |     | G27 | G26 | G25 | G24 | Selected channel gain (upper 4 bits) |
| D23 | D22 | D21 | D20 | D19 | D18 | D17 | D16 | FUNCTION                             |
| G23 | G22 | G21 | G20 | G19 | G18 | G17 | G16 | Selected channel gain (continued)    |
| D15 | D14 | D13 | D12 | D11 | D10 | D9  | D8  | FUNCTION                             |
| G15 | G14 | G13 | G12 | G11 | G10 | G9  | G8  | Selected channel gain (continued)    |
| D7  | D6  | D5  | D4  | D3  | D2  | D1  | D0  | FUNCTION                             |
| G7  | G6  | G5  | G4  | G3  | G2  | G1  | G0  | Selected channel gain (lower 8 bits) |

**Table 7-25. Output Mixer Register Format (Lower 4 Bytes)**

| D31 | D30 | D29 | D28 | D27 | D26 | D25 | D24 | FUNCTION                             |
|-----|-----|-----|-----|-----|-----|-----|-----|--------------------------------------|
| 0   | 0   | 0   | 0   |     |     |     |     | Select channel 1 to output mixer     |
| 0   | 0   | 0   | 1   |     |     |     |     | Select channel 2 to output mixer     |
| 0   | 0   | 1   | 0   |     |     |     |     | Select channel 3 to output mixer     |
| 0   | 0   | 1   | 1   |     |     |     |     | Select channel 4 to output mixer     |
| 0   | 1   | 0   | 0   |     |     |     |     | Select channel 5 to output mixer     |
| 0   | 1   | 0   | 1   |     |     |     |     | Select channel 6 to output mixer     |
| 0   | 1   | 1   | 0   |     |     |     |     | Select channel 7 to output mixer     |
| 0   | 1   | 1   | 1   |     |     |     |     | Select channel 8 to output mixer     |
|     |     |     |     | G27 | G26 | G25 | G24 | Selected channel gain (upper 4 bits) |
| D23 | D22 | D21 | D20 | D19 | D18 | D17 | D16 | FUNCTION                             |
| G23 | G22 | G21 | G20 | G19 | G18 | G17 | G16 | Selected channel gain (continued)    |
| D15 | D14 | D13 | D12 | D11 | D10 | D9  | D8  | FUNCTION                             |
| G15 | G14 | G13 | G12 | G11 | G10 | G9  | G8  | Selected channel gain (continued)    |
| D7  | D6  | D5  | D4  | D3  | D2  | D1  | D0  | FUNCTION                             |
| G7  | G6  | G5  | G4  | G3  | G2  | G1  | G0  | Selected channel gain (lower 8 bits) |

## 7.24 8×3 Output Mixer Registers (0xB0–0xB1)

The pass-through output mixer setting is:

- DAP channel 7 is mapped through the 8×3 crossbar mixer (0xB0) to PWM channel 7
- DAP channel 8 is mapped through the 8×3 crossbar mixer (0xB1) to PWM channel 8

Note that the default setting is recommended for most systems. Any variation from this setting increases the complexity of using some features such as volume and mute. See *TAS5508B Errata* ([SLEZ006](#)).

Total data per register is 12 bytes. The default gain for each selected channel is 1 (0x0080 0000).

**Table 7-26. Output Mixer Register Format (Upper 4 Bytes)**

| D31 | D30 | D29 | D28 | D27 | D26 | D25 | D24 | FUNCTION                             |
|-----|-----|-----|-----|-----|-----|-----|-----|--------------------------------------|
| 0   | 0   | 0   | 0   |     |     |     |     | Select channel 1 to output mixer     |
| 0   | 0   | 0   | 1   |     |     |     |     | Select channel 2 to output mixer     |
| 0   | 0   | 1   | 0   |     |     |     |     | Select channel 3 to output mixer     |
| 0   | 0   | 1   | 1   |     |     |     |     | Select channel 4 to output mixer     |
| 0   | 1   | 0   | 0   |     |     |     |     | Select channel 5 to output mixer     |
| 0   | 1   | 0   | 1   |     |     |     |     | Select channel 6 to output mixer     |
| 0   | 1   | 1   | 0   |     |     |     |     | Select channel 7 to output mixer     |
| 0   | 1   | 1   | 1   |     |     |     |     | Select channel 8 to output mixer     |
|     |     |     |     | G27 | G26 | G25 | G24 | Selected channel gain (upper 4 bits) |
| D23 | D22 | D21 | D20 | D19 | D18 | D17 | D16 | FUNCTION                             |
| G23 | G22 | G21 | G20 | G19 | G18 | G17 | G16 | Selected channel gain (continued)    |
| D15 | D14 | D13 | D12 | D11 | D10 | D9  | D8  | FUNCTION                             |
| G15 | G14 | G13 | G12 | G11 | G10 | G9  | G8  | Selected channel gain (continued)    |
| D7  | D6  | D5  | D4  | D3  | D2  | D1  | D0  | FUNCTION                             |
| G7  | G6  | G5  | G4  | G3  | G2  | G1  | G0  | Selected channel gain (lower 8 bits) |

**Table 7-27. Output Mixer Register Format (Middle 4 Bytes)**

| D31 | D30 | D29 | D28 | D27 | D26 | D25 | D24 | FUNCTION                             |
|-----|-----|-----|-----|-----|-----|-----|-----|--------------------------------------|
| 0   | 0   | 0   | 0   |     |     |     |     | Select channel 1 to output mixer     |
| 0   | 0   | 0   | 1   |     |     |     |     | Select channel 2 to output mixer     |
| 0   | 0   | 1   | 0   |     |     |     |     | Select channel 3 to output mixer     |
| 0   | 0   | 1   | 1   |     |     |     |     | Select channel 4 to output mixer     |
| 0   | 1   | 0   | 0   |     |     |     |     | Select channel 5 to output mixer     |
| 0   | 1   | 0   | 1   |     |     |     |     | Select channel 6 to output mixer     |
| 0   | 1   | 1   | 0   |     |     |     |     | Select channel 7 to output mixer     |
| 0   | 1   | 1   | 1   |     |     |     |     | Select channel 8 to output mixer     |
|     |     |     |     | G27 | G26 | G25 | G24 | Selected channel gain (upper 4 bits) |
| D23 | D22 | D21 | D20 | D19 | D18 | D17 | D16 | FUNCTION                             |
| G23 | G22 | G21 | G20 | G19 | G18 | G17 | G16 | Selected channel gain (continued)    |
| D15 | D14 | D13 | D12 | D11 | D10 | D9  | D8  | FUNCTION                             |
| G15 | G14 | G13 | G12 | G11 | G10 | G9  | G8  | Selected channel gain (continued)    |
| D7  | D6  | D5  | D4  | D3  | D2  | D1  | D0  | FUNCTION                             |
| G7  | G6  | G5  | G4  | G3  | G2  | G1  | G0  | Selected channel gain (lower 8 bits) |

**Table 7-28. Output Mixer Register Format (Lower 4 Bytes)**

| D31 | D30 | D29 | D28 | D27 | D26 | D25 | D24 | FUNCTION                             |
|-----|-----|-----|-----|-----|-----|-----|-----|--------------------------------------|
| 0   | 0   | 0   | 0   |     |     |     |     | Select channel 1 to output mixer     |
| 0   | 0   | 0   | 1   |     |     |     |     | Select channel 2 to output mixer     |
| 0   | 0   | 1   | 0   |     |     |     |     | Select channel 3 to output mixer     |
| 0   | 0   | 1   | 1   |     |     |     |     | Select channel 4 to output mixer     |
| 0   | 1   | 0   | 0   |     |     |     |     | Select channel 5 to output mixer     |
| 0   | 1   | 0   | 1   |     |     |     |     | Select channel 6 to output mixer     |
| 0   | 1   | 1   | 0   |     |     |     |     | Select channel 7 to output mixer     |
| 0   | 1   | 1   | 1   |     |     |     |     | Select channel 8 to output mixer     |
|     |     |     |     | G27 | G26 | G25 | G24 | Selected channel gain (upper 4 bits) |
| D23 | D22 | D21 | D20 | D19 | D18 | D17 | D16 | FUNCTION                             |
| G23 | G22 | G21 | G20 | G19 | G18 | G17 | G16 | Selected channel gain (continued)    |
| D15 | D14 | D13 | D12 | D11 | D10 | D9  | D8  | FUNCTION                             |
| G15 | G14 | G13 | G12 | G11 | G10 | G9  | G8  | Selected channel gain (continued)    |
| D7  | D6  | D5  | D4  | D3  | D2  | D1  | D0  | FUNCTION                             |
| G7  | G6  | G5  | G4  | G3  | G2  | G1  | G0  | Selected channel gain (lower 8 bits) |

### 7.25 PSVC Volume Biquad Register (0xCF)

Each gain coefficient is in 28-bit (5.23) format, so 0x80 0000 is a gain of 1. Each gain coefficient is written as a 32-bit word with the upper four bits not used. Note that this register should be used only with the PSVC feature its use is not required. For systems not using this feature, it is recommended that this biquad be set to all-pass (default).

**Table 7-29. Volume Biquad Register Format (Default = All-Pass)**

| DESCRIPTION                | REGISTER FIELD CONTENTS                           | DEFAULT GAIN COEFFICIENT VALUES |                        |
|----------------------------|---|---------------------------------|------------------------|
|                            |   | DECIMAL                         | HEX                    |
| b <sub>0</sub> coefficient | u[31:28], b0[27:24], b0[23:16], b0[15:8], b0[7:0] | 1.0                             | 0x00, 0x80, 0x00, 0x00 |
| b <sub>1</sub> coefficient | u[31:28], b1[27:24], b1[23:16], b1[15:8], b1[7:0] | 0.0                             | 0x00, 0x00, 0x00, 0x00 |
| b <sub>2</sub> coefficient | u[31:28], b2[27:24], b2[23:16], b2[15:8], b2[7:0] | 0.0                             | 0x00, 0x00, 0x00, 0x00 |
| a <sub>1</sub> coefficient | u[31:28], a1[27:24], a1[23:16], a1[15:8], a1[7:0] | 0.0                             | 0x00, 0x00, 0x00, 0x00 |
| a <sub>2</sub> coefficient | u[31:28], a2[27:24], a2[23:16], a2[15:8], a2[7:0] | 0.0                             | 0x00, 0x00, 0x00, 0x00 |

## 7.26 Volume, Treble, and Bass Slew Rates Register (0xD0)

If using pass-through output mixer configuration, bit D30 must to be set to 1 after reset. For remapped output mixer configuration, this bit must be left in the default state (0).

**Table 7-30. Volume Gain Update Rate (Slew Rate)**

| D31 | D30 | D29-D10 | D9 | D8 | FUNCTION  |
|-----|-----|---------|----|----|---|
| 0   | 0   | 0       | x  | x  | Remapped output mixer configuration (not recommended)         |
| 0   | 1   | 0       | x  | x  | Pass-through output mixer configuration (recommended)         |
| 0   |     | 0       | 0  | 0  | 512-step update at 4 f <sub>S</sub> , 42.6 ms at 48 kHz       |
| 0   |     | 0       | 0  | 1  | <b>1024-step update at 4 f<sub>S</sub>, 85.3 ms at 48 kHz</b> |
| 0   |     | 0       | 1  | 0  | 2048-step update at 4 f <sub>S</sub> , 170 ms at 48 kHz       |
| 0   |     | 0       | 1  | 1  | 2048-step update at 4 f <sub>S</sub> , 170 ms at 48 kHz       |

**Table 7-31. Treble and Bass Gain Step Size (Slew Rate)**

| D7 | D6 | D5 | D4 | D3 | D2 | D1 | D0 | FUNCTION   |
|----|----|----|----|----|----|----|----|--|
| 0  | 0  | 0  | 0  | 0  | 0  | 0  | 0  | No operation   |
| 0  | 0  | 0  | 0  | 0  | 1  | 0  | 0  | Minimum rate – Updates every 0.083 ms (every LRCLK at 48 kHz)  |
| 0  | 0  | 1  | 0  | 0  | 0  | 0  | 0  | Updates every 0.67 ms (32 LRCLKs at 48 kHz)  |
| 0  | 0  | 1  | 1  | 1  | 1  | 1  | 1  | <b>Default rate - Updates every 1.31 ms (63 LRCLKs at 48 kHz). This is the maximum constant time that can be set for all sample rates.</b> |
| 1  | 1  | 1  | 1  | 1  | 1  | 1  | 1  | Maximum rate – Updates every 5.08 ms (every 255 LRCLKs at 48 kHz)  |

## 7.27 Volume Registers (0xD1–0xD9)

Channels 1, 2, 3, 4, 5, 6, 7, and 8 are mapped into registers 0xD1, 0xD2, 0xD3, 0xD4, 0xD5, 0xD6, 0xD7, and 0xD8, respectively. The default volume for all channels is 0 dB.

Master volume is mapped into register 0xD9. The default for the master volume is mute.

Bits D31–D12 are *don't care*.

**Table 7-32. Volume Register Format**

| D31 | D30 | D29 | D28 | D27 | D26 | D25 | D24 | FUNCTION    |
|-----|-----|-----|-----|-----|-----|-----|-----|-------------|
|     |     |     |     |     |     |     |     | Unused bits |
| D23 | D22 | D21 | D20 | D19 | D18 | D17 | D16 | FUNCTION    |
|     |     |     |     |     |     |     |     | Unused bits |
| D15 | D14 | D13 | D12 | D11 | D10 | D9  | D8  | FUNCTION    |
|     |     |     |     | V11 | V10 | V9  | V8  | Volume      |
| D7  | D6  | D5  | D4  | D3  | D2  | D1  | D0  | FUNCTION    |
| V7  | V6  | V5  | V4  | V3  | V2  | V1  | V0  | Volume      |

**Table 7-33. Master and Individual Volume Controls**

| VOLUME INDEX (H) | GAIN (dB)   |
|------------------|-------------|
| 001              | 17.75       |
| 002              | 17.5        |
| 003              | 17.25       |
| 004              | 17          |
| 005              | 16.75       |
| 006              | 16.5        |
| 007              | 16.25       |
| 008              | 16          |
| 009              | 15.75       |
| 00A              | 15.5        |
| 00B              | 15.25       |
| 00C              | 15          |
| 00D              | 14.75       |
| 00E              | 14.5        |
| 00F              | 14.25       |
| 010              | 14          |
| <b>TO</b>        |             |
| 044              | 1           |
| 045              | 0.75        |
| 046              | 0.5         |
| 047              | 0.25        |
| 048              | 0           |
| 049              | -0.25       |
| 04A              | -0.5        |
| 04B              | -0.75       |
| 04C              | -1          |
| <b>TO</b>        |             |
| 1F8              | -108        |
| 1F9              | -108.25     |
| 1FA              | -108.5      |
| 1FB              | -108.75     |
| 1FC              | -109        |
| 1FD              | Mute        |
| <b>TO</b>        |             |
| <b>245</b>       | <b>Mute</b> |

## 7.28 Bass Filter Set Register (0xDA)

To use the bass and treble function, the bass and treble bypass registers (0x89–0x90) must be configured as inline (default is bypass).

**Table 7-34. Channel 8 (Subwoofer)**

| D31 | D30      | D29      | D28      | D27      | D26      | D25      | D24      | FUNCTION                 |
|-----|----------|----------|----------|----------|----------|----------|----------|--------------------------|
| 0   | 0        | 0        | 0        | 0        | 0        | 0        | 0        | No change                |
| 0   | 0        | 0        | 0        | 0        | 0        | 0        | 1        | Bass filter set 1        |
| 0   | 0        | 0        | 0        | 0        | 0        | 1        | 0        | Bass filter set 2        |
| 0   | <b>0</b> | <b>0</b> | <b>0</b> | <b>0</b> | <b>0</b> | <b>1</b> | <b>1</b> | <b>Bass filter set 3</b> |
| 0   | 0        | 0        | 0        | 0        | 1        | 0        | 0        | Bass filter set 4        |
| 0   | 0        | 0        | 0        | 0        | 1        | 0        | 1        | Bass filter set 5        |
| 0   | 0        | 0        | 0        | 0        | 1        | 1        | 0        | Reserved                 |
| 0   | 0        | 0        | 0        | 0        | 1        | 1        | 1        | Reserved                 |

**Table 7-35. Channels 6 and 5 (Right and Left Lineout in 6-Channel Configuration; Right and Left Surround in 8-Channel Configuration)**

| D23      | D22      | D21      | D20      | D19      | D18      | D17      | D16      | FUNCTION                 |
|----------|----------|----------|----------|----------|----------|----------|----------|--------------------------|
| 0        | 0        | 0        | 0        | 0        | 0        | 0        | 0        | No change                |
| 0        | 0        | 0        | 0        | 0        | 0        | 0        | 1        | Bass filter set 1        |
| 0        | 0        | 0        | 0        | 0        | 0        | 1        | 0        | Bass filter set 2        |
| <b>0</b> | <b>0</b> | <b>0</b> | <b>0</b> | <b>0</b> | <b>0</b> | <b>1</b> | <b>1</b> | <b>Bass filter set 3</b> |
| 0        | 0        | 0        | 0        | 0        | 1        | 0        | 0        | Bass filter set 4        |
| 0        | 0        | 0        | 0        | 0        | 1        | 0        | 1        | Bass filter set 5        |
| 0        | 0        | 0        | 0        | 0        | 1        | 1        | 0        | Reserved                 |
| 0        | 0        | 0        | 0        | 0        | 1        | 1        | 1        | Reserved                 |

**Table 7-36. Channels 4 and 3 (Right and Left Rear)**

| D15      | D14      | D13      | D12      | D11      | D10      | D9       | D8       | FUNCTION                 |
|----------|----------|----------|----------|----------|----------|----------|----------|--------------------------|
| 0        | 0        | 0        | 0        | 0        | 0        | 0        | 0        | No change                |
| 0        | 0        | 0        | 0        | 0        | 0        | 0        | 1        | Bass filter set 1        |
| 0        | 0        | 0        | 0        | 0        | 0        | 1        | 0        | Bass filter set 2        |
| <b>0</b> | <b>0</b> | <b>0</b> | <b>0</b> | <b>0</b> | <b>0</b> | <b>1</b> | <b>1</b> | <b>Bass filter set 3</b> |
| 0        | 0        | 0        | 0        | 0        | 1        | 0        | 0        | Bass filter set 4        |
| 0        | 0        | 0        | 0        | 0        | 1        | 0        | 1        | Bass filter set 5        |
| 0        | 0        | 0        | 0        | 0        | 1        | 1        | 0        | Reserved                 |
| 0        | 0        | 0        | 0        | 0        | 1        | 1        | 1        | Reserved                 |

**Table 7-37. Channels 7, 2, and 1 (Center, Right Front, and Left Front)**

| D7       | D6       | D5       | D4       | D3       | D2       | D1       | D0       | FUNCTION                 |
|----------|----------|----------|----------|----------|----------|----------|----------|--------------------------|
| 0        | 0        | 0        | 0        | 0        | 0        | 0        | 0        | No change                |
| 0        | 0        | 0        | 0        | 0        | 0        | 0        | 1        | Bass filter set 1        |
| 0        | 0        | 0        | 0        | 0        | 0        | 1        | 0        | Bass filter set 2        |
| <b>0</b> | <b>0</b> | <b>0</b> | <b>0</b> | <b>0</b> | <b>0</b> | <b>1</b> | <b>1</b> | <b>Bass filter set 3</b> |
| 0        | 0        | 0        | 0        | 0        | 1        | 0        | 0        | Bass filter set 4        |
| 0        | 0        | 0        | 0        | 0        | 1        | 0        | 1        | Bass filter set 5        |
| 0        | 0        | 0        | 0        | 0        | 1        | 1        | 0        | Reserved                 |
| 0        | 0        | 0        | 0        | 0        | 1        | 1        | 1        | Reserved                 |

## 7.29 Bass Filter Index Register (0xDB)

Index values above 0x24 are invalid. To use the bass and treble function, the bass and treble bypass registers (0x89–0x90) must be configured as inline (default is bypass).

**Table 7-38. Bass Filter Index Register Format**

| I <sup>2</sup> C SUBADDRESS | TOTAL BYTES | REGISTER NAME           | DESCRIPTION OF CONTENTS   | DEFAULT STATE          |
|-----------------------------|-------------|-------------------------|---|------------------------|
| 0xDB                        | 4           | Bass filter index (BFI) | Ch8_BFI[31:24], Ch65_BFI[23:16], Ch43_BFI[15:8], Ch721_BFI[7:0] | 0x12, 0x12, 0x12, 0x12 |

**Table 7-39. Bass Filter Indexes**

| BASS INDEX VALUE | ADJUSTMENT (dB) | BASS INDEX VALUE | ADJUSTMENT (dB) |
|------------------|-----------------|------------------|-----------------|
| 0x00             | 18              | 0x13             | –1              |
| 0x01             | 17              | 0x14             | –2              |
| 0x02             | 16              | 0x15             | –3              |
| 0x03             | 15              | 0x16             | –4              |
| 0x04             | 14              | 0x17             | –5              |
| 0x05             | 13              | 0x18             | –6              |
| 0x06             | 12              | 0x19             | –7              |
| 0x07             | 11              | 0x1A             | –8              |
| 0x08             | 10              | 0x1B             | –9              |
| 0x09             | 9               | 0x1C             | –10             |
| 0x0A             | 8               | 0x1D             | –11             |
| 0x0B             | 7               | 0x1E             | –12             |
| 0x0C             | 6               | 0x1F             | –13             |
| 0x0D             | 5               | 0x20             | –14             |
| 0x0E             | 4               | 0x21             | –15             |
| 0x0F             | 3               | 0x22             | –16             |
| 0x10             | 2               | 0x23             | –17             |
| 0x11             | 1               | 0x24             | –18             |
| <b>0x12</b>      | <b>0</b>        |                  |                 |



### 7.30 Treble Filter Set Register (0xDC)

Bits D31–D27 are *don't care*. To use the bass and treble function, the bass and treble bypass registers (0x89 - 0x90) must be configured as inline (enabled).

**Table 7-40. Channel 8 (Subwoofer)**

| D31      | D30      | D29      | D28      | D27      | D26      | D25      | D24      | FUNCTION                   |
|----------|----------|----------|----------|----------|----------|----------|----------|----------------------------|
| 0        | 0        | 0        | 0        | 0        | 0        | 0        | 0        | No change                  |
| 0        | 0        | 0        | 0        | 0        | 0        | 0        | 1        | Treble filter set 1        |
| 0        | 0        | 0        | 0        | 0        | 0        | 1        | 0        | Treble filter set 2        |
| <b>0</b> | <b>0</b> | <b>0</b> | <b>0</b> | <b>0</b> | <b>0</b> | <b>1</b> | <b>1</b> | <b>Treble filter set 3</b> |
| 0        | 0        | 0        | 0        | 0        | 1        | 0        | 0        | Treble filter set 4        |
| 0        | 0        | 0        | 0        | 0        | 1        | 0        | 1        | Treble filter set 5        |
| 0        | 0        | 0        | 0        | 0        | 1        | 1        | 0        | Reserved                   |
| 0        | 0        | 0        | 0        | 0        | 1        | 1        | 1        | Reserved                   |

Bits D23–D19 are *don't care*.

**Table 7-41. Channels 6 and 5 (Right and Left Lineout in 6-Channel Configuration; Right and Left Surround in 8-Channel Configuration)**

| D23      | D22      | D21      | D20      | D19      | D18      | D17      | D16      | FUNCTION                   |
|----------|----------|----------|----------|----------|----------|----------|----------|----------------------------|
| 0        | 0        | 0        | 0        | 0        | 0        | 0        | 0        | No change                  |
| 0        | 0        | 0        | 0        | 0        | 0        | 0        | 1        | Treble filter set 1        |
| 0        | 0        | 0        | 0        | 0        | 0        | 1        | 0        | Treble filter set 2        |
| <b>0</b> | <b>0</b> | <b>0</b> | <b>0</b> | <b>0</b> | <b>0</b> | <b>1</b> | <b>1</b> | <b>Treble filter set 3</b> |
| 0        | 0        | 0        | 0        | 0        | 1        | 0        | 0        | Treble filter set 4        |
| 0        | 0        | 0        | 0        | 0        | 1        | 0        | 1        | Treble filter set 5        |
| 0        | 0        | 0        | 0        | 0        | 1        | 1        | 0        | Reserved                   |
| 0        | 0        | 0        | 0        | 0        | 1        | 1        | 1        | Reserved                   |

Bits D15–D11 are *don't care*.

**Table 7-42. Channels 4 and 3 (Right and Left Rear)**

| D15      | D14      | D13      | D12      | D11      | D10      | D9       | D8       | FUNCTION                   |
|----------|----------|----------|----------|----------|----------|----------|----------|----------------------------|
| 0        | 0        | 0        | 0        | 0        | 0        | 0        | 0        | No change                  |
| 0        | 0        | 0        | 0        | 0        | 0        | 0        | 1        | Treble filter set 1        |
| 0        | 0        | 0        | 0        | 0        | 0        | 1        | 0        | Treble filter set 2        |
| <b>0</b> | <b>0</b> | <b>0</b> | <b>0</b> | <b>0</b> | <b>0</b> | <b>1</b> | <b>1</b> | <b>Treble filter set 3</b> |
| 0        | 0        | 0        | 0        | 0        | 1        | 0        | 0        | Treble filter set 4        |
| 0        | 0        | 0        | 0        | 0        | 1        | 0        | 1        | Treble filter set 5        |
| 0        | 0        | 0        | 0        | 0        | 1        | 1        | 0        | Reserved                   |
| 0        | 0        | 0        | 0        | 0        | 1        | 1        | 1        | Reserved                   |

Bits D7–D3 are *don't care*.

**Table 7-43. Channels 7, 2, and 1 (Center, Right Front, and Left Front)**

| D7       | D6       | D5       | D4       | D3       | D2       | D1       | D0       | FUNCTION                   |
|----------|----------|----------|----------|----------|----------|----------|----------|----------------------------|
| 0        | 0        | 0        | 0        | 0        | 0        | 0        | 0        | No change                  |
| 0        | 0        | 0        | 0        | 0        | 0        | 0        | 1        | Treble filter set 1        |
| 0        | 0        | 0        | 0        | 0        | 0        | 1        | 0        | Treble filter set 2        |
| <b>0</b> | <b>0</b> | <b>0</b> | <b>0</b> | <b>0</b> | <b>0</b> | <b>1</b> | <b>1</b> | <b>Treble filter set 3</b> |
| 0        | 0        | 0        | 0        | 0        | 1        | 0        | 0        | Treble filter set 4        |
| 0        | 0        | 0        | 0        | 0        | 1        | 0        | 1        | Treble filter set 5        |
| 0        | 0        | 0        | 0        | 0        | 1        | 1        | 0        | Reserved                   |
| 0        | 0        | 0        | 0        | 0        | 1        | 1        | 1        | Reserved                   |

### 7.31 Treble Filter Index (0xDD)

Index values above 0x24 are invalid. To use the bass and treble function, the bass and treble bypass registers (0x89 - 0x90) must be configured as inline (enabled).

**Table 7-44. Treble Filter Index Register Format**

| I <sup>2</sup> C SUBADDRESS | TOTAL BYTES | REGISTER NAME             | DESCRIPTION OF CONTENTS   | DEFAULT STATE          |
|-----------------------------|-------------|---------------------------|---|------------------------|
| 0xDD                        | 4           | Treble filter index (TFI) | Ch8_TFI[31:24], Ch65_TFI[23:16], Ch43_TFI[15:8], Ch721_TFI[7:0] | 0x12, 0x12, 0x12, 0x12 |

**Table 7-45. Treble Filter Indexes**

| TREBLE INDEX VALUE | ADJUSTMENT (dB) | TREBLE INDEX VALUE | ADJUSTMENT (dB) |
|--------------------|-----------------|--------------------|-----------------|
| 0x00               | 18              | 0x13               | -1              |
| 0x01               | 17              | 0x14               | -2              |
| 0x02               | 16              | 0x15               | -3              |
| 0x03               | 15              | 0x16               | -4              |
| 0x04               | 14              | 0x17               | -5              |
| 0x05               | 13              | 0x18               | -6              |
| 0x06               | 12              | 0x19               | -7              |
| 0x07               | 11              | 0x1A               | -8              |
| 0x08               | 10              | 0x1B               | -9              |
| 0x09               | 9               | 0x1C               | -10             |
| 0x0A               | 8               | 0x1D               | -11             |
| 0x0B               | 7               | 0x1E               | -12             |
| 0x0C               | 6               | 0x1F               | -13             |
| 0x0D               | 5               | 0x20               | -14             |
| 0x0E               | 4               | 0x21               | -15             |
| 0x0F               | 3               | 0x22               | -16             |
| 0x10               | 2               | 0x23               | -17             |
| 0x11               | 1               | 0x24               | -18             |
| <b>0x12</b>        | <b>0</b>        |                    |                 |

### 7.32 AM Mode Register (0xDE)

Bits D31–D21 are *don't care*.

**Table 7-46. AM Mode Register Format**

| D31 | D30 | D29 | D28 | D27 | D26 | D25 | D24 | FUNCTION                   |
|-----|-----|-----|-----|-----|-----|-----|-----|----------------------------|
|     |     |     |     |     |     |     |     | Unused bits                |
| D23 | D22 | D21 | D20 | D19 | D18 | D17 | D16 | FUNCTION                   |
|     |     |     | 0   | –   | –   | –   | –   | AM mode disabled           |
|     |     |     | 1   | –   | –   | –   | –   | AM mode enabled            |
|     |     |     | –   | 0   | 0   | –   | –   | Select sequence 1          |
|     |     |     | –   | 0   | 1   | –   | –   | Select sequence 2          |
|     |     |     | –   | 1   | 0   | –   | –   | Select sequence 3          |
|     |     |     | –   | 1   | 1   | –   | –   | Select sequence 4          |
|     |     |     | –   | –   | –   | 0   | –   | IF frequency = 455 kHz     |
|     |     |     | –   | –   | –   | 1   | –   | IF frequency = 262.5 kHz   |
|     |     |     | –   | –   | –   | –   | 0   | Use BCD-tuned frequency    |
|     |     |     | –   | –   | –   | –   | 1   | Use binary-tuned frequency |

**Table 7-47. AM Tuned Frequency Register in BCD Mode (Lower 2 Bytes of 0xDE)**

| D15 | D14 | D13 | D12 | D11 | D10 | D9 | D8 | FUNCTION                  |
|-----|-----|-----|-----|-----|-----|----|----|---------------------------|
| 0   | 0   | 0   | B0  | –   | –   | –  | –  | BCD frequency (1000s kHz) |
| –   | –   | –   | –   | B3  | B2  | B1 | B0 | BCD frequency (100s kHz)  |
| 0   | 0   | 0   | 0   | 0   | 0   | 0  | 0  | Default value             |
| D7  | D6  | D5  | D4  | D3  | D2  | D1 | D0 | FUNCTION                  |
| B3  | B2  | B1  | B0  | –   | –   | –  | –  | BCD frequency (10s kHz)   |
| –   | –   | –   | –   | B3  | B2  | B1 | B0 | BCD frequency (1s kHz)    |
| 0   | 0   | 0   | 0   | 0   | 0   | 0  | 0  | Default value             |

**Table 7-48. AM Tuned Frequency Register in Binary Mode (Lower 2 Bytes of 0xDE)**

| D15 | D14 | D13 | D12 | D11 | D10 | D9 | D8 | FUNCTION                        |
|-----|-----|-----|-----|-----|-----|----|----|---------------------------------|
| 0   | 0   | 0   | 0   | 0   | B10 | B9 | B8 | Binary frequency (upper 3 bits) |
| 0   | 0   | 0   | 0   | 0   | 0   | 0  | 0  | Default value                   |
| D7  | D6  | D5  | D4  | D3  | D2  | D1 | D0 | FUNCTION                        |
| B7  | B6  | B5  | B4  | B3  | B2  | B1 | B0 | Binary frequency (lower 8 bits) |
| 0   | 0   | 0   | 0   | 0   | 0   | 0  | 0  | Default value                   |

### 7.33 PSVC Range Register (0xDF)

Bits D31–D2 are zero.

Table 7-49. PSVC Range Register Format

| D31–D2   | D1       | D0       | FUNCTION                               |
|----------|----------|----------|--|
| 0        | 0        | 0        | 12.04-dB control range for PSVC        |
| 0        | 0        | 1        | 18.06-dB control range for PSVC        |
| <b>0</b> | <b>1</b> | <b>0</b> | <b>24.08-dB control range for PSVC</b> |
| 0        | 1        | 1        | Ignore – retain last value             |

### 7.34 General Control Register (0xE0)

Bits D31–D4 are zero. Bit D0 is *don't care*.

Table 7-50. General Control Register Format

| D31–D4   | D3       | D2       | D1       | D0 | FUNCTION   |
|----------|----------|----------|----------|----|--|
| <b>0</b> | –        | –        | <b>0</b> |    | <b>8-channel configuration</b>   |
| 0        | –        | –        | 1        |    | 6-channel configuration  |
| <b>0</b> | –        | <b>0</b> | –        |    | <b>Power-supply volume control disabled</b>  |
| 0        | –        | 1        | –        |    | Power-supply volume control enabled  |
| <b>0</b> | <b>0</b> | –        | –        |    | <b>Subwoofer part of PSVC. This bit must always be 0. (D3 is a write-only bit)</b> |

### 7.35 Incremental Multiple-Byte Write Append Register (0xFE)

This is a special register used to append data to a previously opened register. See *Multiple-Byte Write*, [Section 5.4](#), for programming details.



## **8 TAS5508B Example Application Schematic**

The following page contains an example application schematic for the TAS5508B.

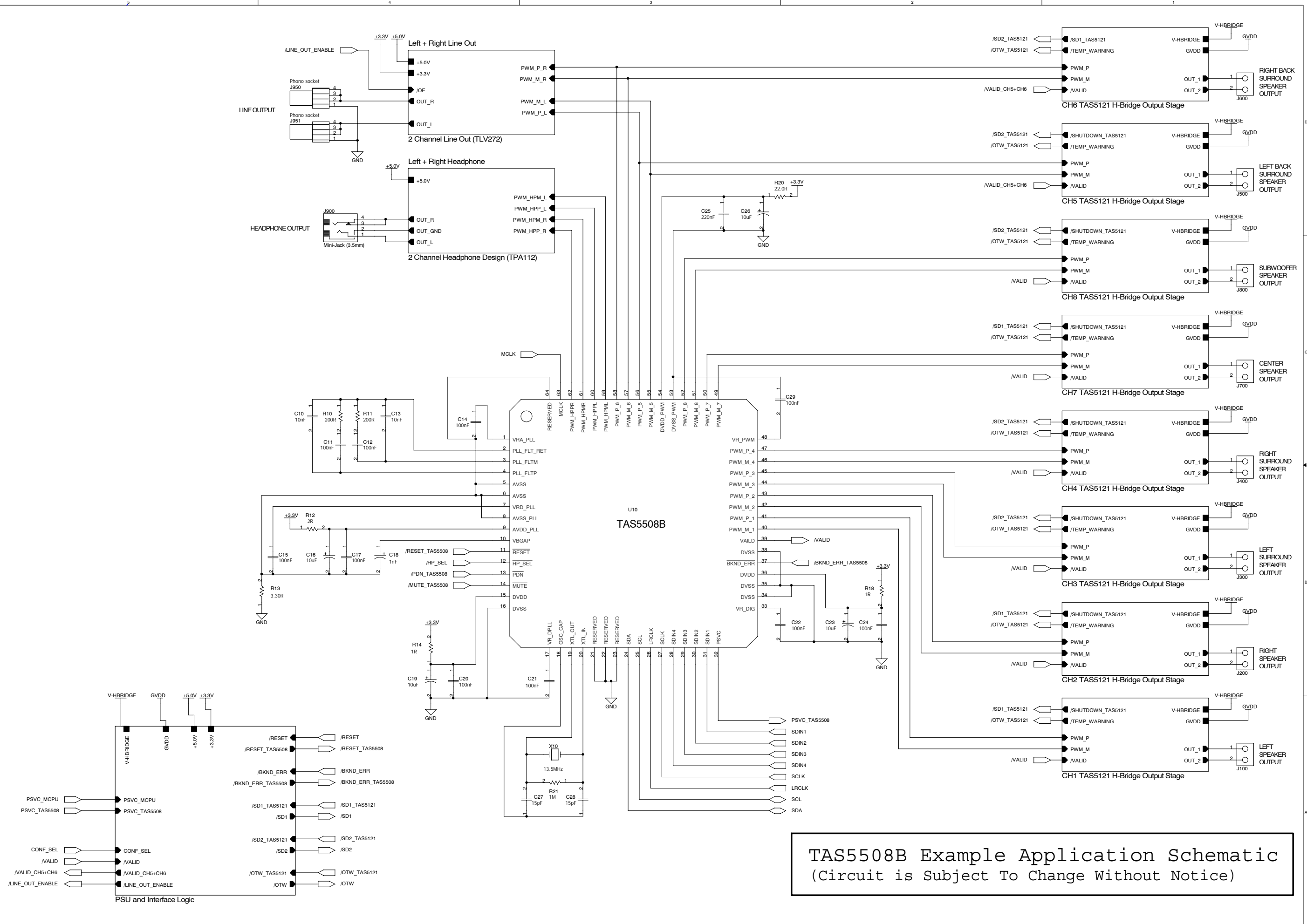

TAS5508B Example Application Schematic  
(Circuit is Subject To Change Without Notice)

**PACKAGING INFORMATION**

| Orderable Device | Status <sup>(1)</sup> | Package Type | Package Drawing | Pins | Package Qty | Eco Plan <sup>(2)</sup> | Lead/Ball Finish | MSL Peak Temp <sup>(3)</sup> |
|------------------|-----------------------|--------------|-----------------|------|-------------|-------------------------|------------------|------------------------------|
| TAS5508BPAG      | ACTIVE                | TQFP         | PAG             | 64   | 160         | Green (RoHS & no Sb/Br) | CU NIPDAU        | Level-4-260C-72 HR           |
| TAS5508BPAGG4    | ACTIVE                | TQFP         | PAG             | 64   | 160         | Green (RoHS & no Sb/Br) | CU NIPDAU        | Level-4-260C-72 HR           |
| TAS5508BPAGR     | ACTIVE                | TQFP         | PAG             | 64   | 1500        | Green (RoHS & no Sb/Br) | CU NIPDAU        | Level-4-260C-72 HR           |
| TAS5508BPAGRG4   | ACTIVE                | TQFP         | PAG             | 64   | 1500        | Green (RoHS & no Sb/Br) | CU NIPDAU        | Level-4-260C-72 HR           |

<sup>(1)</sup> The marketing status values are defined as follows:

**ACTIVE:** Product device recommended for new designs.

**LIFEBUY:** TI has announced that the device will be discontinued, and a lifetime-buy period is in effect.

**NRND:** Not recommended for new designs. Device is in production to support existing customers, but TI does not recommend using this part in a new design.

**PREVIEW:** Device has been announced but is not in production. Samples may or may not be available.

**OBSOLETE:** TI has discontinued the production of the device.

<sup>(2)</sup> Eco Plan - The planned eco-friendly classification: Pb-Free (RoHS), Pb-Free (RoHS Exempt), or Green (RoHS & no Sb/Br) - please check <http://www.ti.com/productcontent> for the latest availability information and additional product content details.

**TBD:** The Pb-Free/Green conversion plan has not been defined.

**Pb-Free (RoHS):** TI's terms "Lead-Free" or "Pb-Free" mean semiconductor products that are compatible with the current RoHS requirements for all 6 substances, including the requirement that lead not exceed 0.1% by weight in homogeneous materials. Where designed to be soldered at high temperatures, TI Pb-Free products are suitable for use in specified lead-free processes.

**Pb-Free (RoHS Exempt):** This component has a RoHS exemption for either 1) lead-based flip-chip solder bumps used between the die and package, or 2) lead-based die adhesive used between the die and leadframe. The component is otherwise considered Pb-Free (RoHS compatible) as defined above.

**Green (RoHS & no Sb/Br):** TI defines "Green" to mean Pb-Free (RoHS compatible), and free of Bromine (Br) and Antimony (Sb) based flame retardants (Br or Sb do not exceed 0.1% by weight in homogeneous material)

<sup>(3)</sup> MSL, Peak Temp. -- The Moisture Sensitivity Level rating according to the JEDEC industry standard classifications, and peak solder temperature.

**Important Information and Disclaimer:**The information provided on this page represents TI's knowledge and belief as of the date that it is provided. TI bases its knowledge and belief on information provided by third parties, and makes no representation or warranty as to the accuracy of such information. Efforts are underway to better integrate information from third parties. TI has taken and continues to take reasonable steps to provide representative and accurate information but may not have conducted destructive testing or chemical analysis on incoming materials and chemicals. TI and TI suppliers consider certain information to be proprietary, and thus CAS numbers and other limited information may not be available for release.

In no event shall TI's liability arising out of such information exceed the total purchase price of the TI part(s) at issue in this document sold by TI to Customer on an annual basis.



PAG (S-PQFP-G64)

PLASTIC QUAD FLATPACK



- NOTES: A. All linear dimensions are in millimeters.  
 B. This drawing is subject to change without notice.  
 C. Falls within JEDEC MS-026

## IMPORTANT NOTICE

Texas Instruments Incorporated and its subsidiaries (TI) reserve the right to make corrections, modifications, enhancements, improvements, and other changes to its products and services at any time and to discontinue any product or service without notice. Customers should obtain the latest relevant information before placing orders and should verify that such information is current and complete. All products are sold subject to TI's terms and conditions of sale supplied at the time of order acknowledgment.

TI warrants performance of its hardware products to the specifications applicable at the time of sale in accordance with TI's standard warranty. Testing and other quality control techniques are used to the extent TI deems necessary to support this warranty. Except where mandated by government requirements, testing of all parameters of each product is not necessarily performed.

TI assumes no liability for applications assistance or customer product design. Customers are responsible for their products and applications using TI components. To minimize the risks associated with customer products and applications, customers should provide adequate design and operating safeguards.

TI does not warrant or represent that any license, either express or implied, is granted under any TI patent right, copyright, mask work right, or other TI intellectual property right relating to any combination, machine, or process in which TI products or services are used. Information published by TI regarding third-party products or services does not constitute a license from TI to use such products or services or a warranty or endorsement thereof. Use of such information may require a license from a third party under the patents or other intellectual property of the third party, or a license from TI under the patents or other intellectual property of TI.

Reproduction of information in TI data books or data sheets is permissible only if reproduction is without alteration and is accompanied by all associated warranties, conditions, limitations, and notices. Reproduction of this information with alteration is an unfair and deceptive business practice. TI is not responsible or liable for such altered documentation.

Resale of TI products or services with statements different from or beyond the parameters stated by TI for that product or service voids all express and any implied warranties for the associated TI product or service and is an unfair and deceptive business practice. TI is not responsible or liable for any such statements.

Following are URLs where you can obtain information on other Texas Instruments products and application solutions:

| <b>Products</b>    |  | <b>Applications</b> |  |
|--------------------|--|---------------------|--|
| Amplifiers         | <a href="http://amplifier.ti.com">amplifier.ti.com</a>             | Audio               | <a href="http://www.ti.com/audio">www.ti.com/audio</a>                   |
| Data Converters    | <a href="http://dataconverter.ti.com">dataconverter.ti.com</a>     | Automotive          | <a href="http://www.ti.com/automotive">www.ti.com/automotive</a>         |
| DSP                | <a href="http://dsp.ti.com">dsp.ti.com</a>                         | Broadband           | <a href="http://www.ti.com/broadband">www.ti.com/broadband</a>           |
| Interface          | <a href="http://interface.ti.com">interface.ti.com</a>             | Digital Control     | <a href="http://www.ti.com/digitalcontrol">www.ti.com/digitalcontrol</a> |
| Logic              | <a href="http://logic.ti.com">logic.ti.com</a>                     | Military            | <a href="http://www.ti.com/military">www.ti.com/military</a>             |
| Power Mgmt         | <a href="http://power.ti.com">power.ti.com</a>                     | Optical Networking  | <a href="http://www.ti.com/opticalnetwork">www.ti.com/opticalnetwork</a> |
| Microcontrollers   | <a href="http://microcontroller.ti.com">microcontroller.ti.com</a> | Security            | <a href="http://www.ti.com/security">www.ti.com/security</a>             |
| Low Power Wireless | <a href="http://www.ti.com/lpw">www.ti.com/lpw</a>                 | Telephony           | <a href="http://www.ti.com/telephony">www.ti.com/telephony</a>           |
|                    |  | Video & Imaging     | <a href="http://www.ti.com/video">www.ti.com/video</a>                   |
|                    |  | Wireless            | <a href="http://www.ti.com/wireless">www.ti.com/wireless</a>             |

Mailing Address: Texas Instruments  
Post Office Box 655303 Dallas, Texas 75265